



M.F. MARTINS, S.A.
FERRAMENTAS





Sede:

Travessa do Barroco, nº308 - Apartado 140 * 4416-901 Pedroso - V. N. Gaia - Portugal
Telefs: 22 787 72 10 - Fax: 22 783 44 75 * geral@mfmartins.pt - www.mfmartins.pt



Armazém / Showroom:

Rua 5 de Outubro nº4845 * 4430-000 Avintes - V. N. Gaia

A Empresa foi fundada em 11 de Junho de 1980 pelo atual diretor Manuel Martins. Pautando o seu caminho pelo rigor e profissionalismo, continua a trabalhar com a finalidade de prestar cada vez mais, um melhor e rápido serviço aos seus clientes. Neste momento com cerca de 2700m² de área comercial e administrativa, a Empresa está dotada de infra-estruturas modernas e capazes de responder às exigências cada vez maiores do mercado.



A excelência não é um feito mas sim um hábito





ENTREGAS IMEDIATAS

- *Pedidos servidos em 12/24 horas*
- *60.000 referências em stock*



ATENDIMENTO

- *Atendimento telefónico personalizado*
- *Directamente ao seu gestor de conta*
- *Ajuda na selecção da ferramenta adequada*



SERVIÇO ON LINE

- *Compra*
- *Consulta de stocks*
- *Catálogos*
- *Tesouraria*



FORMAÇÃO A CLIENTES

- *Reuniões de formação diversas*
- *Direccionadas às necessidades dos clientes*

ADMINISTRAÇÃO



DEPARTAMENTO ADMINISTRATIVO



DEPARTAMENTO COMERCIAL

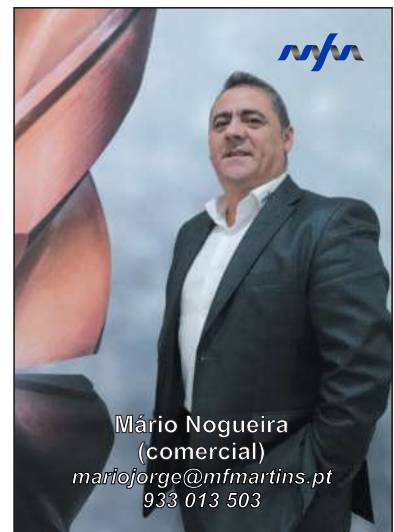
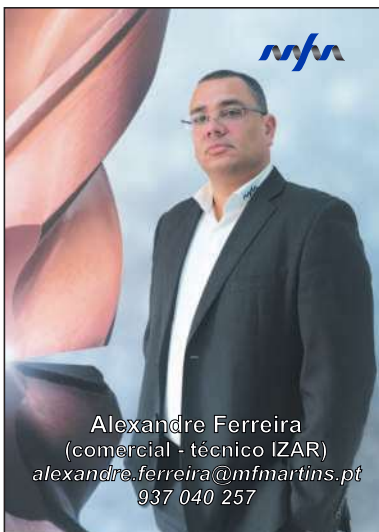

GESTORES DE CLIENTES



RECECIONISTA E LOGÍSTICA ARMAZÉM





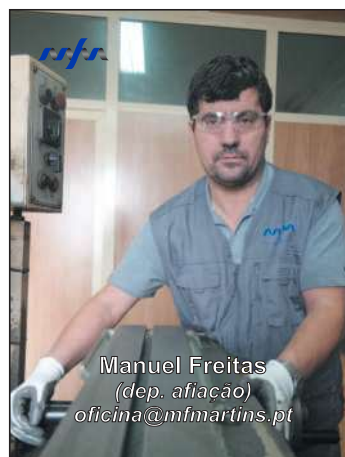























DEPARTAMENTO OFICINA

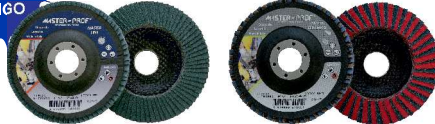

<i>Brocas cilíndricas rectificadas HSS</i>		010 e 011
<i>Jogos, malas e expositores de brocas cil. rect. HSS</i>		012
<i>Brocas cilíndricas rectificadas HSS-CO 8%</i>		013
<i>Jogos, malas e expositores de brocas cil. HSS-CO 8%</i>		014
<i>Brocas cilíndricas rectificadas HSS-G Speedmaster</i>		015
<i>Brocas cilíndricas rebaixasadas HSS e HSS-CO</i>		016
<i>Brocas cilíndricas rectificadas HSS extra curta</i>		017
<i>Brocas cilíndricas rectificadas longas em HSS</i>		018
<i>Brocas cilíndricas HSS-CO p/Inox e ponta metal duro</i>		019
<i>Brocas cilíndricas HSS para alumínio e latão</i>		020
<i>Brocas helicoidais cabo cónico HSS</i>		021
<i>Expositores de brocas helicoidais cabo cónico HSS</i>		022
<i>Brocas helicoidais cabo cónico c/ponta metal duro</i>		023
<i>Brocas helicoidais cabo cónico com refrigeração HSS</i>		024

Índice de artigos por ordem alfabética

Brocas para martelos SDS "S4" super profissional		025
Brocas para martelos "4x4" super profissional		026
Brocas para martelos SDS MAX 4 cortes Premium	 NOVO ARTIGO	027
Brocas cil.p/pedra "Standard" qualidade extra e Longa		028
Brocas universais "Fura Tudo"		029
Brocas universais "Fura Tudo" de alto rendimento		030
Brocas "Master Granito"		031
Brocas "Extreme" e brocas para vidro		032
Brocas de centrar T/A HSS		033
Brocas para pontos de soldadura		034
Brocas diamantadas para grês porcelânico		035
Brocas combinadas hexagonais 1/4		036
Brocas forma Lewis para madeira		037
Brocas puas planas para madeira		038

<i>Brocas com ponta guia e Forstner para madeira</i>		039
<i>Bits, jogos e expositor</i>		040 a 056
<i>Buchas e acessórios</i>		057 a 060
<i>Buris e lâminas</i>		061 a 063
<i>Discos abrasivos</i>		064 a 065
<i>Lamelas</i>		066
<i>Discos de diamante, coroas de rebaixar e mós</i>		067 a 070
<i>Escareadores</i>		071 a 073
<i>Fresas escalonadas</i>		074
<i>Fresas frontais</i>		075 a 085
<i>Fresas para máquinas com base electromagnética</i>		086 a 091
<i>Fresas perfuradoras</i>		092 a 101
<i>Fresas rotativas</i>		102 a 104
<i>Fresas para martelo com dentes em metal duro</i>		105 a 106

Machos, caçonetes, desandadores, jogos e Kits



107 a 131

Machos, jogos e acessórios K-Coil



132 a 138

Mandris



139

Óleo



140 a 141

Pastilhas e ferros



142 a 150

Pinças de precisão, jogos e cones para pinças



151 a 154

Saca bocados



155 a 156

Serras craneanas HSS e HSS-CO



157 a 160

Serras circulares



161 a 166

Serras de fita



167 a 169

Expositores e módulos













170 a 175

Ficha técnica

176 a 185

Índice de artigos por ordem alfabética de marcas representadas

 <i>Material de precisão</i>	<i>Tabela / Preçário em separado</i>	186
 <i>Material de precisão</i>	 <i>Tabela / Preçário em separado</i>	187
 <i>Ferramentas de corte</i>	<i>Tabela / Preçário em separado</i>	188 a 189
 <i>Serras circulares</i>		190 a 193
 <i>Limas</i>		194 a 201
 <i>Máquinas de serra de fita</i>	<i>Tabela / Preçário em separado</i>	202 a 207
 <i>Abrasivos</i>		208 a 213
 <i>Buchas e acessórios</i>	<i>Tabela / Preçário em separado</i>	214 a 223
 <i>Serras de fita</i>		224 a 254
<i>Condições gerais de venda</i>		255

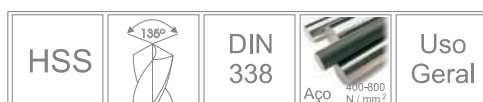

Código	∅	l mm	L mm	PCS	€	Código	∅	l mm	L mm	PCS	€
MHSS01	1,00	12	34	10	0,19	MHSS17	5,00	52	86	10	0,48
MHSD01	1,10	14	36	10	0,41	MHSD33	5,10	52	86	10	0,93
MHSD02	1,20	16	38	10	0,41	MHSD34	5,20	52	86	10	0,93
MHSS02	1,25	16	38	10	0,19	MHSS18	5,25	52	86	10	0,59
MHSD03	1,30	16	38	10	0,41	MHSD35	5,30	52	86	10	0,93
MHSD04	1,40	18	40	10	0,41	MHSD36	5,40	57	93	10	0,93
MHSS03	1,50	18	40	10	0,19	MHSS19	5,50	57	93	10	0,59
MHSD05	1,60	20	43	10	0,42	MHSD37	5,60	57	93	10	1,03
MHSD06	1,70	20	43	10	0,42	MHSD38	5,70	57	93	10	1,03
MHSS04	1,75	22	46	10	0,19	MHSS20	5,75	57	93	10	0,67
MHSD07	1,80	22	46	10	0,42	MHSD39	5,80	57	93	10	1,03
MHSD08	1,90	22	46	10	0,42	MHSD40	5,90	57	93	10	1,03
MHSS05	2,00	24	49	10	0,19	MHSS21	6,00	57	93	10	0,67
MHSD09	2,10	24	49	10	0,45	MHSD41	6,10	63	101	10	1,16
MHSD10	2,20	27	53	10	0,45	MHSD42	6,20	63	101	10	1,16
MHSS06	2,25	27	53	10	0,19	MHSS22	6,25	63	101	10	0,79
MHSD11	2,30	27	53	10	0,47	MHSD43	6,30	63	101	10	1,16
MHSD12	2,40	30	57	10	0,47	MHSD44	6,40	63	101	10	1,16
MHSS07	2,50	30	57	10	0,19	MHSS23	6,50	63	101	10	0,79
MHSD13	2,60	30	57	10	0,47	MHSD45	6,60	63	101	10	1,39
MHSD14	2,70	33	61	10	0,47	MHSD46	6,70	63	101	10	1,39
MHSS08	2,75	33	61	10	0,23	MHSS24	6,75	69	109	10	0,95
MHSD15	2,80	33	61	10	0,47	MHSD47	6,80	69	109	10	1,39
MHSD16	2,90	33	61	10	0,47	MHSD48	6,90	69	109	10	1,39
MHSS09	3,00	33	61	10	0,23	MHSS25	7,00	69	109	10	0,95
MHSD17	3,10	36	65	10	0,58	MHSD49	7,10	69	109	5	1,82
MHSD18	3,20	36	65	10	0,58	MHSD50	7,20	69	109	5	1,82
MHSS10	3,25	36	65	10	0,26	MHSS26	7,25	69	109	10	1,06
MHSD19	3,30	36	65	10	0,58	MHSD51	7,30	69	109	5	1,82
MHSD20	3,40	39	70	10	0,58	MHSD52	7,40	69	109	5	1,82
MHSS11	3,50	39	70	10	0,26	MHSS27	7,50	69	109	10	1,06
MHSD21	3,60	39	70	10	0,64	MHSD53	7,60	75	117	5	1,88
MHSD22	3,70	39	70	10	0,64	MHSD54	7,70	75	117	5	1,88
MHSS12	3,75	39	70	10	0,33	MHSS28	7,75	75	117	5	1,24
MHSD23	3,80	43	75	10	0,64	MHSD55	7,80	75	117	5	1,88
MHSD24	3,90	43	75	10	0,64	MHSD56	7,90	75	117	5	1,88
MHSS13	4,00	43	75	10	0,33	MHSS29	8,00	75	117	5	1,24
MHSD25	4,10	43	75	10	0,68	MHSD57	8,10	75	117	5	2,19
MHSD26	4,20	43	75	10	0,68	MHSD58	8,20	75	117	5	2,19
MHSS14	4,25	43	75	10	0,40	MHSS30	8,25	75	117	5	1,33
MHSD27	4,30	47	80	10	0,68	MHSD59	8,30	75	117	5	2,19
MHSD28	4,40	47	80	10	0,68	MHSD60	8,40	75	117	5	2,19
MHSS15	4,50	47	80	10	0,40	MHSS31	8,50	75	117	5	1,33
MHSD29	4,60	47	80	10	0,81	MHSD61	8,60	81	125	5	2,37
MHSD30	4,70	47	80	10	0,81	MHSD62	8,70	81	125	5	2,37
MHSS16	4,75	47	80	10	0,48	MHSS32	8,75	81	125	5	1,58
MHSD31	4,80	52	86	10	0,81	MHSD63	8,80	81	125	5	2,37
MHSD32	4,90	52	86	10	0,81	MHSD64	8,90	81	125	5	2,37



Código	∅	l mm	L mm	PCS	€	Código	∅	l mm	L mm	PCS	€
MHSS33	9,00	81	125	5	1,80	MHSS53	14,00	108	160	5	5,17
MHSD65	9,10	81	125	5	2,70	MHSS54	14,25	114	169	5	5,17
MHSD66	9,20	81	125	5	2,70	MHSS55	14,50	114	169	5	5,17
MHSS34	9,25	81	125	5	1,80	MHSS56	14,75	114	169	5	5,44
MHSD67	9,30	81	125	5	2,70	MHSS57	15,00	114	169	5	5,44
MHSD68	9,40	81	125	5	2,70	MHSS58	15,25	120	178	5	5,68
MHSS35	9,50	81	125	5	1,80	MHSS59	15,50	120	178	5	5,68
MHSD69	9,60	87	133	5	3,06	MHSS60	15,75	120	178	5	5,92
MHSD70	9,70	87	133	5	3,06	MHSS61	16,00	120	178	5	5,92
MHSS36	9,75	87	133	5	2,08	MHSS62	16,25	125	184	5	6,61
MHSD71	9,80	87	133	5	3,06	MHSS63	16,50	125	184	5	6,61
MHSD72	9,90	87	133	5	3,06	MHSS64	16,75	125	184	5	6,61
MHSS37	10,00	87	133	5	2,08	MHSS65	17,00	125	184	5	6,61
MHSS38	10,25	87	133	5	2,22	MHSS66	17,25	130	191	5	7,01
MHSS39	10,50	87	133	5	2,22	MHSS67	17,50	130	191	5	7,01
MHSS40	10,75	94	142	5	2,58	MHSS68	17,75	130	191	5	7,30
MHSS41	11,00	94	142	5	2,58	MHSS69	18,00	130	191	5	7,30
MHSS42	11,25	94	142	5	2,82	MHSS70	18,25	135	198	5	8,12
MHSS43	11,50	94	142	5	2,82	MHSS71	18,50	135	198	5	8,12
MHSS44	11,75	94	142	5	3,23	MHSS72	18,75	135	198	5	8,72
MHSS45	12,00	101	151	5	3,23	MHSS73	19,00	135	198	5	8,72
MHSS46	12,25	101	151	5	3,53	MHSS74	19,25	140	205	5	9,56
MHSS47	12,50	101	151	5	3,53	MHSS75	19,50	140	205	5	9,56
MHSS48	12,75	101	151	5	3,79	MHSS76	19,75	140	205	5	9,72
MHSS49	13,00	101	151	5	3,79	MHSS77	20,00	140	205	5	9,72
MHSS50	13,25	108	160	5	5,17						
MHSS51	13,50	108	160	5	5,17						
MHSS52	13,75	108	160	5	5,17						



Jogos de brocas HSS em caixa metálica

Código	Ø Medida	€
MHJ01	1-10 x 0,5 (19 brocas)	16,36
MHJ02	1-13 x 0,5 (25 brocas)	36,15

Caixas metálicas vazias para jogos de brocas

Código	Ø Medida	€
MCB100	1-10 x 0,5 (19 brocas)	8,50
MCB101	1-13 x 0,5 (25 brocas)	13,08



Mala metálica de brocas HSS

Composição: 170 brocas		Código: MHJ10
10 brocas de cada:		
Ø 1,00 - 1,50 - 2,00 - 2,50 - 3,00 - 3,50 - 4,00 - 4,50 5,00 - 5,50 - 6,00 - 6,50 - 7,00 - 7,50 - 8,00		
5 brocas de cada:		
Ø 8,50 - 9,00 - 9,50 - 10,00		121,15 €



Expositor em acrílico de brocas HSS

Composição: 707 brocas		Código: MHJ001	
Ø	UNDS	Ø	UNDS
1,00	50	4,00	90
1,50	50	4,25	30
2,00	50	4,50	30
2,50	50	5,00	30
3,00	60	5,50	20
3,25	60	6,00	20
3,50	50	6,50	10
7,00	10	10,00	7
7,50	10	10,50	6
8,00	10	11,00	6
8,50	10	11,50	7
9,00	10	12,00	7
9,50	10	12,50	7
		13,00	7
399,47 €			



Expositor metálico de brocas HSS

Composição: 2150 brocas		Código: MHE1	
Ø	UNDS	Ø	UNDS
1,00	50	4,00	300
1,50	50	4,25	100
2,00	50	4,50	100
2,50	50	5,00	200
3,00	300	5,25	50
3,25	100	5,50	100
3,50	200	6,00	100
6,50	50	10,00	50
7,00	50	10,50	10
7,50	50	11,00	10
8,00	50	11,50	10
8,50	30	12,00	10
9,00	30	12,50	10
9,50	30	13,00	10
1.231,78 €			



Código	Ø	l mm	L mm	PCS	€
MOCO01	1,00	12	34	10	0,35
MOCO02	1,25	16	38	10	0,44
MOCO03	1,50	18	40	10	0,44
MOCO04	1,75	22	46	10	0,48
MOCO05	2,00	24	49	10	0,48
MOCO06	2,25	27	53	10	0,49
MOCO07	2,50	30	57	10	0,49
MOCO08	2,75	33	61	10	0,64
MOCO09	3,00	33	61	10	0,64
MOCO10	3,25	36	65	10	0,69
MOCO11	3,50	39	70	10	0,74
MOCO12	3,75	39	70	10	0,79
MOCO13	4,00	43	75	10	0,79
MOCO14	4,25	43	75	10	0,81
MOCO15	4,50	47	80	10	0,85
MOCO16	4,75	47	80	10	1,01
MOCO17	5,00	52	86	10	1,01
MOCO18	5,25	52	86	10	1,07
MOCO19	5,50	57	93	10	1,07
MOCO20	5,75	57	93	10	1,24
MOCO21	6,00	57	93	10	1,24
MOCO22	6,25	63	101	10	1,48
MOCO23	6,50	63	101	10	1,48
MOCO24	6,75	69	109	10	1,80
MOCO25	7,00	69	109	10	1,80
MOCO26	7,25	69	109	10	2,05
MOCO27	7,50	69	109	10	2,05
MOCO28	7,75	75	117	10	2,43
MOCO29	8,00	75	117	5	2,43
MOCO30	8,25	75	117	5	2,96
MOCO31	8,50	75	117	5	2,96
MOCO32	8,75	81	125	5	3,53
MOCO33	9,00	81	125	5	3,53
MOCO34	9,25	81	125	5	3,88
MOCO35	9,50	81	125	5	3,88
MOCO36	9,75	87	133	5	4,48
MOCO37	10,00	87	133	5	4,48
MOCO38	10,25	87	133	5	4,54
MOCO39	10,50	87	133	5	4,54
MOCO40	10,75	94	142	5	5,26
MOCO41	11,00	94	142	5	5,26
MOCO42	11,25	94	142	5	5,74
MOCO43	11,50	94	142	5	5,74
MOCO44	11,75	94	142	5	6,54
MOCO45	12,00	101	151	5	6,54
MOCO46	12,25	101	151	5	7,04
MOCO47	12,50	101	151	5	7,04
MOCO48	12,75	101	151	5	7,61
MOCO49	13,00	101	151	5	7,61



Jogos de brocas HSS-CO 8% em caixa metálica

Código	Ø Medida	€
MOC01	1-10 x 0,5 (19 brocas)	35,01
MOC02	1-13 x 0,5 (25 brocas)	68,99

Caixas metálicas vazias para jogos de brocas

Código	Ø Medida	€
MCB100	1-10 x 0,5 (19 brocas)	8,50
MCB101	1-13 x 0,5 (25 brocas)	13,08



Mala metálica de brocas HSS-CO 8%

Composição: 170 brocas	Código: MOC10
10 brocas de cada:	
Ø 1,00 - 1,50 - 2,00 - 2,50 - 3,00 - 3,50 - 4,00 - 4,50 5,00 - 5,50 - 6,00 - 6,50 - 7,00 - 7,50 - 8,00	
5 brocas de cada:	
Ø 8,50 - 9,00 - 9,50 - 10,00	274,60 €



Expositor em acrílico de brocas HSS-CO 8%

Composição: 707 brocas		Código: MOJ001					
Ø	UNDS	Ø	UNDS	Ø	UNDS	Ø	UNDS
1,00	50	4,00	90	7,00	10	10,00	7
1,50	50	4,25	30	7,50	10	10,50	6
2,00	50	4,50	30	8,00	10	11,00	6
2,50	50	5,00	30	8,50	10	11,50	7
3,00	60	5,50	20	9,00	10	12,00	7
3,25	60	6,00	20	9,50	10	12,50	7
3,50	50	6,50	10			13,00	7
							876,98 €



Expositor metálico de brocas HSS-CO 8%

Composição: 895 brocas		Código: MOE2					
Ø	UNDS	Ø	UNDS	Ø	UNDS	Ø	UNDS
1,00	20	4,00	100	6,50	20	10,00	20
1,50	20	4,25	50	7,00	20	10,50	5
2,00	20	4,50	50	7,50	10	11,00	5
2,50	50	5,00	100	8,00	20	11,50	5
3,00	100	5,25	30	8,50	10	12,00	10
3,25	50	5,50	50	9,00	10	12,50	5
3,50	50	6,00	50	9,50	10	13,00	5
							1.124,56 €

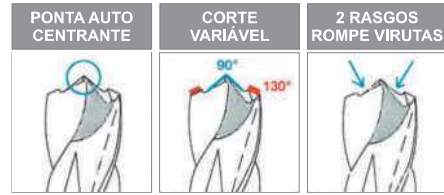

Código	∅	L mm	PCS	€	
MTSP001	1,00	12	34	10	1,03
MTSP002	1,25	16	38	10	1,13
MTSP003	1,50	18	40	10	1,03
MTSP004	1,75	22	46	10	1,13
MTSP005	2,00	24	49	10	1,03
MTSP006	2,25	27	53	10	1,15
MTSP007	2,50	30	57	10	1,05
MTSP008	2,75	33	61	10	1,24
MTSP009	3,00	33	61	10	1,11
MTSP010	3,25	36	65	10	1,45
MTSP011	3,50	39	70	10	1,31
MTSP012	3,75	39	70	10	1,59
MTSP013	4,00	43	75	10	1,45
MTSP014	4,25	43	75	10	1,73
MTSP015	4,50	47	80	10	1,56
MTSP016	4,75	47	80	10	1,98
MTSP017	5,00	52	86	10	1,87
MTSP018	5,25	52	86	10	2,56
MTSP019	5,50	57	93	10	2,32
MTSP020	5,75	57	93	10	2,78
MTSP021	6,00	57	93	10	2,52
MTSP022	6,25	63	101	10	3,27
MTSP023	6,50	63	101	10	2,89
MTSP024	6,75	69	109	10	3,83
MTSP025	7,00	69	109	10	3,47
MTSP026	7,25	69	109	10	4,10
MTSP027	7,50	69	109	5	3,72
MTSP028	7,75	75	117	5	4,82
MTSP029	8,00	75	117	5	4,56
MTSP030	8,25	75	117	5	5,26
MTSP031	8,50	75	117	5	4,95
MTSP032	8,75	81	125	5	6,24
MTSP033	9,00	81	125	5	5,67
MTSP034	9,25	81	125	5	6,61
MTSP035	9,50	81	125	5	6,20
MTSP036	9,75	87	133	5	7,49
MTSP037	10,00	87	133	5	6,96
MTSP038	10,25	87	133	5	8,27
MTSP039	10,50	87	133	5	7,51
MTSP040	10,75	94	142	5	9,59
MTSP041	11,00	94	142	5	8,72
MTSP042	11,25	94	142	5	10,43
MTSP043	11,50	94	142	5	9,47
MTSP044	11,75	94	142	5	11,63
MTSP045	12,00	101	151	5	10,57
MTSP046	12,25	101	151	5	12,54
MTSP047	12,50	101	151	5	11,40
MTSP048	12,75	101	151	5	13,35
MTSP049	13,00	101	151	5	12,15



Jogos em caixa plástica

Código	∅ Medida	€
MTSPJ01	1-10 x 0,5 (19 brocas)	57,55
MTSPJ02	1-13 x 0,5 (25 brocas)	121,87



Mala metálica

Composição: 116 brocas
Código: MTSPJ03
1-10 x 0,5

∅ UNDS	∅ UNDS
1,00 10	5,50 3
1,50 10	6,00 3
2,00 10	6,50 3
2,50 10	7,00 3
3,00 10	7,50 3
3,50 10	8,00 3
4,00 10	8,50 2
4,50 10	9,00 2
5,00 10	9,50 2
	10,00 2

230,63 €

Expositor metálico

Composição: 168 brocas
Código: MTSPJ04
1-13 x 0,5

∅ UNDS	∅ UNDS
1,00 10	7,00 5
1,50 10	7,50 5
2,00 10	8,00 5
2,50 10	8,50 5
3,00 10	9,00 5
3,50 10	9,50 5
4,00 10	10,00 5
4,50 10	10,50 3
5,00 10	11,00 3
5,50 10	11,50 3
6,00 10	12,00 3
6,50 5	12,50 3
	13,00 3

533,77 €

Brocas cilíndricas rebaixadas HSS



Brocas cilíndricas rebaixadas HSS-CO

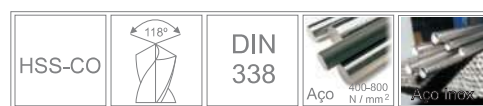

Código	∅	l mm	L mm	PCS	€
MHSSR01	13,50	76	156	1	5,57
MHSSR02	14,00	76	156	1	5,57
MHSSR03	14,50	76	156	1	5,87
MHSSR04	15,00	76	156	1	5,87
MHSSR05	15,50	76	156	1	6,48
MHSSR06	16,00	76	156	1	6,48
MHSSR07	16,50	76	156	1	6,87
MHSSR08	17,00	76	156	1	7,21
MHSSR09	17,50	76	156	1	7,27
MHSSR10	18,00	76	156	1	7,27
MHSSR11	18,50	76	156	1	7,57
MHSSR12	19,00	76	156	1	8,04
MHSSR13	19,50	76	156	1	8,37
MHSSR14	20,00	76	156	1	8,93
MHSSR15	21,00	76	156	1	9,80
MHSSR16	22,00	76	156	1	11,71
MHSSR17	23,00	76	156	1	12,28
MHSSR18	24,00	76	156	1	14,48
MHSSR19	25,00	76	156	1	15,29

Código	∅	l mm	L mm	PCS	€
MOCOR01	13,50	76	156	1	7,92
MOCOR02	14,00	76	156	1	8,51
MOCOR03	14,50	76	156	1	8,52
MOCOR04	15,00	76	156	1	9,16
MOCOR05	15,50	76	156	1	10,80
MOCOR06	16,00	76	156	1	10,80
MOCOR07	16,50	76	156	1	11,45
MOCOR08	17,00	76	156	1	12,39
MOCOR09	17,50	76	156	1	12,39
MOCOR10	18,00	76	156	1	12,39
MOCOR11	18,50	76	156	1	12,58
MOCOR12	19,00	76	156	1	12,58
MOCOR13	19,50	76	156	1	13,79
MOCOR14	20,00	76	156	1	15,22
MOCOR15	21,00	76	156	1	15,22
MOCOR16	22,00	76	156	1	18,49
MOCOR17	23,00	76	156	1	18,49
MOCOR18	24,00	76	156	1	21,01
MOCOR19	25,00	76	156	1	23,62

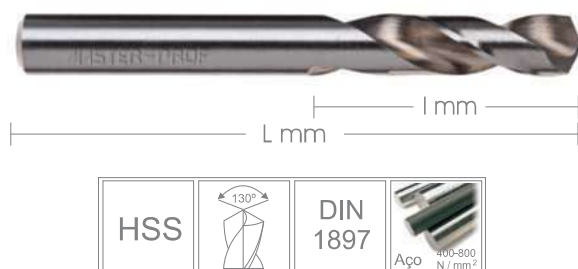

Código	∅	l mm	L mm	PCS	€
MHSE01	2,00	12	38	10	0,53
MHSE02	2,25	13	40	10	0,62
MHSE03	2,50	14	43	10	0,60
MHSE04	2,75	16	46	10	0,81
MHSE05	3,00	16	46	10	0,80
MHSE06	3,25	18	49	10	0,82
MHSE07	3,50	20	52	10	0,85
MHSE08	3,75	20	52	10	0,90
MHSE09	4,00	22	55	10	0,85
MHSE10	4,25	22	55	10	0,77
MHSE11	4,50	24	58	10	0,90
MHSE12	4,75	24	58	10	0,92
MHSE13	5,00	26	62	10	0,92
MHSE14	5,25	26	62	10	1,02
MHSE15	5,50	28	66	10	1,02
MHSE16	5,75	28	66	10	1,22
MHSE17	6,00	28	66	10	1,15
MHSE18	6,50	31	70	10	1,72
MHSE19	7,00	34	74	10	1,92
MHSE20	7,50	34	74	5	2,31
MHSE21	8,00	37	79	5	2,81
MHSE22	8,50	37	79	5	3,46
MHSE23	9,00	40	84	5	4,16
MHSE24	9,50	40	84	5	4,89
MHSE25	10,00	43	89	5	5,47

Jogo de brocas Extra Curta em caixa metálica

Código	∅ Medida	€
MHSE90	2-10 x 0,5mm (19 brocas)	42,78





Código	Ø	I mm	L mm	PCS	€
MHSSL001	1,50	45	70	10	1,37
MHSSL002	1,75	53	80	10	1,53
MHSSL003	2,00	56	85	10	1,46
MHSSL004	2,25	59	90	10	1,60
MHSSL005	2,50	62	95	10	1,53
MHSSL006	2,75	66	100	10	1,77
MHSSL007	3,00	66	100	10	1,77
MHSSL008	3,25	69	106	10	1,92
MHSSL009	3,50	73	112	10	1,88
MHSSL010	3,75	73	112	10	2,00
MHSSL011	4,00	78	119	10	1,91
MHSSL012	4,25	78	119	10	2,42
MHSSL013	4,50	82	126	10	2,45
MHSSL014	4,75	82	126	10	2,52
MHSSL015	5,00	87	132	10	2,39
MHSSL016	5,25	87	132	10	3,31
MHSSL017	5,50	91	139	10	3,31
MHSSL018	5,75	91	139	10	3,62
MHSSL019	6,00	91	139	10	3,62
MHSSL020	6,25	97	148	10	4,09
MHSSL021	6,50	97	148	10	3,89
MHSSL022	6,75	97	148	10	4,76
MHSSL023	7,00	102	156	10	4,37
MHSSL024	7,25	102	156	10	5,38
MHSSL025	7,50	102	156	10	5,11
MHSSL026	7,75	109	165	10	6,12
MHSSL027	8,00	109	165	5	5,82
MHSSL028	8,25	109	165	5	8,05

Código	Ø	I mm	L mm	PCS	€
MHSSL029	8,50	109	165	5	8,05
MHSSL030	8,75	115	175	5	8,43
MHSSL031	9,00	115	175	5	8,43
MHSSL032	9,25	115	175	5	9,47
MHSSL033	9,50	115	175	5	9,03
MHSSL034	9,75	121	184	5	9,35
MHSSL035	10,00	121	184	5	8,90
MHSSL036	10,50	121	184	5	10,73
MHSSL037	11,00	128	195	5	10,91
MHSSL038	11,50	128	195	5	12,04
MHSSL039	12,00	134	205	5	13,12
MHSSL040	12,50	134	205	5	13,56
MHSSL041	13,00	134	205	5	15,88
MHSSL042	13,50	140	214	5	21,89
MHSSL043	14,00	140	214	5	21,89
MHSSL044	14,50	144	220	5	30,99
MHSSL045	15,00	144	220	5	29,53
MHSSL046	15,50	149	227	5	35,98
MHSSL047	16,00	149	227	5	34,27
MHSSL048	16,50	154	235	5	35,53
MHSSL049	17,00	154	235	5	36,52
MHSSL050	17,50	158	241	5	40,54
MHSSL051	18,00	158	241	5	41,22
MHSSL052	18,50	162	247	5	46,80
MHSSL053	19,00	162	247	5	47,74
MHSSL054	19,50	166	254	5	50,58
MHSSL055	20,00	166	254	5	51,15

Brocas cilíndricas HSS-CO DIN338
Split Point 135° Helicoidal 40° para INOX



Código	∅	l mm	L mm	PCS	€
MRIO02	1,00	12	34	10	0,50
MRIO04	1,50	18	40	10	0,62
MRIO07	2,25	27	53	10	0,69
MRIO09	2,75	33	61	10	0,70
MRIO10	3,00	33	61	10	0,70
MRIO13	3,75	39	70	10	0,98
MRIO16	4,50	47	80	10	1,12
MRIO17	4,75	47	80	10	1,15
MRIO18	5,00	52	86	10	1,22
MRIO22	6,00	57	93	10	1,68
MRIO24	6,50	63	101	10	2,02
MRIO28	7,50	69	109	10	2,71
MRIO30	8,00	75	117	10	3,22
MRIO32	8,50	75	117	10	3,55
MRIO36	9,50	81	125	10	4,59
Até fim de existencias					

Brocas cilíndricas com ponta em metal duro



Código	∅	l mm	L mm	PCS	€
MBO200	2,00	24	49	1	14,41
MBO202	2,50	30	57	1	12,69
MBO204	3,00	33	61	1	14,41
MBO206	3,50	39	70	1	14,41
MBO208	4,00	43	75	1	11,53
MBO210	4,50	47	80	1	11,53
MBO212	5,00	52	86	1	12,85
MBO214	5,50	57	93	1	12,85
MBO216	6,00	57	93	1	13,61
MBO218	6,50	63	103	1	13,90
MBO220	7,00	69	109	1	15,33
MBO222	7,50	69	109	1	16,12
MBO224	8,00	75	117	1	18,60
MBO226	8,50	75	117	1	18,13
MBO228	9,00	81	125	1	20,43
MBO230	9,50	81	125	1	22,42
MBO232	10,00	87	133	1	23,28
MBO234	10,50	94	142	1	25,50
MBO236	11,00	94	142	1	27,49
MBO238	11,50	94	142	1	29,20
MBO240	12,00	101	151	1	31,54
MBO242	12,50	101	151	1	33,44
MBO244	13,00	101	151	1	36,90

Brocas cilíndricas para alumínio



Código	∅	l mm	L mm	PCS	€
MBA0007	1,50	18	40	1	2,06
MBA0010	1,75	22	46	1	1,75
MBA0016	2,25	27	53	1	2,45
MBA0022	2,75	33	61	1	2,65
MBA0040	4,25	43	75	1	3,92
MBA0046	4,75	47	80	1	3,96
MBA0055	5,50	57	93	1	4,60
MBA0058	5,75	57	93	1	5,06
MBA0061	6,00	57	93	1	4,60
MBA0064	6,25	63	101	1	6,06
MBA0067	6,50	63	101	1	5,25
MBA0070	6,75	69	109	1	6,16
MBA0073	7,00	69	109	1	5,61
MBA0076	7,25	69	109	1	7,40
MBA0079	7,50	69	109	1	7,40
MBA0082	7,75	75	117	1	9,37
MBA0085	8,00	75	117	1	8,43
MBA0088	8,25	75	117	1	10,04
MBA0091	8,50	75	117	1	9,29
MBA0094	8,75	81	125	1	10,48
MBA0097	9,00	81	125	1	9,59
MBA0100	9,25	81	125	1	10,93
MBA0103	9,50	81	125	1	10,48
MBA0106	9,75	87	133	1	11,60
MBA0115	10,50	87	133	1	11,82
MBA0118	10,75	94	142	1	13,76
MBA0121	11,00	94	142	1	14,28
MBA0124	11,25	94	142	1	18,13
MBA0127	11,50	94	142	1	16,86
MBA0130	11,75	94	142	1	17,77
MBA0136	12,25	101	151	1	24,71
MBA0139	12,50	101	151	1	18,74
MBA0142	12,75	101	151	1	24,15
MBA0145	13,00	101	151	1	18,00

Até fim de existências

Brocas cilíndricas para latão



Código	∅	l mm	L mm	PCS	€
MBL0001	1,00	12	34	1	2,43
MBL0004	1,25	16	38	1	2,75
MBL0010	1,75	22	46	1	2,68
MBL0025	3,00	33	61	1	2,32
MBL0034	3,75	39	70	1	3,05
MBL0037	4,00	43	75	1	2,77
MBL0043	4,50	47	80	1	3,35
MBL0058	5,75	57	93	1	4,87
MBL0067	6,50	63	101	1	5,29
MBL0073	7,00	69	109	1	5,39
MBL0076	7,25	69	109	1	7,12
MBL0082	7,75	87	133	1	8,58
MBL0109	10,00	87	133	1	9,80
MBL0115	10,50	87	133	1	10,83
MBL0124	11,25	94	142	1	20,31
MBL0127	11,50	94	142	1	15,44
MBL0130	11,75	94	142	1	20,30
MBL0136	12,25	101	151	1	27,68
MBL0139	12,50	101	151	1	18,74
MBL0142	12,75	101	151	1	27,70
MBL0145	13,00	101	151	1	17,16

Até fim de existências

Brocas cilíndricas perfil "S" HSS-CO



Código	∅	l mm	L mm	PCS	€
MBS001	1,50	45	70	1	5,24
MBS004	2,00	56	85	1	4,97
MBS024	6,50	97	148	1	9,92
MBS027	7,00	102	156	1	9,38
MBS030	8,50	109	165	1	13,05
MBS032	9,50	115	175	1	14,64
MBS034	10,50	121	184	1	19,90
MBS036	11,50	128	195	1	26,54
MBS037	12,00	134	205	1	26,54
MBS039	13,00	134	205	1	41,28

Até fim de existências



Código	∅	l mm	L mm	CM	PCS	€
MICON011	10,00	87	168	1	1	4,33
MICON013	11,00	94	175	1	1	4,33
MICON015	12,00	101	182	1	1	4,71
MICON017	13,00	101	182	1	1	5,26
MICON018	13,50	108	189	1	1	5,26
MICON019	14,00	108	189	1	1	6,05
MICON020	14,50	114	212	2	1	6,77
MICON021	15,00	114	212	2	1	6,77
MICON022	15,50	120	218	2	1	6,77
MICON023	16,00	120	218	2	1	6,77
MICON024	16,50	125	223	2	1	7,38
MICON025	17,00	125	223	2	1	7,82
MICON026	17,50	130	228	2	1	7,82
MICON027	18,00	130	228	2	1	8,48
MICON028	18,50	130	228	2	1	8,72
MICON029	19,00	135	233	2	1	9,61
MICON030	19,50	140	238	2	1	10,90
MICON031	20,00	140	238	2	1	11,58
MICON032	20,50	150	248	2	1	12,23
MICON033	21,00	150	248	2	1	12,73
MICON034	21,50	150	248	2	1	13,00
MICON035	22,00	150	248	2	1	13,87
MICON036	22,50	155	253	2	1	14,09
MICON037	23,00	155	253	2	1	15,01
MICON038	23,50	155	276	3	1	17,41
MICON039	24,00	160	281	3	1	17,41
MICON040	24,50	160	281	3	1	17,41
MICON041	25,00	160	281	3	1	18,68
MICON042	25,50	165	286	3	1	19,06
MICON043	26,00	165	286	3	1	20,46
MICON044	26,50	165	286	3	1	20,46
MICON045	27,00	170	291	3	1	21,76
MICON046	27,50	170	291	3	1	23,94
MICON047	28,00	170	291	3	1	23,94
MICON048	28,50	175	296	3	1	23,94
MICON049	29,00	175	296	3	1	25,67
MICON050	29,50	175	296	3	1	25,67
MICON051	30,00	175	296	3	1	29,34
MICON052	30,50	180	301	3	1	29,34
MICON053	31,00	180	301	3	1	33,86
MICON054	31,50	180	301	3	1	33,86
MICON055	32,00	185	334	4	1	37,63
MICON056	32,50	185	334	4	1	38,27
MICON057	33,00	185	334	4	1	41,29
MICON058	33,50	185	334	4	1	42,16
MICON059	34,00	190	339	4	1	42,16
MICON060	34,50	190	339	4	1	45,21
MICON061	35,00	190	339	4	1	46,53

Código	∅	l mm	L mm	CM	PCS	€
MICON062	35,50	190	339	4	1	50,00
MICON063	36,00	195	344	4	1	50,29
MICON064	36,50	195	344	4	1	53,89
MICON065	37,00	195	344	4	1	55,41
MICON066	37,50	195	344	4	1	55,41
MICON067	38,00	200	349	4	1	55,41
MICON068	38,50	200	349	4	1	55,41
MICON069	39,00	200	349	4	1	62,97
MICON070	39,50	200	349	4	1	62,97
MICON071	40,00	205	354	4	1	62,97
MICON072	40,50	205	354	4	1	62,97
MICON073	41,00	205	354	4	1	68,14
MICON074	41,50	205	354	4	1	68,14
MICON075	42,00	205	354	4	1	68,75
MICON076	42,50	210	359	4	1	70,11
MICON077	43,00	210	359	4	1	68,75
MICON078	43,50	210	359	4	1	76,88
MICON079	44,00	210	359	4	1	86,27
MICON080	44,50	210	359	4	1	92,16
MICON081	45,00	210	359	4	1	86,27
MICON082	45,50	215	364	4	1	89,98
MICON083	46,00	215	364	4	1	87,33
MICON084	46,50	215	364	4	1	98,94
MICON085	47,00	215	364	4	1	104,51
MICON086	47,50	215	364	4	1	108,11
MICON087	48,00	220	369	4	1	104,51
MICON088	48,50	220	369	4	1	117,72
MICON089	49,00	220	369	4	1	104,51
MICON090	49,50	220	369	4	1	120,78
MICON091	50,00	220	369	4	1	109,73
MICON092	51,00	225	412	5	1	133,66
MICON093	52,00	225	412	5	1	133,66
MICON094	53,00	225	412	5	1	133,66
MICON095	54,00	230	417	5	1	144,81
MICON096	55,00	230	417	5	1	144,81
MICON097	56,00	230	417	5	1	163,30
MICON098	57,00	235	422	5	1	163,30
MICON099	58,00	235	422	5	1	175,28
MICON100	59,00	235	422	5	1	175,28
MICON101	60,00	235	422	5	1	175,28
MICON102	61,00	240	427	5	1	246,67
MICON103	62,00	240	427	5	1	246,67
MICON104	63,00	240	427	5	1	246,67
MICON105	64,00	245	432	5	1	263,29
MICON106	65,00	245	432	5	1	263,29

Outras medidas sob consulta



Expositor

Composição: 25 brocas
Código: MIE1000

Ø	UNDS	Ø	UNDS
14,00	1	20,00	1
14,50	1	20,50	1
15,00	1	21,00	1
15,50	1	21,50	1
16,00	1	22,00	1
16,50	1	22,50	1
17,00	1	23,00	1
17,50	1	24,00	1
18,00	1	25,00	1
18,50	1	26,00	1
19,00	1	27,00	1
19,50	1	28,00	1
		30,00	1

330,27 €



Expositor

Composição: 10 brocas
Código: MIE1001

Ø	UNDS
14,00	1
15,00	1
16,00	1
17,00	1
18,00	1
19,00	1
20,00	1
21,00	1
22,00	1
25,00	1

102,36 €

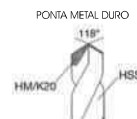

Código	Ø	M.K.	l mm	L mm	PCS	€
MICMD01	10,00	1	87	168	1	76,44
MICMD02	10,50	1	87	168	1	76,44
MICMD03	11,00	1	94	175	1	76,44
MICMD04	11,50	1	94	175	1	79,82
MICMD05	12,00	1	101	182	1	79,82
MICMD06	12,50	1	101	182	1	85,31
MICMD07	13,00	1	101	182	1	85,31
MICMD08	13,50	1	108	189	1	98,82
MICMD09	14,00	1	108	189	1	98,82
MICMD10	15,00	2	114	212	1	101,36
MICMD11	16,00	2	120	218	1	105,59
MICMD12	17,00	2	125	223	1	115,72
MICMD13	18,00	2	130	228	1	115,72
MICMD14	19,00	2	135	233	1	122,48
MICMD15	20,00	2	140	238	1	157,11
MICMD16	21,00	2	145	243	1	168,94
MICMD17	22,00	2	150	248	1	173,16
MICMD18	23,00	2	155	253	1	177,38
MICMD19	24,00	3	160	281	1	184,14
MICMD20	25,00	3	160	281	1	194,28
MICMD21	26,00	3	165	286	1	242,42
MICMD22	27,00	3	170	291	1	251,72
MICMD23	28,00	3	170	291	1	265,23
MICMD24	29,00	3	175	296	1	295,64
MICMD25	30,00	3	175	296	1	318,46
MICMD26	31,00	3	180	301	1	334,16
MICMD27	32,00	4	185	334	1	383,88
MICMD28	33,00	4	185	334	1	401,38
MICMD29	34,00	4	190	339	1	412,26
MICMD30	35,00	4	190	339	1	422,74

Condições de corte

Material	Vc MD / HM	Avanço mm/rev.						
		Ø8	Ø10	Ø12	Ø16	Ø20	Ø25	Ø30
Aços aleados	30 - 50	0,045	0,050	0,055	0,070	0,080	0,080	0,090
Aços tratados	10 - 15	0,040	0,040	0,050	0,050	0,060	0,070	0,080
Aço inox	10 - 25	0,040	0,040	0,050	0,050	0,060	0,070	0,080
Fundição	50 - 90	0,060	0,070	0,080	0,100	0,120	0,140	0,160
Titânio	20 - 35	0,035	0,050	0,060	0,080	0,090	0,120	0,150
Cobre/Bronze/Latão	40 - 100	0,100	0,120	0,140	0,160	0,180	0,180	0,200
Plásticos	20 - 100	0,060	0,065	0,070	0,080	0,120	0,150	0,200



Código	Ø	M.K.	l mm	L mm	PCS	€
MICR01	10,00	2	116	233	1	237,95
MICR02	11,00	2	125	242	1	256,51
MICR03	12,00	2	134	251	1	256,78
MICR04	13,00	2	134	251	1	229,53
MICR05	14,00	2	142	259	1	266,64
MICR06	15,00	2	147	264	1	302,06
MICR07	16,00	2	153	270	1	342,18
MICR08	17,00	2	159	276	1	323,61
MICR09	18,00	2	165	282	1	334,13
MICR10	19,00	3	171	307	1	477,71
MICR11	20,00	3	177	313	1	409,61
MICR12	21,00	3	184	320	1	465,09
MICR13	22,00	3	191	327	1	474,91
MICR14	23,00	3	198	334	1	516,57
MICR15	24,00	3	206	342	1	527,01
MICR16	25,00	3	206	342	1	544,15
MICR17	26,00	3	214	350	1	559,29
MICR18	27,00	4	222	385	1	689,73
MICR19	28,00	4	222	385	1	669,47
MICR20	29,00	4	230	393	1	714,63
MICR21	30,00	4	230	393	1	723,94
MICR22	32,00	4	248	421	1	787,36

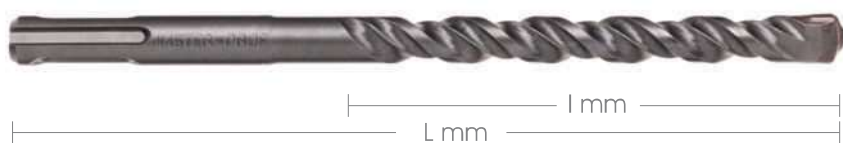

Código	∅	l mm	L mm	PCS	€
MTSDS001	4,00	50	110	1	5,08
MTSDS002	5,00	50	110	1	3,20
MTSDS003	5,00	100	160	1	3,39
MTSDS004	5,00	150	210	1	6,20
MTSDS005	5,00	250	310	1	7,07
MTSDS006	5,50	50	110	1	3,42
MTSDS007	5,50	100	160	1	4,53
MTSDS093	5,50	150	210	1	6,17
MTSDS008	6,00	50	110	1	3,20
MTSDS009	6,00	100	160	1	3,64
MTSDS010	6,00	150	210	1	4,26
MTSDS011	6,00	200	260	1	5,57
MTSDS012	6,00	400	460	1	7,95
MTSDS013	6,50	50	110	1	3,98
MTSDS014	6,50	100	160	1	4,14
MTSDS015	6,50	150	210	1	6,64
MTSDS016	7,00	50	110	1	3,88
MTSDS017	7,00	100	160	1	4,51
MTSDS018	7,00	150	210	1	6,04
MTSDS019	8,00	50	110	1	3,11
MTSDS020	8,00	100	160	1	4,59
MTSDS021	8,00	150	210	1	4,73
MTSDS022	8,00	200	260	1	6,27
MTSDS023	8,00	250	310	1	7,96
MTSDS025	8,00	400	460	1	13,03
MTSDS026	8,00	550	610	1	16,15
MTSDS027	9,00	100	160	1	5,66
MTSDS028	9,00	150	210	1	6,17
MTSDS029	10,00	50	110	1	3,88
MTSDS030	10,00	100	160	1	4,80
MTSDS031	10,00	150	210	1	5,72
MTSDS032	10,00	200	260	1	6,72
MTSDS033	10,00	250	310	1	7,10
MTSDS034	10,00	400	460	1	10,39
MTSDS035	10,00	550	610	1	15,78
MTSDS036	10,00	950	1000	1	36,74
MTSDS037	11,00	100	160	1	6,03
MTSDS038	11,00	150	210	1	6,94
MTSDS039	11,00	200	260	1	7,20
MTSDS040	12,00	100	160	1	4,92
MTSDS041	12,00	150	210	1	8,60
MTSDS042	12,00	200	260	1	8,66
MTSDS043	12,00	250	310	1	11,25
MTSDS044	12,00	400	460	1	16,82
MTSDS045	12,00	550	610	1	20,21
MTSDS046	12,00	950	1000	1	42,84

Código	∅	l mm	L mm	PCS	€
MTSDS047	13,00	100	160	1	7,79
MTSDS048	13,00	150	210	1	10,21
MTSDS049	13,00	200	260	1	11,25
MTSDS050	14,00	100	160	1	7,76
MTSDS051	14,00	150	210	1	11,79
MTSDS052	14,00	200	260	1	12,23
MTSDS053	14,00	250	310	1	13,81
MTSDS054	14,00	400	460	1	17,73
MTSDS055	14,00	550	610	1	29,00
MTSDS056	14,00	950	1000	1	53,66
MTSDS057	15,00	100	160	1	11,58
MTSDS058	15,00	200	260	1	14,01
MTSDS060	16,00	150	210	1	13,27
MTSDS061	16,00	200	260	1	15,78
MTSDS062	16,00	250	310	1	16,09
MTSDS063	16,00	400	460	1	22,22
MTSDS064	16,00	550	610	1	27,41
MTSDS065	16,00	750	800	1	42,70
MTSDS066	16,00	950	1000	1	53,76
MTSDS067	18,00	150	200	1	18,35
MTSDS068	18,00	200	250	1	19,83
MTSDS069	18,00	250	300	1	21,20
MTSDS070	18,00	400	450	1	27,39
MTSDS071	18,00	550	600	1	47,14
MTSDS072	18,00	950	1000	1	61,59
MTSDS073	19,00	150	200	1	21,09
MTSDS074	20,00	150	200	1	21,09
MTSDS075	20,00	250	300	1	24,49
MTSDS076	20,00	400	450	1	30,58
MTSDS077	20,00	550	600	1	45,74
MTSDS078	20,00	950	1000	1	70,79
MTSDS079	22,00	200	250	1	26,29
MTSDS081	22,00	400	450	1	39,19
MTSDS082	22,00	550	600	1	45,74
MTSDS083	22,00	950	1000	1	81,39
MTSDS084	24,00	200	250	1	31,89
MTSDS085	24,00	400	450	1	44,64
MTSDS086	25,00	200	250	1	32,29
MTSDS087	25,00	400	450	1	49,67
MTSDS088	25,00	950	1000	1	109,84
MTSDS089	26,00	200	250	1	37,65
MTSDS090	26,00	400	450	1	49,33
MTSDS092	30,00	400	450	1	83,43



Expositor

Comp.: 99 brocas		Código: MTSDSE01	
∅	UN	∅	UN
5,00 x 110	5	10,00 x 210	5
6,00 x 110	5	12,00 x 210	5
5,00 x 160	5	14,00 x 210	5
6,00 x 160	10	16,00 x 210	3
8,00 x 160	10	8,00 x 260	5
9,00 x 160	5	10,00 x 260	5
10,00 x 160	5	12,00 x 260	5
12,00 x 160	5	14,00 x 260	3
6,00 x 210	5	16,00 x 260	3
8,00 x 210	5		
OFERTA EXPOSITOR	615,62 €		



Jogo brocas caixa plástica
Comp.: 6 brocas
Código: MTSDS300

∅	UN
5,00 x 110	1
6,00 x 110	1
8,00 x 110	1
6,00 x 160	1
8,00 x 160	1
10,00 x 160	1
26,59 €	



Código	∅	l mm	L mm	PCS	€	Código	∅	l mm	L mm	PCS	€
MT4X4001	5,00	50	110	1	5,37	MT4X4032	12,00	250	310	1	17,75
MT4X4002	5,00	100	160	1	5,76	MT4X4033	12,00	400	450	1	25,62
MT4X4003	5,50	50	110	1	5,71	MT4X4034	12,00	950	1000	1	93,70
MT4X4004	5,50	100	160	1	6,19	MT4X4035	14,00	100	160	1	12,70
MT4X4005	6,00	50	110	1	5,43	MT4X4036	14,00	150	210	1	16,97
MT4X4006	6,00	100	160	1	5,95	MT4X4037	14,00	200	260	1	19,49
MT4X4007	6,00	150	210	1	7,44	MT4X4038	14,00	250	310	1	21,90
MT4X4008	6,00	200	260	1	8,94	MT4X4039	14,00	400	450	1	27,50
MT4X4009	6,00	250	310	1	12,78	MT4X4040	14,00	950	1000	1	97,23
MT4X4010	6,50	100	160	1	7,56	MT4X4041	16,00	100	160	1	21,90
MT4X4011	6,50	150	210	1	10,19	MT4X4042	16,00	150	210	1	24,67
MT4X4012	6,50	200	260	1	13,66	MT4X4043	16,00	200	260	1	26,22
MT4X4013	6,50	250	310	1	15,89	MT4X4044	16,00	250	310	1	29,58
MT4X4014	7,00	50	110	1	7,18	MT4X4045	16,00	400	450	1	35,11
MT4X4015	7,00	100	160	1	7,58	MT4X4046	16,00	950	1000	1	102,58
MT4X4016	8,00	50	110	1	6,33	MT4X4047	18,00	200	250	1	35,97
MT4X4017	8,00	100	160	1	6,68	MT4X4048	18,00	400	450	1	42,46
MT4X4018	8,00	150	210	1	7,58	MT4X4049	20,00	200	250	1	42,52
MT4X4019	8,00	200	260	1	9,22	MT4X4050	20,00	400	450	1	48,90
MT4X4020	8,00	250	310	1	13,74	MT4X4051	22,00	200	250	1	45,06
MT4X4021	8,00	400	460	1	19,40	MT4X4052	22,00	400	450	1	56,76
MT4X4022	10,00	50	110	1	7,57	MT4X4053	24,00	200	250	1	52,09
MT4X4023	10,00	100	160	1	8,10	MT4X4054	24,00	400	450	1	62,77
MT4X4024	10,00	150	210	1	9,54	MT4X4055	25,00	200	250	1	53,93
MT4X4025	10,00	200	260	1	11,61	MT4X4056	25,00	400	450	1	66,10
MT4X4026	10,00	250	310	1	14,04	MT4X4057	28,00	200	250	1	63,56
MT4X4027	10,00	400	450	1	24,48	MT4X4058	28,00	400	450	1	69,88
MT4X4028	10,00	950	1000	1	88,75	MT4X4059	30,00	200	250	1	67,01
MT4X4029	12,00	100	160	1	9,35	MT4X4060	30,00	400	450	1	91,41
MT4X4030	12,00	150	210	1	11,37	MT4X4061	32,00	400	450	1	98,40
MT4X4031	12,00	200	260	1	12,95						



Jogo brocas caixa plástica

Comp.:7 brocas
Cód.:MT4X4400

∅	UN
5,00 x 110	1
6,00 x 110	1
8,00 x 110	1
6,00 x 160	1
8,00 x 160	1
10,00 x 160	1
12,00 x 160	1

48,70 €



Expositor

Comp.:99 brocas Código:MT4X4200

∅	UN	∅	UN
5,00 x 110	5	8,00 x 210	5
6,00 x 110	5	10,00 x 210	5
7,00 x 110	5	12,00 x 210	5
8,00 x 110	5	14,00 x 210	3
10,00 x 110	5	10,00 x 260	5
6,00 x 160	10	12,00 x 260	5
8,00 x 160	10	14,00 x 260	5
10,00 x 160	5	12,00 x 310	3
12,00 x 160	5	14,00 x 310	3
14,00 x 160	5		

OFERTA EXPOSITOR 968,92 €

Características: a ponta em metal duro monobloco com 4 cortes, garante uma grande capacidade de corte assim como uma grande saída dos materiais graças à combinação das 4 pastilhas do bloco integral e das 4 hélices.

Vantagens: grande rendimento de corte, precisão de furação, grande duração da broca e máxima limitação de vibração do martelo.



4 CORTES



Código	∅	l mm	L mm	PCS	€
MBMA001	12,00	200	340	1	35,41
MBMA002	12,00	400	540	1	49,72
MBMA003	12,00	600	740	1	69,64
MBMA004	14,00	200	340	1	36,08
MBMA005	14,00	400	540	1	49,72
MBMA006	16,00	200	340	1	42,10
MBMA007	16,00	400	540	1	51,70
MBMA008	18,00	200	340	1	44,65
MBMA009	18,00	400	540	1	57,02
MBMA010	18,00	800	940	1	88,11
MBMA011	20,00	200	320	1	49,31
MBMA012	20,00	400	520	1	61,68
MBMA013	20,00	800	920	1	82,95
MBMA014	20,00	1200	1320	1	241,89
MBMA015	22,00	200	320	1	52,42
MBMA016	22,00	400	520	1	67,19
MBMA017	22,00	800	920	1	93,30
MBMA018	22,00	1200	1320	1	241,89
MBMA019	24,00	200	320	1	61,07
MBMA020	24,00	400	520	1	72,58
MBMA021	25,00	200	320	1	72,58
MBMA022	25,00	400	520	1	78,57
MBMA023	25,00	800	920	1	126,13
MBMA024	25,00	1200	1320	1	228,08
MBMA025	26,00	400	520	1	80,74
MBMA026	28,00	250	370	1	83,37
MBMA027	28,00	450	570	1	89,74
MBMA028	30,00	250	370	1	85,81
MBMA029	30,00	450	570	1	103,95
MBMA030	32,00	250	370	1	116,65
MBMA031	32,00	450	570	1	110,21
MBMA032	32,00	800	920	1	169,26
MBMA033	32,00	1200	1320	1	295,44
MBMA038	35,00	450	570	1	125,16
MBMA034	38,00	250	370	1	128,71
MBMA035	38,00	450	570	1	136,45
MBMA036	40,00	450	570	1	160,41
MBMA037	40,00	800	920	1	225,70



Expositor

Composição: 22 brocas Código: MBMA999

UNDS	∅	UNDS	∅
2	12,00x200x340	2	20,00x400x520
2	14,00x200x340	1	22,00x200x320
2	16,00x200x340	1	24,00x200x320
2	16,00x400x540	1	25,00x200x320
2	18,00x200x340	1	28,00x450x570
2	18,00x400x540	1	30,00x450x570
2	20,00x200x320	1	38,00x450x570

OFERTA EXPOSITOR 1279,71 €



Código	∅	l mm	L mm	PCS	€
MNBP100	3,00	30	60	1	0,43
MNBP122	3,50	35	60	1	0,44
MNBP101	4,00	40	75	1	0,46
MNBP121	4,50	40	75	1	0,49
MNBP102	5,00	40	85	1	0,57
MNBP103	5,50	45	85	1	0,64
MNBP104	6,00	65	120	1	0,57
MNBP106	7,00	55	100	1	0,70
MNBP107	8,00	70	120	1	0,84
MNBP108	9,00	70	120	1	1,15
MNBP109	10,00	70	120	1	1,45
MNBP110	11,00	90	150	1	2,03
MNBP111	12,00	90	150	1	1,93
MNBP112	13,00	90	150	1	2,40
MNBP113	14,00	90	150	1	2,39
MNBP115	16,00	90	150	1	2,59
MNBP116	18,00	100	160	1	4,52
MNBP117	19,00	100	160	1	4,79
MNBP118	20,00	100	160	1	4,79
MNBP119	22,00	100	160	1	6,34
MNBP120	25,00	100	160	1	7,60



Jogo brocas em caixa plástica

Comp.: 8 brocas
Código: MNBE02

∅	UN
3,00	1
4,00	1
5,00	1
6,00	1
7,00	1
8,00	1
9,00	1
10,00	1

11,81 €



Longas comprimento de 300mm e 400mm

Código	∅	l mm	L mm	PCS	€
MNBPL50	6,00 x 300	230	300	1	1,86
MNBPL52	8,00 x 300	210	300	1	2,79
MNBPL53	10,00 x 300	210	300	1	3,57
MNBPL54	12,00 x 300	210	300	1	4,82
MNBPL55	14,00 x 300	210	300	1	5,67
MNBPL56	16,00 x 300	210	300	1	6,45
MNBPL57	18,00 x 300	210	300	1	6,54
MNBPL58	20,00 x 300	210	300	1	7,40
MNBPL59	22,00 x 300	210	300	1	8,26
MNBPL60	25,00 x 300	210	300	1	10,28
MNBPL70	8,00 x 400	300	400	1	4,58
MNBPL71	10,00 x 400	300	400	1	6,14
MNBPL72	12,00 x 400	300	400	1	6,33
MNBPL73	14,00 x 400	300	400	1	6,70
MNBPL74	16,00 x 400	300	400	1	7,51
MNBPL75	18,00 x 400	300	400	1	8,65
MNBPL76	20,00 x 400	300	400	1	9,53
MNBPL77	22,00 x 400	300	400	1	10,39
MNBPL78	25,00 x 400	300	400	1	11,69

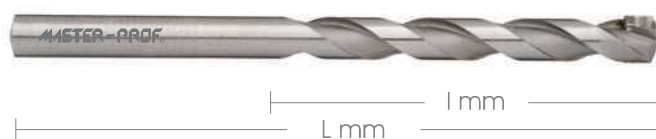

Código	∅	l mm	L mm	PCS	€
MTFT01	3,00	40	70	1	1,84
MTFT02	4,00	40	75	1	1,84
MTFT03	5,00	40	85	1	1,84
MTFT04	6,00	55	100	1	1,92
MTFT05	7,00	55	100	1	2,18
MTFT06	8,00	70	120	1	2,33
MTFT07	9,00	70	120	1	2,75
MTFT08	10,00	70	120	1	2,92
MTFT09	11,00	90	150	1	3,99
MTFT10	12,00	90	150	1	3,99
MTFT11	13,00	90	150	1	5,75
MTFT12	14,00	90	150	1	6,82
MTFT13	15,00	90	150	1	8,98
MTFT14	16,00	90	150	1	8,98



Jogos de brocas em caixa plástica

Comp.: 8 brocas
Código: MTBE03

∅	UN
3,00	1
4,00	1
5,00	1
6,00	1
8,00	1
9,00	1
10,00	1
12,00	1

19,45 €

Comp.: 4 brocas
Código: MTBE04

∅	UN
5,00	1
6,00	1
8,00	1
10,00	1

9,02 €

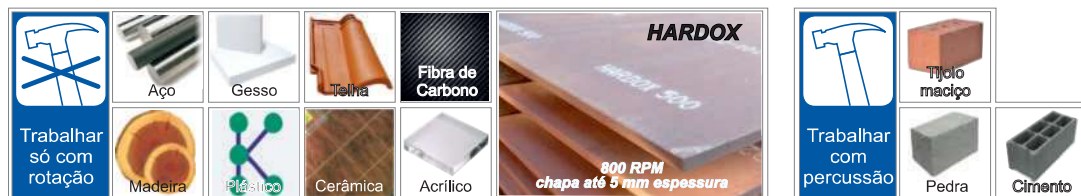
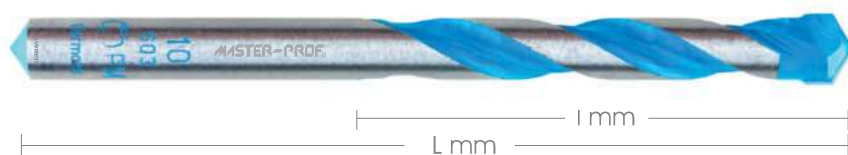

Código	∅	l mm	L mm	PCS	€
MTFT20	3,00	40	70	1	3,96
MTFT21	4,00	40	75	1	3,96
MTFT22	5,00	50	85	1	4,17
MTFT23	5,00	90	150	1	6,01
MTFT24	5,50	50	85	1	4,60
MTFT25	6,00	60	100	1	4,67
MTFT26	6,00	90	150	1	6,57
MTFT27	6,50	60	100	1	5,10
MTFT28	7,00	60	100	1	5,80
MTFT29	8,00	80	120	1	6,01
MTFT30	8,00	90	150	1	7,43
MTFT31	8,00	200	250	1	8,56
MTFT32	8,00	350	400	1	31,47
MTFT33	9,00	80	120	1	6,16
MTFT34	10,00	80	120	1	6,36
MTFT35	10,00	90	150	1	8,34
MTFT36	10,00	200	250	1	11,11
MTFT37	10,00	350	400	1	32,53
MTFT38	11,00	90	150	1	9,55
MTFT39	12,00	90	150	1	14,42
MTFT40	12,00	200	250	1	12,23
MTFT41	12,00	350	400	1	32,32
MTFT42	14,00	150	200	1	13,08
MTFT43	14,00	200	250	1	13,44
MTFT44	16,00	150	200	1	21,92



Comp.: 4 brocas
Código: MTF197

∅	UN
4,00	1
5,00	1
6,00	1
8,00	1

18,20 €



Comp.: 5 brocas
Código: MTF198

∅	UN
4,00	1
5,00	1
6,00	1
8,00	1
10,00	1

23,92 €



Comp.: 7 brocas
Código: MTF199

∅	UN
3,00	1
4,00	1
5,00	1
6,00	1
8,00	1
9,00	1
10,00	1

34,58 €

Características:

- Placa em metal duro, afiada e rectificada com geometria inovadora. A cabeça da placa garante uma centragem perfeita.
- Corpo da ferramenta em liga de aço.
- Hélice inovadora com ângulo acentuado.

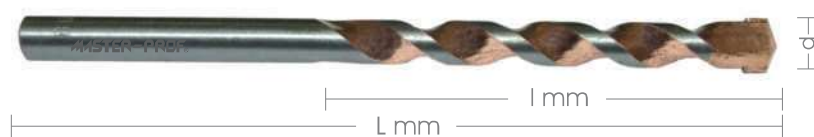

Código	∅	d	l mm	L mm	PCS	€
MTG001	3,00	2,80	30	60	1	1,00
MTG002	4,00	3,80	40	75	1	1,21
MTG003	5,00	4,50	50	75	1	1,52
MTG004	6,00	5,50	60	100	1	2,15
MTG005	7,00	6,50	60	100	1	2,67
MTG006	8,00	7,50	80	120	1	3,14
MTG007	9,00	8,00	80	120	1	3,83
MTG008	10,00	9,00	80	120	1	4,35
MTG009	11,00	10,00	90	150	1	5,24
MTG010	12,00	10,00	90	150	1	5,88
MTG011	13,00	10,00	90	150	1	7,34
MTG012	14,00	10,00	90	150	1	7,55
MTG013	15,00	10,00	100	160	1	8,38
MTG014	16,00	10,00	100	160	1	9,64
MTG015	18,00	10,00	100	160	1	11,79
MTG016	20,00	13,00	100	160	1	15,93

Código	∅	d	l mm	L mm	PCS	€
MTG100	5,00	4,50	90	150	1	10,71
MTG101	6,00	5,50	90	150	1	12,73
MTG102	8,00	7,50	90	150	1	15,45
MTG103	10,00	9,00	90	150	1	16,60

Prazo de entrega sujeito a confirmação

Código	∅	d	l mm	L mm	PCS	€
MTG200	8,00	7,50	200	250	1	17,06
MTG201	10,00	9,00	200	250	1	18,90
MTG202	12,00	10,00	200	250	1	23,85
MTG203	14,00	10,00	200	250	1	28,95

Prazo de entrega sujeito a confirmação

Jogos de brocas em caixa plástica



Comp.:4 brocas
Cód.:MTG300

∅	UNDS
5,00	1
6,00	1
8,00	1
10,00	1

13,89 €

Comp.:7 brocas
Cód.:MTG301

∅	UNDS
3,00	1
4,00	1
5,00	1
6,00	1
8,00	1
9,00	1
10,00	1

19,91 €



Código	∅	d	l mm	L mm	PCS	€
MTE001	3,00	2,80	30	70	1	2,32
MTE002	4,00	3,80	40	75	1	3,09
MTE003	5,00	4,50	50	85	1	3,87
MTE004	6,00	5,50	60	100	1	4,63
MTE005	7,00	6,50	60	100	1	5,41
MTE006	8,00	7,50	80	120	1	6,18
MTE007	10,00	9,00	80	120	1	7,72
MTE008	12,00	10,00	90	150	1	9,27
MTE009	14,00	10,00	200	250	1	10,82



Jogos de brocas caixa plástica

Comp.:4 brocas	
Cód.:MTE050	
∅	UN
5,00	1
6,00	1
8,00	1
10,00	1
22,40 €	

Corte preciso e rápido em rotação, em materiais muito duros e abrasivos

Brocas para vidro c/ponta em metal duro



Código	∅	d	L mm	PCS	€
MTV001	3,00	3,00	58	1	4,30
MTV002	4,00	3,00	58	1	4,30
MTV003	5,00	4,00	58	1	4,66
MTV004	6,00	5,00	58	1	4,66
MTV005	7,00	5,00	78	1	4,82
MTV006	8,00	6,00	78	1	4,82
MTV007	9,00	6,00	98	1	5,18
MTV008	10,00	7,00	98	1	5,18
MTV009	12,00	8,00	98	1	6,25



Código	Ød mm	Ød1 mm	l mm	L mm	PCS	€
MBSO70	1,00 x	3,15	1,60	31,50	1	4,28
MBSO71	1,25 x	3,15	1,90	33,50	1	4,28
MBSO72	1,60 x	4,00	2,40	37,50	1	4,28
MBSO73	2,00 x	5,00	2,90	42,00	1	4,62
MBSO74	2,50 x	6,30	3,60	47,00	1	5,11
MBSO75	3,15 x	8,00	4,40	52,00	1	5,65
MBSO76	4,00 x	10,00	5,60	56,00	1	8,16
MBSO77	5,00 x	12,50	6,90	66,00	1	13,66
MBSO78	6,30 x	16,00	8,60	74,00	1	19,56
MBSO79	10,00 x	25,00	13,70	100,00	1	56,51
MBSO80	1,25 x	4,00	1,90	35,50	1	4,54
MBSO81	1,60 x	5,00	2,40	40,00	1	4,54
MBSO82	2,00 x	6,30	2,90	45,00	1	4,97
MBSO83	2,50 x	8,00	3,60	50,00	1	5,65
MBSO84	3,15 x	10,00	4,40	56,00	1	6,64
MBSO85	4,00 x	12,50	5,60	63,00	1	9,07
MBSO86	5,00 x	16,00	6,90	71,00	1	21,74
MBSO87	6,30 x	20,00	8,60	80,00	1	33,19

HSS-CO DIN1897



Código	∅	l mm	L mm	PCS	€
MBSO46	6,00	66	6,00	1	11,50
MBSO47	7,00	74	7,00	1	12,94
MBSO48	8,00	79	8,00	1	13,68
MBSO49	10,00	89	10,00	1	17,41

HSS-CO / 1412E



Código	∅	l mm	d	PCS	€
MBSO50	6,50	40	6,50	1	13,38
MBSO51	8,00	40	8,00	1	15,23
MBSO52	8,00 VARIO	44	8,00	1	15,23

HSS-CO + TIN / 1412E



Código	∅	l mm	d	PCS	€
MBSO53	6,50	40	6,50	1	16,47
MBSO54	8,00	40	8,00	1	19,27
MBSO55	8,00 VARIO	44	8,00	1	19,27



Código	∅	d∅	L mm	PCS	€
MKB01	5,00	9,50	56	1	17,73
MKB02	6,00	9,50	56	1	17,73
MKB03	7,00	9,50	56	1	17,73
MKB04	8,00	9,50	56	1	17,73
MKB05	10,00	9,50	56	1	19,58
MKB06	12,00	9,50	56	1	22,95
MKB07	14,00	9,50	56	1	31,42

Código	∅	d∅	L mm	PCS	€
MKB08	16,00	12,50	90	1	42,76
MKB09	18,00	12,50	90	1	42,76
MKB10	20,00	12,50	90	1	46,48
MKB11	22,00	12,50	90	1	51,13
MKB12	25,00	12,50	90	1	57,17
MKB13	28,00	12,50	90	1	63,20
MKB14	30,00	12,50	90	1	67,86
MKB15	32,00	12,50	90	1	69,71
MKB16	35,00	12,50	90	1	81,81
MKB17	40,00	12,50	90	1	92,02
MKB18	45,00	12,50	90	1	103,17
MKB19	50,00	12,50	90	1	113,40
MKB20	60,00	12,50	90	1	133,85
MKB21	65,00	12,50	90	1	144,08
MKB22	80,00	12,50	90	1	175,68



Diametro da fresa em mm	5 a 7	8 a 10	12 a 14	16 a 25	28 a 35	40 a 50	60 a 80
Velocidade R. P. M.	1000	800	500	400	260	170	120

Exemplo de utilização da broca



Jogo brocas caixa plástica

Comp.: 5 brocas
Cód.: MKB50

∅	UN
5,00	1
6,00	1
8,00	1
10,00	1
12,00	1

95,73 €



Vitrine

Composição: 13 brocas
Código: MKB60

1 peça de cada
∅ 6, 8, 10, 12, 14, 16
18, 20, 25, 30, 35, 40, 50

OFERTA VITRINE

653,67 €

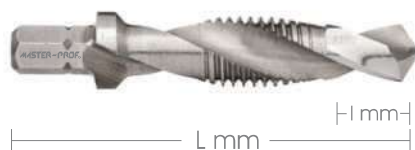

Código	∅	l mm	L mm	∅	PCS	€
MTX100	3 x 0,50	2,50	36	1/4	1	8,28
MTX101	4 x 0,70	3,30	39	1/4	1	8,28
MTX102	5 x 0,80	4,20	41	1/4	1	8,28
MTX103	6 x 1,00	5,00	44	1/4	1	8,28
MTX104	8 x 1,25	6,80	50	1/4	1	9,44
MTX105	10 x 1,50	8,50	59	1/4	1	9,44



58,49 €

Jogo de brocas em caixa plástica

Código ∅ Medida

MTX201 M3-M4-M5-M6-M8-M10

1 Desandador magnético 1/4

Broca com cabo hexagonal 1/4" para máquinas portáteis em HSS-G



Código	∅	l mm	L mm	∅	PCS	€
MTX001	1,00	7	32	1/4	1	5,10
MTX002	1,50	10	32	1/4	1	5,10
MTX003	2,00	12	34	1/4	1	5,10
MTX004	2,50 (M3)	14	36	1/4	1	5,10
MTX005	3,00	16	38	1/4	1	5,10
MTX006	3,30 (M4)	18	40	1/4	1	5,10
MTX007	3,50	18	40	1/4	1	5,10
MTX008	4,00	20	44	1/4	1	5,10
MTX009	4,20 (M5)	20	45	1/4	1	5,10
MTX010	4,50	24	46	1/4	1	5,10
MTX011	5,00 (M6)	26	50	1/4	1	5,10
MTX012	5,50	26	50	1/4	1	5,29
MTX013	6,00	26	50	1/4	1	5,29
MTX014	6,50	30	50	1/4	1	5,29
MTX015	6,80 (M8)	30	50	1/4	1	5,29
MTX016	7,00	30	50	1/4	1	5,29
MTX017	7,50	32	51	1/4	1	6,23
MTX018	8,00	32	51	1/4	1	6,23
MTX019	8,50 (M10)	33	53	1/4	1	7,12
MTX020	9,00	33	53	1/4	1	7,12
MTX021	9,50	38	54	1/4	1	8,01
MTX022	10,00	38	54	1/4	1	8,01
MTX023	10,20 (M12)	38	54	1/4	1	8,01



78,42 €

Jogo de brocas em caixa plástica

Código ∅ Medida

MTX200 1-10,5 x 0,5 (19 brocas)

Cabo "SDS Plus"



Código	∅	L1	L2	PCS	€
BLSDS04	8,00	235	160	1	8,55
BLSDS05	10,00	235	160	1	9,00
BLSDS07	12,00	235	160	1	9,66
BLSDS09	14,00	235	160	1	10,99
BLSDS11	16,00	235	160	1	12,19
BLSDS12	18,00	235	160	1	14,49
BLSDS14	20,00	235	160	1	16,44
BLSDS15	22,00	235	160	1	18,37
BLSDS16	24,00	235	160	1	20,14

Cabo Hexagonal



Código	∅	L1	L2	PCS	€
BLM01	6,00	235	160	1	7,28
BLM04	8,00	235	160	1	7,68
BLM05	10,00	235	160	1	8,11
BLM07	12,00	235	160	1	9,34
BLM09	14,00	235	160	1	10,60
BLM11	16,00	235	160	1	11,41
BLM12	18,00	235	160	1	13,05
BLM14	20,00	235	160	1	14,81
BLM15	22,00	235	160	1	16,54
BLM16	24,00	235	160	1	18,13



Código	∅	D1 Hex	Lmm	PCS	€
BPM01	6,00	6,35	150	1	1,65
BPM02	8,00	6,35	150	1	1,65
BPM03	9,00	6,35	150	1	1,66
BPM04	10,00	6,35	150	1	1,68
BPM05	11,00	6,35	150	1	1,68
BPM06	12,00	6,35	150	1	1,68
BPM07	13,00	6,35	150	1	1,78
BPM08	14,00	6,35	150	1	1,78
BPM09	15,00	6,35	150	1	1,83
BPM10	16,00	6,35	150	1	1,70
BPM26	17,00	6,35	150	1	1,70
BPM11	18,00	6,35	150	1	1,72
BPM12	19,00	6,35	150	1	1,74
BPM13	20,00	6,35	150	1	1,74
BPM27	21,00	6,35	150	1	1,83
BPM14	22,00	6,35	150	1	1,83
BPM28	23,00	6,35	150	1	1,83
BPM15	24,00	6,35	150	1	1,83
BPM16	25,00	6,35	150	1	1,97
BPM17	26,00	6,35	160	1	1,96
BPM29	27,00	6,35	160	1	2,20
BPM18	28,00	6,35	160	1	2,20
BPM30	29,00	6,35	160	1	2,34
BPM19	30,00	6,35	160	1	2,34
BPM20	32,00	6,35	160	1	2,58
BPM21	34,00	6,35	160	1	2,89
BPM22	35,00	6,35	160	1	2,89
BPM23	36,00	6,35	160	1	3,87
BPM24	38,00	6,35	160	1	3,94
BPM25	40,00	6,35	160	1	4,09



Jogo brocas

Comp.: 6 brocas
Cód.: BPMJ01

∅	PCS
10,00	1
12,00	1
16,00	1
18,00	1
20,00	1
25,00	1

13,79 €

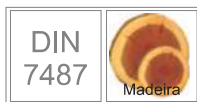

Código	∅	D1	L1mm	L2mm	PCS	€
BPG30	3,00	3	60	33	1	0,51
BPG31	4,00	4	75	43	1	0,58
BPG32	5,00	5	85	52	1	0,60
BPG33	6,00	6	93	57	1	0,74
BPG34	7,00	7	109	69	1	0,86
BPG35	8,00	8	117	75	1	0,77
BPG36	9,00	9	125	81	1	0,86
BPG37	10,00	10	133	87	1	1,00
BPG38	11,00	10	142	94	1	1,46
BPG39	12,00	10	151	101	1	1,50
BPG40	13,00	10	151	101	1	2,03
BPG41	14,00	10	160	108	1	2,25
BPG42	15,00	10	169	114	1	2,67
BPG43	16,00	10	178	120	1	2,84
BPG44	18,00	10	191	130	1	4,80
BPG45	20,00	10	205	140	1	5,87
BPG46	22,00	13	210	140	1	9,19
BPG47	24,00	13	215	140	1	10,77
BPG48	26,00	13	215	140	1	12,84
BPG49	28,00	13	220	140	1	15,15
BPG50	30,00	13	220	140	1	18,03

Brocas tipo Forstner (em metal duro)



Código	∅	D1	L1 mm	PCS	€
BFM02	15,00	10	90	1	20,33
BFM08	16,00	10	90	1	20,33
BFM09	19,00	10	90	1	20,33
BFM03	20,00	10	90	1	21,81
BFM10	22,00	10	90	1	21,81
BFM11	23,00	10	90	1	21,81
BFM04	25,00	10	90	1	23,24
BFM05	26,00	10	90	1	25,80
BFM06	30,00	10	90	1	26,16
BFM07	35,00	10	90	1	27,60



Adaptador de bits 1/4 Magnético

ADAPTADOR DE BITS 1/4" TX



Código	Ø mm	L mm	PCS	€ unidade
BM0760	8	50	5	3,58
BM0761	10	50	5	3,58
BM0762	8	65	5	6,36
BM0763	10	65	5	6,36
BM0764	7	50	5	3,58
BM0765	12	45	5	3,58



Hexagonal

PONTA DE 1/4" HEXAGONAL



Código	Ø	L mm	PCS	€ unidade
BM0001	1,5	25	10	0,58
BM0002	2	25	10	0,58
BM0003	2,5	25	10	0,58
BM0004	3	25	10	0,58
BM0005	4	25	10	0,58
BM0006	5	25	10	0,58
BM0007	6	25	10	0,58
BM0008	7	25	10	1,14
BM0009	8	25	10	1,14
BM0010	10	25	10	1,14



PH Fresado

PONTA DE 1/4" PHILLIPS

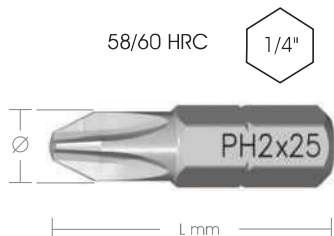

Código	+	Ø mm	L mm	PCS	€ unidade
BM0101	PH0	3	25	10	0,43
BM0102	PH1	4,5	25	10	0,43
BM0103	PH2	6	25	10	0,43
BM0104	PH3	6	25	10	0,43
BM0106	PH4	10	32	10	1,46



PH Fresado Longo

PONTA DE 1/4" PHILLIPS LONGO

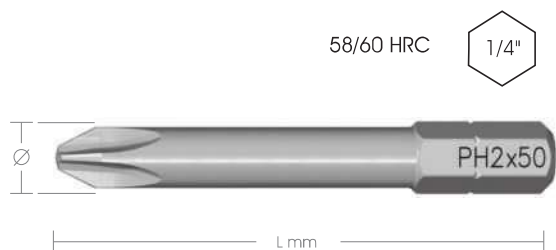

Código	+	Ø mm	L mm	PCS	€ unidade
BM0120	PH1	4,5	50	5	0,80
BM0121	PH2	6	50	5	0,80
BM0122	PH3	8	50	5	0,80



PH Fresado Longo e Extra Longo

PONTA DE 1/4" PHILLIPS LONGO E EXTRA LONGO

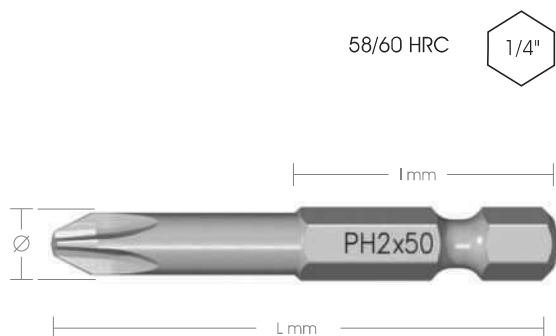

Código	+	Ø mm	L mm	l mm	PCS	€ unidade
BM0500	PH0	3	50	25	5	0,80
BM0501	PH0	3	75	25	5	1,60
BM0502	PH0	3	100	25	5	2,23
BM0503	PH1	4,5	50	25	5	0,80
BM0504	PH1	4,5	70	25	5	1,77
BM0505	PH1	4,5	75	25	5	1,73
BM0506	PH1	4,5	90	25	5	1,97
BM0507	PH1	4,5	100	25	5	2,14
BM0508	PH1	4,5	127	25	5	2,91
BM0509	PH1	4,5	150	25	5	3,86
BM0510	PH1	4,5	200	25	5	5,35
BM0511	PH2	6	50	25	5	0,80
BM0512	PH2	6	70	25	5	1,60
BM0513	PH2	6	75	25	5	1,73
BM0514	PH2	6	90	25	5	1,97
BM0515	PH2	6	100	25	5	2,14
BM0516	PH2	6	120	25	5	2,80
BM0517	PH2	6	127	25	5	2,91
BM0518	PH2	6	150	25	5	3,92
BM0519	PH2	6	200	25	5	5,35
BM0520	PH3	6	50	25	5	0,80
BM0521	PH3	8	50	25	5	1,19
BM0522	PH3	6	75	25	5	1,73
BM0523	PH3	8	75	25	5	2,53
BM0524	PH3	6	100	25	5	2,14
BM0525	PH3	8	100	25	5	3,27
BM0526	PH3	8	150	25	5	5,89
BM0527	PH4	10	50	25	5	2,02

 PH Torção +

PONTA DE 1/4" PHILLIPS - EXTRA DURO, RESISTENTE A ELEVADA TORÇÃO

60/62 HRC 





Código		L mm	PCS 	€ unidade
BM0183	PH1	25	10	1,01
BM0184	PH2	25	10	1,01
BM0185	PH3	25	10	1,01

 PH Torção + Longo

PONTA DE 1/4" PHILLIPS LONGO - EXTRA DURO, RESISTENTE A ELEVADA TORÇÃO

60/62 HRC 



Código		L mm	PCS 	€ unidade
BM0186	PH1	50	5	1,90
BM0187	PH2	50	5	1,90
BM0188	PH3	50	5	1,90

 PH Torção TM

PONTA DE 1/4" PHILLIPS - TENAZES RESISTENTES A ELEVADA TORÇÃO

58/60 HRC 





Código		L mm	PCS 	€ unidade
BM0170	PH1	25	10	0,53
BM0171	PH2	25	10	0,53
BM0172	PH3	25	10	0,53

 PH Torção TM Longo

PONTA DE 1/4" PHILLIPS LONGO - TENAZES RESISTENTES A ELEVADA TORÇÃO

58/60 HRC 



Código		L mm	PCS 	€ unidade
BM0176	PH1	50	5	1,25
BM0177	PH2	50	5	1,25
BM0178	PH3	50	5	1,25



PH Titânio

PONTA DE 1/4" PHILLIPS - REVESTIDA A TITÂNIO

59/60 HRC

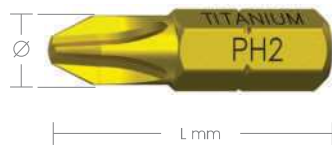

Código	+	Ø mm	L mm	PCS	€ unidade
BM0180	PH1	4,5	25	10	1,25
BM0181	PH2	4,5	25	10	1,25
BM0179	PH2	6	25	10	1,25
BM0182	PH3	6	25	10	1,25



PH Titânio Longo

PONTA DE 1/4" PHILLIPS LONGO - REVESTIDA A TITÂNIO

59/60 HRC

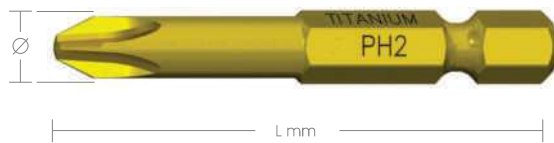

Código	+	Ø mm	L mm	PCS	€ unidade
BM0190	PH1	4,5	50	5	2,26
BM0191	PH2	6	50	5	2,26
BM0192	PH3	6	50	5	2,26



PH Impacto

PONTA DE 1/4" PHILLIPS LONGO - PARA MÁQUINAS DE IMPACTO

58/60 HRC



Código	+	L mm	PCS	€ unidade
BM0600	PH1	30	10	1,60
BM0601	PH2	30	10	1,60
BM0602	PH3	30	10	1,60



PH Impacto Longo

PONTA DE 1/4" PHILLIPS LONGO - PARA MÁQUINAS DE IMPACTO

58/60 HRC

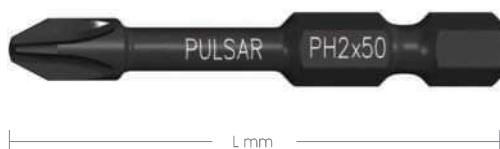

Código	+	L mm	PCS	€ unidade
BM0610	PH1	50	5	2,80
BM0611	PH2	50	5	2,80
BM0612	PH3	50	5	2,80



PH HDC

PONTA DE 1/4" PHILLIPS - REVESTIDA A DIAMANTE

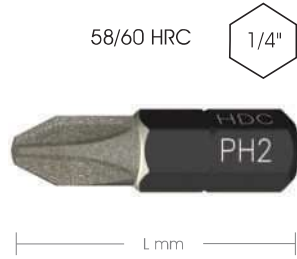

Código		L mm	PCS	€ unidade
BM0620	PH1	25	10	1,97
BM0621	PH2	25	10	1,97
BM0622	PH3	25	10	1,97



PH HDC Longo

PONTA DE 1/4" PHILLIPS LONGO - REVESTIDA A DIAMANTE



Código		L mm	PCS	€ unidade
BM0630	PH1	50	5	3,68
BM0631	PH2	50	5	3,68
BM0632	PH3	50	5	3,68



PZ Fresado

PONTA DE 1/4" POZIDRIV COM PONTA FRESADA



Código	+	Ø mm	L mm	PCS	€ unidade
BM0201	PZ0	3	25	10	0,43
BM0202	PZ1	4,5	25	10	0,43
BM0203	PZ2	6	25	10	0,43
BM0204	PZ3	6	25	10	0,43
BM0205	PZ4	10	32	10	1,46



PZ Fresado Longo

PONTA DE 1/4" POZIDRIV LONGO COM PONTA FRESADA

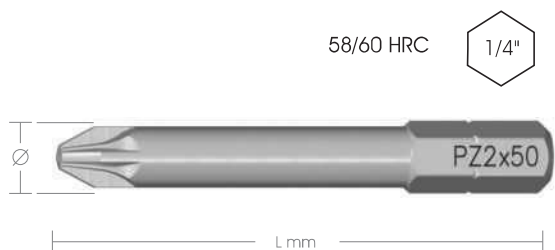

Código	+	Ø mm	L mm	PCS	€ unidade
BM0220	PZ1	4,5	50	5	0,80
BM0221	PZ2	6	50	5	0,80
BM0222	PZ3	8	50	5	0,80



PZ Fresado Longo e Extra Longo

PONTA DE 1/4" POZIDRIV LONGO E EXTRA LONGO COM PONTA FRESADA

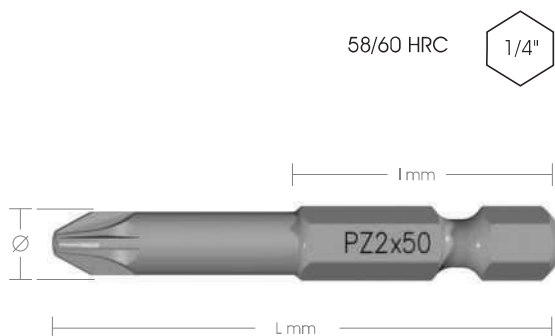

Código	+	Ø mm	L mm	l mm	PCS	€ unidade
BM0550	PZ0	3	50	25	5	0,80
BM0551	PZ1	4,5	50	25	5	0,80
BM0552	PZ1	4,5	70	25	5	1,60
BM0553	PZ1	4,5	75	25	5	1,73
BM0554	PZ1	4,5	90	25	5	1,97
BM0555	PZ1	4,5	100	25	5	2,14
BM0556	PZ1	4,5	127	25	5	2,91
BM0557	PZ1	4,5	150	25	5	3,92
BM0558	PZ1	4,5	200	25	5	5,35
BM0559	PZ2	6	50	25	5	0,80
BM0560	PZ2	6	70	25	5	1,60
BM0561	PZ2	6	75	25	5	1,73
BM0562	PZ2	6	90	25	5	1,97
BM0563	PZ2	6	100	25	5	2,14
BM0564	PZ2	6	127	25	5	2,91
BM0565	PZ2	6	150	25	5	3,92
BM0566	PZ2	6	200	25	5	5,35
BM0567	PZ3	6	50	25	5	0,80
BM0568	PZ3	8	50	25	5	1,19
BM0569	PZ3	6	75	25	5	1,73
BM0570	PZ3	8	75	25	5	2,53
BM0571	PZ3	6	100	25	5	2,14
BM0572	PZ3	8	100	25	5	3,27
BM0573	PZ3	8	150	25	5	5,89
BM0574	PZ4	10	50	25	5	2,02



PZ Torção +

PONTA DE 1/4" POZIDRIV - EXTRA DURO, RESISTENTE A ELEVADA TORÇÃO

60/62 HRC



Código		L mm	PCS	€ unidade
BM0293	PZ1	25	10	1,01
BM0294	PZ2	25	10	1,01
BM0295	PZ3	25	10	1,01



PZ Torção + Longo

PONTA DE 1/4" POZIDRIV LONGO - EXTRA DURO, RESISTENTE A ELEVADA TORÇÃO

60/62 HRC



Código		L mm	PCS	€ unidade
BM0296	PZ1	50	5	1,90
BM0297	PZ2	50	5	1,90
BM0298	PZ3	50	5	1,90



PZ Torção TM

PONTA DE 1/4" POZIDRIV - TENAZES RESISTENTES A ELEVADA TORÇÃO

58/60 HRC



Código		L mm	PCS	€ unidade
BM0270	PZ1	25	10	0,53
BM0271	PZ2	25	10	0,53
BM0272	PZ3	25	10	0,53



PZ Torção TM Longo

PONTA DE 1/4" POZIDRIV LONGO - TENAZES RESISTENTES A ELEVADA TORÇÃO

58/60 HRC



Código		L mm	PCS	€ unidade
BM0280	PZ1	50	5	1,25
BM0281	PZ2	50	5	1,25
BM0283	PZ3	50	5	1,25



PZ Titânio

PONTA DE 1/4" POZIDRIV - REVESTIDA A TITÂNIO

59/60 HRC

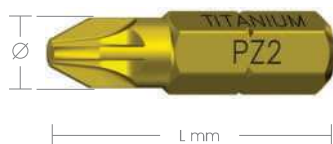

Código	+	Ø mm	L mm	PCS	€ unidade
BM0287	PZ1	4,5	25	10	1,25
BM0286	PZ2	6	25	10	1,25
BM0289	PZ3	6	25	10	1,25



PZ Titânio Longo

PONTA DE 1/4" POZIDRIV LONGO - REVESTIDA A TITÂNIO

59/60 HRC

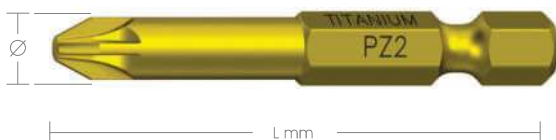

Código	+	Ø mm	L mm	PCS	€ unidade
BM0196	PZ2	6	50	5	2,26



PZ Impacto

PONTA DE 1/4" POZIDRIV LONGO - PARA MÁQUINAS DE IMPACTO

58/60 HRC



Código	+	L mm	PCS	€ unidade
BM0640	PZ1	30	10	1,60
BM0641	PZ2	30	10	1,60
BM0642	PZ3	30	10	1,60



PZ Impacto Longo

PONTA DE 1/4" POZIDRIV LONGO - PARA MÁQUINAS DE IMPACTO

58/60 HRC



Código	+	L mm	PCS	€ unidade
BM0650	PZ1	50	5	2,80
BM0651	PZ2	50	5	2,80
BM0652	PZ3	50	5	2,80



PZ HDC

PONTA DE 1/4" POZIDRIV - REVISTIDA A DIAMANTE

58/60 HRC

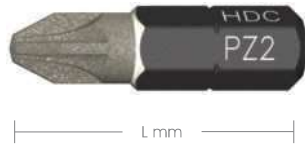

Código		L mm	PCS	€ unidade
BM0660	PZ1	25	10	1,97
BM0661	PZ2	25	10	1,97
BM0662	PZ3	25	10	1,97



PZ HDC Longo

PONTA DE 1/4" POZIDRIV LONGO - REVISTIDA A DIAMANTE

58/60 HRC

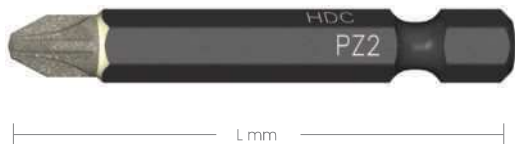

Código		L mm	PCS	€ unidade
BM0670	PZ1	50	5	3,68
BM0671	PZ2	50	5	3,68
BM0672	PZ3	50	5	3,68



TX

PONTA DE 1/4" PARA PARAFUSOS TORX

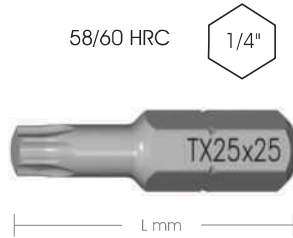

Código		L mm	PCS	€ unidade
BM1000	TX06	25	10	0,53
BM1001	TX07	25	10	0,53
BM1002	TX08	25	10	0,53
BM1003	TX09	25	10	0,53
BM1004	TX10	25	10	0,53
BM1005	TX15	25	10	0,53
BM1006	TX20	25	10	0,53
BM1007	TX25	25	10	0,53
BM1008	TX27	25	10	0,53
BM1009	TX30	25	10	0,53
BM1010	TX40	25	10	0,53
BM1011	TX45	25	10	1,07
BM1012	TX50	25	10	1,34



TX Longo e Extra Longo

PONTA DE 1/4" LONGO E EXTRA LONGO PARA PARAFUSOS TORX

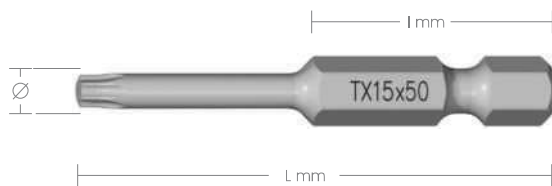

58/60 HRC



Código		Ø mm	L mm	lmm	PCS	€ unidade
BM1100	TX05	3	50	25	5	3,39
BM1101	TX06	3	50	25	5	3,39
BM1102	TX06	3	70	25	5	2,91
BM1103	TX06	3	100	25	5	3,84
BM1104	TX06	3	150	25	5	7,73
BM1105	TX07	3	50	25	5	3,39
BM1106	TX07	3	70	25	5	2,91
BM1107	TX08	3	50	25	5	3,39
BM1108	TX08	3	70	25	5	2,91
BM1109	TX08	3	100	25	5	3,84
BM1110	TX08	3	150	25	5	7,73
BM1111	TX09	3	50	25	5	3,39
BM1112	TX10	4	50	25	5	0,95
BM1113	TX10	4	70	25	5	1,73
BM1114	TX10	4	90	25	5	3,82
BM1115	TX10	4	100	25	5	3,98
BM1116	TX10	4	127	25	5	5,41
BM1117	TX10	4	150	25	5	8,62
BM1118	TX10	5	200	25	5	10,64
BM1119	TX15	4	50	25	5	0,95
BM1120	TX15	4	70	25	5	1,73
BM1121	TX15	4	90	25	5	3,82
BM1122	TX15	4	100	25	5	3,98
BM1123	TX15	4	127	25	5	5,41
BM1124	TX15	4	150	25	5	8,62
BM1125	TX15	5	200	25	5	10,64

Código		Ø mm	L mm	lmm	PCS	€ unidade
BM1126	TX20	4,5	50	25	5	0,95
BM1127	TX20	5	70	25	5	1,73
BM1128	TX20	5	90	25	5	3,82
BM1129	TX20	5	100	25	5	3,98
BM1130	TX20	5	127	25	5	5,41
BM1131	TX20	5	150	25	5	8,62
BM1132	TX20	5	200	25	5	10,64
BM1134	TX25	5	50	25	5	0,95
BM1135	TX25	5	70	25	5	1,73
BM1136	TX25	5	90	25	5	3,82
BM1137	TX25	5	100	25	5	3,98
BM1138	TX25	5	127	25	5	5,41
BM1139	TX25	5	150	25	5	8,62
BM1140	TX25	5	200	25	5	10,64
BM1141	TX27	6	50	25	5	0,95
BM1142	TX27	6	70	25	5	1,73
BM1143	TX27	6	90	25	5	3,82
BM1144	TX27	6	100	25	5	3,98
BM1145	TX27	6	127	25	5	5,41
BM1146	TX30	6	50	25	5	0,95
BM1147	TX30	6	70	25	5	1,73
BM1148	TX30	6	90	25	5	3,82
BM1149	TX30	6	100	25	5	3,98
BM1150	TX30	6	127	25	5	5,41
BM1151	TX30	6	150	25	5	8,29
BM1152	TX40	1/4	50	25	5	0,95
BM1153	TX40	1/4	70	25	5	1,73
BM1154	TX40	1/4	90	25	5	3,82
BM1155	TX40	1/4	100	25	5	3,98
BM1156	TX40	1/4	150	25	5	8,62



TX Torção TM

PONTA DE 1/4" PARA PARAFUSOS TORX - TENAZES RESISTENTES A ELEVADA TORÇÃO



Código		L mm	PCS	€ unidade
BM1020	TX10	25	10	0,72
BM1021	TX15	25	10	0,72
BM1022	TX20	25	10	0,72
BM1023	TX25	25	10	0,72
BM1024	TX27	25	10	0,72
BM1025	TX30	25	10	0,72
BM1026	TX40	25	10	0,72



TX Torção TM Longo

PONTA DE 1/4" PARA PARAFUSOS TORX LONGO - TENAZES RESISTENTES A ELEVADA TORÇÃO



Código		L mm	PCS	€ unidade
BM1030	TX10	50	5	2,56
BM1031	TX15	50	5	2,56
BM1032	TX20	50	5	2,56
BM1033	TX25	50	5	2,56
BM1034	TX27	50	5	2,56
BM1035	TX30	50	5	2,56
BM1036	TX40	50	5	2,56



TX Titânio

PONTA DE 1/4" PARA PARAFUSOS TORX - REVESTIDA A TITÂNIO



Código		L mm	PCS	€ unidade
BM1050	TX10	25	10	1,55
BM1051	TX15	25	10	1,55
BM1052	TX20	25	10	1,55
BM1053	TX25	25	10	1,55
BM1054	TX27	25	10	1,55
BM1055	TX30	25	10	1,55
BM1056	TX40	25	10	1,55



TX Impacto

PONTA DE 1/4" PARA PARAFUSOS TORX PARA MÁQUINAS DE IMPACTO

58/60 HRC



L mm

Código		L mm	PCS	€ unidade
BM1060	TX10	30	10	2,03
BM1061	TX15	30	10	2,03
BM1062	TX20	30	10	2,03
BM1063	TX25	30	10	2,03
BM1064	TX27	30	10	2,03
BM1065	TX30	30	10	2,03
BM1066	TX40	30	10	2,03



TX Impacto Longo

PONTA DE 1/4" PARA PARAFUSOS TORX LONGO PARA MÁQUINAS DE IMPACTO

58/60 HRC



L mm

Código		L mm	PCS	€ unidade
BM1070	TX10	50	5	3,87
BM1071	TX15	50	5	3,87
BM1072	TX20	50	5	3,87
BM1073	TX25	50	5	3,87
BM1074	TX27	50	5	3,87
BM1075	TX30	50	5	3,87
BM1076	TX40	50	5	3,87



TX HDC

PONTA DE 1/4" PARA PARAFUSOS TORX - REVISTIDA A DIAMANTE

58/60 HRC



L mm

Código		L mm	PCS	€ unidade
BM1080	TX10	25	10	2,85
BM1081	TX15	25	10	2,85
BM1082	TX20	25	10	2,85
BM1083	TX25	25	10	2,85
BM1084	TX30	25	10	2,85
BM1085	TX40	25	10	2,85



Fenda

PONTA DE 1/4" DE FENDA

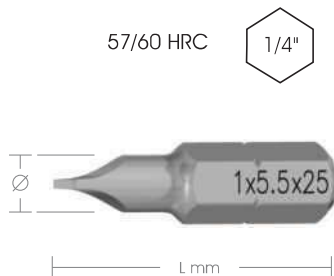

Código	Ø mm	L mm	PCS	€ unidade	
BM1200	0,5	3	25	10	0,58
BM1201	0,6	3,5	25	10	0,58
BM1202	0,6	4	25	10	0,58
BM1203	0,6	4,5	25	10	0,58
BM1204	0,8	5	25	10	0,58
BM1205	0,8	5,5	25	10	0,58
BM1206	1	5,5	25	10	0,58
BM1207	1	6	25	10	0,58
BM1208	1,2	6,5	25	10	0,58
BM1209	1,2	8	25	10	1,04
BM1210	1,6	8	25	10	1,04



Fenda Longa e Extra Longa

PONTA DE 1/4" LONGA E EXTRA LONGA DE FENDA

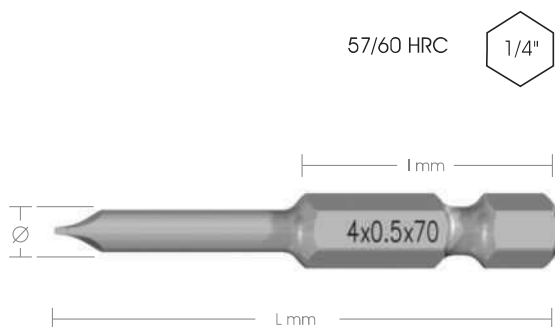

Código	Ø mm	L mm	lmm	PCS	€ unidade	
BM1250	0,5	3	50	25	5	0,98
BM1251	0,5	3	70	25	5	1,73
BM1252	0,6	3,5	50	25	5	0,98
BM1253	0,6	3,5	70	25	5	1,73
BM1254	0,5	4	50	25	5	0,98
BM1255	0,5	4	70	25	5	1,73
BM1256	0,5	4	100	25	5	3,81
BM1257	0,6	4,5	50	25	5	0,98
BM1258	0,6	4,5	70	25	5	1,73
BM1259	0,6	4,5	100	25	5	3,81
BM1260	0,8	5	50	25	5	0,98
BM1261	0,8	5	70	25	5	1,73
BM1262	0,8	5	100	25	5	3,81
BM1263	0,8	5,5	50	25	5	0,98
BM1264	0,8	5,5	70	25	5	1,73
BM1265	1	6	50	25	5	0,98
BM1266	1	6	70	25	5	1,73
BM1267	1	6	100	25	5	3,81
BM1268	1,2	6,5	50	25	5	0,98
BM1269	1,2	6,5	70	25	5	1,73
BM1270	1,2	8	50	25	5	1,31
BM1271	1,2	8	70	25	5	2,08



Fenda Titânio

PONTA DE 1/4" DE FENDA REVESTIDA A TITÂNIO



Código	Ø mm	L mm	PCS	€ unidade	
BM1290	0,5	3	25	10	1,52
BM1291	0,6	4	25	10	1,52
BM1292	0,6	4,5	25	10	1,52
BM1293	0,8	5,5	25	10	1,52
BM1294	1,2	6,5	25	10	1,52



Adaptador Quick Lock

ADAPTADOR MAGNÉTICO DE 1/4" COM SISTEMA DE BLOQUEIO

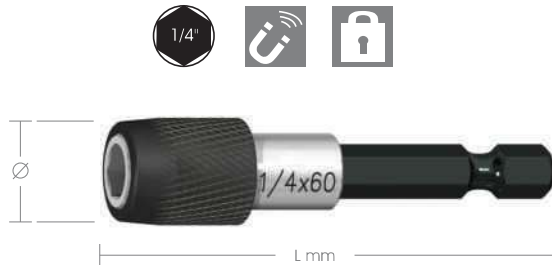

Código	Ømm	L mm	PCS	€ unidade
BM2000	14	60	5	6,83
BM2001	14	75	5	8,62
BM2002	14	100	5	17,68
BM2003	14	120	5	17,83
BM2004	14	150	5	18,72
BM2005	14	200	5	19,61
BM2006	14	250	5	20,74



Adaptador Magnético Standard (sem anel)

ADAPTADOR MAGNÉTICO DE 1/4" SEM ANEL



Código	Ømm	L mm	PCS	€ unidade
BM2020	10	50	5	3,33
BM2021	10	60	5	3,39
BM2022	10	75	5	4,07
BM2023	10	100	5	7,07
BM2024	10	120	5	9,57
BM2025	10	150	5	9,98
BM2026	10	200	5	11,23
BM2027	10	250	5	18,30



Adaptador Magnético Standard (com anel)

ADAPTADOR MAGNÉTICO DE 1/4" COM ANEL



Código	Ømm	L mm	PCS	€ unidade
BM2040	10	50	5	4,16
BM2041	10	60	5	4,31
BM2042	10	75	5	4,82
BM2043	10	100	5	7,28
BM2044	9,8	120	5	9,98
BM2045	10	150	5	10,49
BM2046	9,8	200	5	11,65
BM2047	11	250	5	18,72
BM2048	11	400	5	20,80



Adaptador Magnético Industrial Reforçado

ADAPTADOR MAGNÉTICO COM ANEL CORPO REFORÇADO



Código	Ømm	L mm	PCS	€ unidade
BM2061	11	60	5	4,75
BM2062	11	75	5	4,93



COMPOSIÇÃO

7 PCS



PH1 **PH2**
1 pc 1 pc



PZ1 **PZ2**
1 pc 1 pc



0,6x4,5 **1,2x6,5**
1 pc 1 pc



Bitbox7
Fresado

CÓDIGO: BM0720

10,10 €

Bitbox7
Torção

CÓDIGO: BM0721

11,47 €

Bitbox7
Torção Extra

CÓDIGO: BM0722

13,07 €

Bitbox7
Titânio

CÓDIGO: BM0723

15,22 €

Bitbox7
Impacto

CÓDIGO: BM0724

17,47 €

Bitbox7
Diamante

CÓDIGO: BM0725

23,54 €



COMPOSIÇÃO

7 PCS



PH1 **PH2**
1 pc 1 pc



PZ1 **PZ2**
1 pc 1 pc



5,5 **6,5**
1 pc 1 pc



CÓDIGO: BM0702

























6,20 €



CÓDIGO: BM0706

22,51 €

Bitbox 26































COMPOSIÇÃO			26 PCS						
 PH1 1 pc	 PH2 2 pcs	 PH3 1 pc	 PZ1 1 pc	 PZ2 2 pcs	 PZ3 1 pc	 3 1 pc	 4 1 pc	 5,5 1 pc	 6,5 1 pc
 Adaptador 1/4 C a 1/4 C 1 pc			 TX10 1 pc	 TX15 1 pc	 TX20 1 pc	 CH5 1 pc			
			 TX25 1 pc	 TX30 1 pc	 CH6 1 pc				
						 CH7 1 pc			
						 CH8 1 pc			
						 CH10 1 pc			
						 CH13 1 pc			
			 1x Chave			 1x Adaptador Magnético			



CÓDIGO: BM0701

18,57 €

Bitbox 32







COMPOSIÇÃO			32 PCS					
 HEX3 1 pc	 HEX4 1 pc	 HEX5 1 pc	 TX10 1 pc	 TX15 1 pc	 TX20 1 pc	 TX10 1 pc	 TX15 1 pc	 TX20 1 pc
 HEX6 1 pc			 TX25 1 pc	 TX27 1 pc	 TX30 1 pc	 TX25 1 pc	 TX27 1 pc	 TX30 1 pc
			 TX40 1 pc			 TX40 1 pc		
 3 1 pc	 4 1 pc			 PH1 1 pc	 PH2 1 pc	 PH3 1 pc	 PZ1 1 pc	 PZ2 1 pc
 5 1 pc	 6 1 pc						 PZ3 1 pc	
			 1x Adaptador Quick Look			 1x mini adaptador		



COMPOSIÇÃO: 590 PCS
CÓDIGO: BM0730

600 x 90 x 65 mm

474,18 €

 PH0 25mm 4 caixas de 10 peças PH1 25MM 4 caixas de 10 peças PH2 25mm 4 caixas de 10 peças PH3 25MM 4 caixas de 10 peças  5 Adaptadores Quick Lock 1/4 60mm	PH1 50mm 3 caixas de 5 peças PH2 50MM 3 caixas de 5 peças PH3 50mm 3 caixas de 5 peças PZ1 25mm 4 caixas de 10 peças PZ2 25MM 4 caixas de 10 peças PZ3 25mm 4 caixas de 10 peças PZ1 50mm 3 caixas de 5 peças PZ2 50MM 3 caixas de 5 peças	 PZ1 25mm 4 caixas de 10 peças PZ2 25MM 4 caixas de 10 peças PZ3 25mm 4 caixas de 10 peças PZ1 50mm 3 caixas de 5 peças PZ2 50MM 3 caixas de 5 peças	 TX15 25mm 3 caixas de 10 peças TX20 25MM 3 caixas de 10 peças TX25 25mm 3 caixas de 10 peças TX30 25MM 3 caixas de 10 peças TX40 25mm 3 caixas de 10 peças	 HEX4 25mm 2 caixas de 10 peças HEX5 25MM 2 caixas de 10 peças HEX6 25mm 2 caixas de 10 peças  1,2x6,5 25MM 2 caixas de 10 peças
---	---	---	--	---



NOVO ARTIGO

COMPOSIÇÃO: 606 PCS
CÓDIGO: BM0731

954,98 €

 PH2 25mm 5 caixas de 10 peças BM0103 PH2 50mm 6 caixas de 5 peças BM0511 PH2 100mm 6 caixas de 5 peças BM0515 PH2 TIN 25mm 3 caixas de 10 peças BM0181 PH2 Extra Duro 25mm 3 caixas de 10 peças BM0184 PH2 Torção 25mm 3 caixas de 10 peças BM0171	 PH2 50MM 6 caixas de 5 peças BM0121 PH2 90MM 6 caixas de 5 peças BM0514 PH2 150MM 6 caixas de 5 peças BM0518 PH2 TIN 50mm 4 caixas de 5 peças BM0191 PH2 Extra Duro 50mm 4 caixas de 5 peças BM0187	 PZ1 25mm 5 caixas de 10 peças BM0202 PZ2 TIN 25mm 3 caixas de 10 peças BM0286 PZ1 Extra Duro 25mm 3 caixas de 10 peças BM0293  BITBOX 32 2 jogo de bits 30 bits + 2 adaptadores BM0701	 PZ2 25MM 5 caixas de 10 peças BM0203 PZ3 TIN 25MM 3 caixas de 10 peças BM0289 PZ2 Extra Duro 25MM 3 caixas de 10 peças BM0294  BITBOX 7 5 jogos de bits 6 bits + 1 adaptador BM0702	 Adaptador Magnético Standard S/anel 50mm 10 caixas de 1 peça BM02020 60mm 10 caixas de 1 peça BM02021 75mm 10 caixas de 1 peça BM02022	 Adaptador Magnético Standard C/anel 50mm 5 caixas de 1 peça BM02040 60mm 5 caixas de 1 peça BM02041 75mm 5 caixas de 1 peça BM02042
---	--	--	---	---	--



Cone DIN238

Código	Capacidade	Cone	PCS	€
MACC013	1 - 10	B 12	1	13,90
MACC015	1 - 13	B 16	1	13,90
MACC012	3 - 16	B 16	1	13,90
MACC014	3 - 16	B 18	1	13,90
MACC016	5 - 20	B 22	1	28,26



Rosca interior

Código	Capacidade	R/UNF	PCS	€
MACC017	1,5 - 10	1/2 x 20	1	9,43
MACC018	1,5 - 10	3/8 x 24	1	9,43
MACC019	1,5 - 13	1/2 x 20	1	13,90
MACC020	1,5 - 13	3/8 x 24	1	13,90

Buchas de aperto rápido tipo standard para berbequins portáteis



Cone DIN238

Código	Capacidade	Cone	PCS	€
MAAR001	0,5 - 6	B 10	1	35,95
MAAR002	1 - 10	B 12	1	35,95
MAAR003	1 - 13	B 16	1	34,08
MAAR004	3 - 16	B 16	1	45,75
MAAR005	3 - 16	B 18	1	45,75



Rosca Interior

Código	Capacidade	R/UNF	PCS	€
MAAR006	0,5 - 6	3/8 x 24	1	29,41
MAAR007	1 - 10	3/8 x 24	1	29,41
MAAR011	1 - 10	1/2 x 20	1	29,41
MAAR008	1 - 13	1/2 x 20	1	34,08
MAAR012	1 - 13	3/8 x 24	1	34,08
MAAR009	3 - 16	1/2 x 20	1	44,72
MAAR010	3 - 16	5/8 x 16	1	44,72

Buchas de aperto rápido de precisão para berbequins fixos e portáteis



Profissionais - Rosca Interior

Código	Capacidade	R/UNF	PCS	€
MAAR015	1 - 13	1/2 x 20	1	58,50
MAAR016	1 - 13	3/8 x 24	1	58,50

Até fim de existências



Profissionais - Cone DIN238

Código	Capacidade	Cone	PCS	€
MAAR013	1 - 16	B 16	1	66,30
MAAR014	1 - 16	B 18	1	66,30

Buchas sem chave
para berbequins portáteis profissionais

Código	Capacidade	R/UNF	PCS	€
MACP011	0,8 - 10	1/2 x 20	1	20,08
MACP012	0,8 - 10	3/8 x 24	1	20,08
MACP013	2 - 13	1/2 x 20	1	25,68
MACP014	2 - 13	3/8 x 24	1	25,68

Caixa plástica



Buchas de aperto com sistema de segurança

Código	Capacidade	R/UNF	PCS	€
MACP017	2 - 13	1/2 x 20	1	28,25
MACP018	2 - 13	3/8 x 24	1	28,25

Caixa plástica



Acessórios para buchas

Chaves

Código	Medida	D	PCS	€
MACH030	S1	4 mm	1	1,36
MACH031	S2-R	6 mm	1	1,78
MACH032	S2	6 mm	1	2,85
MACH033	S3	8 mm	1	3,06
MACH034	S4	9 mm	1	3,90



Adaptadores

Código	Capacidade	PCS	€
MAAB010	SDS 1/2 x 20 UNF	1	7,50





Buchas com chave - Cone DIN238

Código	Capacidade	Cone	PCS	€
MAECO001	1 - 13	B 16	1	7,48
MAECO002	3 - 16	B 16	1	11,38
MAECO003	3 - 16	B 18	1	13,16



Buchas com chave - Rosca Interior

Código	Capacidade	R/UNF	PCS	€
MAECO100	1,5 - 10	1/2 x 20	1	3,56
MAECO101	1,5 - 10	3/8 x 24	1	3,56
MAECO102	1,5 - 13	1/2 x 20	1	4,80
MAECO103	1,5 - 13	3/8 x 24	1	4,80



Buchas de aperto rápido - Cone DIN238

Código	Capacidade	Cone	PCS	€
MAECO200	1 - 13	B 16	1	25,26
MAECO201	3 - 16	B 16	1	28,93
MAECO202	3 - 16	B 18	1	28,93



Buchas de aperto rápido - Rosca Interior

Código	Capacidade	R/UNF	PCS	€
MAECO300	1 - 10	3/8 x 24	1	23,15
MAECO301	1 - 10	1/2 x 20	1	23,15
MAECO302	1 - 13	1/2 x 20	1	23,54
MAECO303	1 - 13	3/8 x 24	1	23,54



Buchas sem chave para berbequins portáteis profissionais em caixa plástica

Código	Capacidade	R/UNF	PCS	€
MAECO400	0,8 - 10	1/2 x 20	1	5,98
MAECO401	0,8 - 10	3/8 x 24	1	5,98
MAECO402	2 - 13	1/2 x 20	1	7,51
MAECO403	2 - 13	3/8 x 24	1	7,51



Buchas sem chave de aperto rápido com sistema de segurança em caixa plástica

Código	Capacidade	R/UNF	PCS	€
MAECO500	2 - 13	1/2 x 20	1	15,45
MAECO501	2 - 13	3/8 x 24	1	15,45

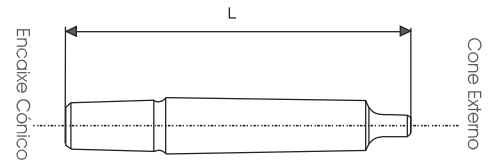
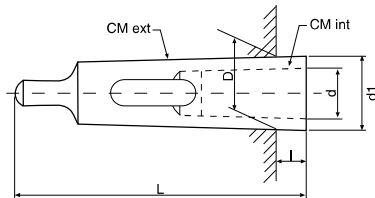

Cones de redução DIN2185

Código	Cone Morse Ext. / Int.	L mm	l mm	D mm	d mm	d1 mm	PCS	€
MER001	2 - 1	92	17,00	17,78	12,065	18,60	1	6,40
MER002	3 - 1	99	5,00	23,825	12,065	24,10	1	9,98
MER003	3 - 2	112	18,00	23,825	17,780	24,70	1	9,20
MER004	4 - 1	124	6,50	31,267	12,065	31,60	1	15,44
MER005	4 - 2	124	6,50	31,267	17,780	31,60	1	14,35
MER006	4 - 3	140	22,50	31,267	23,825	32,40	1	13,88
MER012	5 - 1	156	6,50	44,399	12,065	44,70	1	30,73
MER007	5 - 2	156	6,50	44,399	17,780	44,70	1	30,73
MER008	5 - 3	156	6,50	44,399	23,825	44,70	1	31,67
MER009	5 - 4	171	21,50	44,399	31,267	45,50	1	30,11
MER010	6 - 4	218	8,00	63,340	31,760	63,80	1	70,36
MER011	6 - 5	218	8,00	63,340	44,706	63,80	1	68,17

Encabadouros para buchas DIN228/238

Código	Cone Morse	Encaixe Cônico	L	PCS	€
MEB20	CM1	B 10	86	1	6,20
MEB21	CM1	B 12	89	1	6,20
MEB22	CM1	B 16	99	1	6,20
MEB33	CM2	B 10	105	1	7,80
MEB23	CM2	B 12	105	1	7,80
MEB24	CM2	B 16	112	1	5,30
MEB25	CM2	B 18	119	1	5,62
MEB34	CM2	B 22	130	1	7,80
MEB26	CM3	B 12	127	1	7,02
MEB27	CM3	B 16	134	1	6,86
MEB28	CM3	B 18	140	1	7,33
MEB29	CM3	B 22	147	1	7,33
MEB30	CM4	B 16	157	1	15,44
MEB31	CM4	B 18	164	1	15,76
MEB32	CM4	B 22	176	1	16,69
MEB35	CM5	B 16	198	1	33,54
MEB36	CM5	B 18	198	1	34,79
MEB37	CM5	B 22	207	1	36,19
MEB38	CM5	B 24	217	1	37,75

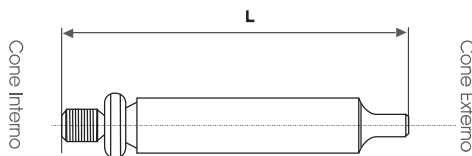

Encabadouros roscados DIN228

Código	Cone Morse	R/UNF	L	PCS	€
MEB80	CM2	3/8 x 24	95	1	15,74
MEB81	CM2	1/2 x 20	110	1	15,74
MEB82	CM2	5/8 x 16	135	1	19,55
MEB83	CM3	3/8 x 24	115	1	21,63
MEB84	CM3	1/2 x 20	125	1	21,63
MEB85	CM3	5/8 x 16	150	1	21,63



Buris redondos
Forma A - DIN4964 - H8 10° CO

Código	dmm - Lmm	PCS	€
MY0001	3 x 100	1	5,78
MY0002	3 x 150	1	8,83
MY0003	4 x 80	1	5,91
MY0004	4 x 100	1	6,05
MY0005	4 x 150	1	9,12
MY0006	4 x 200	1	12,21
MY0007	5 x 80	1	6,56
MY0008	5 x 100	1	8,21
MY0009	5 x 150	1	10,82
MY0010	5 x 200	1	12,14
MY0011	6 x 80	1	7,61
MY0012	6 x 100	1	9,56
MY0013	6 x 150	1	11,26
MY0014	6 x 200	1	14,58
MY0078	7 x 200	1	18,88
MY0015	8 x 100	1	10,54
MY0016	8 x 150	1	15,58
MY0017	8 x 200	1	19,62
MY0018	10 x 100	1	13,55
MY0019	10 x 150	1	20,19
MY0020	10 x 200	1	24,41
MY0021	12 x 100	1	17,09
MY0022	12 x 150	1	24,92
MY0023	12 x 200	1	29,74
MY0035	14 x 100	1	22,80
MY0024	14 x 150	1	39,34
MY0025	14 x 200	1	39,34
MY0036	16 x 100	1	30,25
MY0026	16 x 150	1	40,36
MY0027	16 x 200	1	53,92
MY0037	16 x 250	1	70,32
MY0028	18 x 150	1	59,84
MY0029	18 x 200	1	59,84
MY0030	20 x 150	1	75,48
MY0031	20 x 200	1	75,48
MY0038	22 x 200	1	94,89
MY0032	25 x 150	1	107,65
MY0033	25 x 200	1	107,65
MY0034	30 x 200	1	155,08

Buris quadrados
Forma B - DIN4964 - 10° CO

Código	bmm - Bmm - Lmm	PCS	€
MY0039	4 x 4 x 80	1	7,15
MY0040	4 x 4 x 100	1	8,48
MY0041	4 x 4 x 150	1	12,02
MY0042	4 x 4 x 200	1	14,66
MY0043	5 x 5 x 80	1	6,89
MY0044	5 x 5 x 100	1	8,36
MY0045	5 x 5 x 150	1	11,39
MY0046	5 x 5 x 200	1	13,95
MY0047	6 x 6 x 80	1	6,04
MY0048	6 x 6 x 100	1	6,89
MY0049	6 x 6 x 150	1	9,46
MY0050	6 x 6 x 200	1	11,51
MY0051	8 x 8 x 100	1	11,75
MY0052	8 x 8 x 150	1	15,65
MY0053	8 x 8 x 200	1	19,17
MY0054	10 x 10 x 100	1	16,75
MY0055	10 x 10 x 150	1	21,93
MY0056	10 x 10 x 200	1	30,32
MY0057	12 x 12 x 100	1	20,49
MY0058	12 x 12 x 150	1	28,50
MY0059	12 x 12 x 200	1	37,09
MY0060	14 x 14 x 100	1	25,83
MY0074	14 x 14 x 150	1	33,80
MY0061	14 x 14 x 200	1	45,12
MY0062	16 x 16 x 150	1	43,64
MY0063	16 x 16 x 200	1	54,95
MY0073	16 x 16 x 250	1	69,50
MY0064	18 x 18 x 150	1	52,99
MY0065	18 x 18 x 200	1	70,36
MY0066	20 x 20 x 150	1	65,37
MY0067	20 x 20 x 200	1	85,86
MY0068	25 x 25 x 150	1	90,62
MY0069	25 x 25 x 200	1	118,75
MY0070	30 x 30 x 200	1	290,33
MY0071	32 x 32 x 200	1	296,65
MY0072	35 x 35 x 200	1	312,87
MY0075	35 x 35 x 250	1	386,79

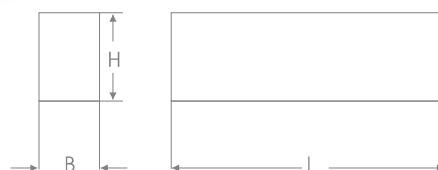
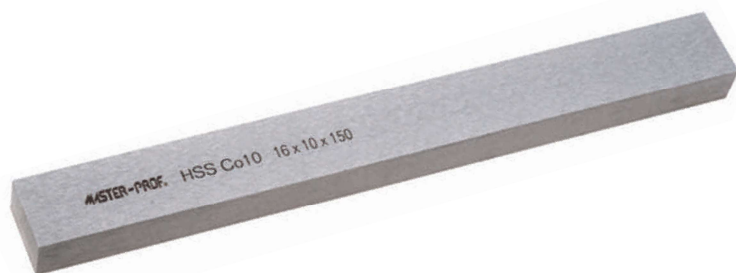

Código	Bmm - Hmm - Lmm	PCS	€
MY0080	8 x 4 x 160	1	15,52
MY0081	8 x 4 x 200	1	19,40
MY0082	8 x 6 x 150	1	33,78
MY0083	8 x 6 x 200	1	31,70
MY0138	10 x 3 x 200	1	19,91
MY0084	10 x 6 x 150	1	18,01
MY0085	10 x 6 x 200	1	22,92
MY0086	10 x 8 x 160	1	32,01
MY0087	10 x 8 x 200	1	41,00
MY0139	12 x 3 x 200	1	19,66
MY0088	12 x 6 x 150	1	18,83
MY0089	12 x 6 x 200	1	29,24
MY0090	12 x 8 x 150	1	29,49
MY0091	12 x 8 x 200	1	29,49
MY0092	12 x 10 x 150	1	38,48
MY0093	12 x 10 x 200	1	48,25
MY0094	14 x 8 x 200	1	54,55
MY0095	14 x 10 x 160	1	53,01
MY0096	14 x 10 x 200	1	53,01
MY0097	14 x 12 x 160	1	57,40
MY0098	14 x 12 x 200	1	57,40
MY0099	15 x 10 x 200	1	73,16
MY0100	16 x 8 x 150	1	38,97
MY0101	16 x 8 x 200	1	38,97
MY0102	16 x 10 x 150	1	33,09
MY0103	16 x 10 x 200	1	41,00
MY0104	16 x 12 x 150	1	46,41
MY0105	16 x 12 x 200	1	48,94
MY0106	18 x 6 x 160	1	35,99
MY0107	18 x 6 x 200	1	35,99
MY0144	18 x 10 x 200	1	67,49

Código	Bmm - Hmm - Lmm	PCS	€
MY0137	20 x 5 x 150	1	28,38
MY0108	20 x 8 x 150	1	43,09
MY0109	20 x 8 x 200	1	59,16
MY0110	20 x 10 x 150	1	59,22
MY0111	20 x 10 x 200	1	59,22
MY0112	20 x 12 x 150	1	62,44
MY0113	20 x 12 x 200	1	62,44
MY0114	20 x 16 x 150	1	70,32
MY0115	20 x 16 x 200	1	70,32
MY0116	25 x 10 x 150	1	73,19
MY0117	25 x 10 x 200	1	73,19
MY0118	25 x 12 x 150	1	64,48
MY0119	25 x 12 x 200	1	86,06
MY0120	25 x 16 x 160	1	91,56
MY0121	25 x 16 x 200	1	111,47
MY0122	25 x 20 x 160	1	85,80
MY0123	25 x 20 x 200	1	95,60
MY0141	30 x 10 x 200	1	78,29
MY0124	30 x 12 x 150	1	110,33
MY0125	30 x 12 x 200	1	110,33
MY0126	30 x 20 x 200	1	196,45
MY0127	32 x 16 x 160	1	137,03
MY0128	32 x 16 x 200	1	137,03
MY0132	35 x 12 x 200	1	119,82
MY0129	40 x 10 x 160	1	91,76
MY0130	40 x 10 x 200	1	111,94
MY0131	40 x 12 x 200	1	113,64
MY0133	45 x 12 x 200	1	205,34
MY0135	50 x 10 x 200	1	164,60
MY0134	50 x 12 x 200	1	227,34
MY0136	55 x 12 x 200	1	347,48

Buris redondos em Metal Duro K10



Código	ø mm - Lmm	PCS	€
MY0300	4 x 100	1	12,82
MY0301	6 x 100	1	24,71
MY0302	8 x 100	1	37,52
MY0303	10 x 100	1	52,62
MY0304	12 x 100	1	74,59
MY0305	14 x 100	1	100,21
MY0306	16 x 100	1	124,93
MY0307	18 x 100	1	152,38
MY0308	20 x 100	1	191,73

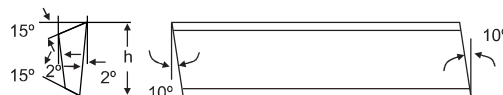
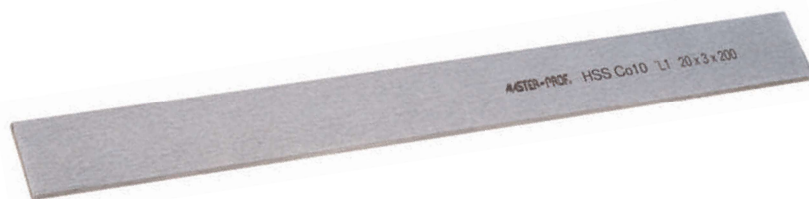

Lâminas Forma "E" - DIN4964 - H8 10° CO

Código	Hmm - Bmm - Lmm	PCS	€
MW001	12 x 3 x 100	1	10,19
MW002	12 x 3 x 160	1	15,42
MW003	12 x 3 x 200	1	22,58
MW004	12 x 5 x 100	1	16,28
MW005	12 x 5 x 160	1	22,70
MW006	12 x 5 x 200	1	36,71
MW007	16 x 4 x 100	1	20,49
MW008	16 x 4 x 160	1	24,22
MW009	16 x 4 x 200	1	32,62
MW010	18 x 3 x 100	1	15,62
MW011	18 x 3 x 160	1	25,56
MW012	18 x 3 x 200	1	31,59
MW013	18 x 4 x 100	1	21,33
MW014	18 x 4 x 150	1	25,71
MW015	18 x 4 x 200	1	34,29
MW016	18 x 6 x 100	1	22,13
MW017	18 x 6 x 160	1	46,52
MW018	18 x 6 x 200	1	43,43
MW019	20 x 3 x 100	1	16,57
MW020	20 x 3 x 150	1	25,93
MW021	20 x 3 x 200	1	33,06
MW022	20 x 4 x 100	1	27,75
MW023	20 x 4 x 160	1	27,75
MW024	20 x 4 x 200	1	34,68
MW025	20 x 5 x 100	1	34,14
MW026	20 x 5 x 160	1	31,92
MW027	20 x 5 x 200	1	44,78
MW200	22 x 4 x 120	1	45,06
MW028	25 x 6 x 100	1	56,93
MW029	25 x 6 x 160	1	60,54
MW030	25 x 6 x 200	1	73,16

Lâminas Forma "L1" 10° CO

Código	Hmm - Bmm - Lmm	PCS	€
MW059	10 x 3 x 200	1	25,22
MW034	12 x 3 x 120	1	12,84
MW035	12 x 3 x 160	1	17,00
MW107	12 x 3,5 x 200	1	47,30
MW036	12 x 4 x 120	1	28,73
MW037	12 x 4 x 160	1	28,73
MW038	12 x 5 x 120	1	27,75
MW039	12 x 5 x 160	1	33,97
MW100	15 x 3 x 100	1	27,87
MW106	15 x 3 x 200	1	27,87
MW040	16 x 3 x 120	1	25,40
MW041	16 x 3 x 160	1	26,71
MW108	16 x 3 x 200	1	33,40
MW042	16 x 4 x 120	1	31,76
MW043	16 x 4 x 160	1	31,76
MW044	16 x 6 x 120	1	45,10
MW045	16 x 6 x 160	1	45,10
MW110	16 x 8 x 200	1	59,91
MW101	17 x 3 x 125	1	25,22
MW102	17 x 3,5 x 125	1	28,38
MW201	18 x 3 x 120	1	41,00
MW109	18 x 3 x 200	1	28,67
MW103	18 x 3,5 x 125	1	56,75
MW046	18 x 4 x 120	1	31,31
MW047	18 x 4 x 160	1	31,31
MW057	18 x 4 x 200	1	47,30
MW048	19 x 3,5 x 125	1	21,62
MW203	20 x 3 x 100	1	22,92
MW049	20 x 3 x 125	1	21,62
MW050	20 x 3 x 160	1	28,57
MW056	20 x 3 x 200	1	34,68
MW032	20 x 3,5 x 125	1	26,33
MW051	20 x 4 x 120	1	22,39
MW052	20 x 4 x 160	1	28,55
MW058	20 x 4 x 200	1	37,08
MW033	20 x 5 x 160	1	41,47
MW202	20 x 5 x 200	1	70,32
MW104	22 x 3 x 120	1	23,69
MW111	25 x 3 x 120	1	30,91
MW112	25 x 4 x 125	1	29,96
MW053	25 x 4 x 150	1	37,84
MW054	25 x 6 x 120	1	34,49
MW055	25 x 6 x 160	1	63,38

Corte de ferro

Código	A x B x C	R.P.M. Velocidade Máxima	PCS	€
MD002	115 x 3 x 22	13000	50	0,99
MD003	125 x 3 x 22	12000	50	1,08
MD004	180 x 3,2 x 22	8500	25	1,46
MD005	230 x 3,2 x 22	6600	25	2,10
MD006	300 x 3,2 x 25,4	5000	25	3,95
MD008	300 x 3,2 x 30	5000	25	3,95
MD007	350 x 3,5 x 25,4	4000	10	6,38
MD009	350 x 3,5 x 30	4000	10	6,38

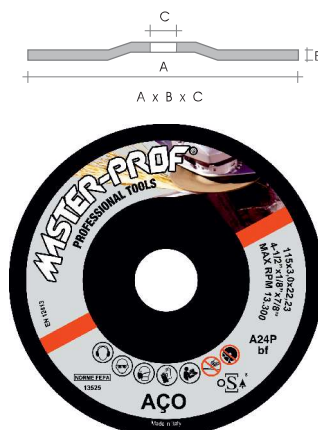

Corte de pedra

Código	A x B x C	R.P.M. Velocidade Máxima	PCS	€
MD011	115 x 3 x 22	13000	50	1,06
MD012	125 x 3 x 22	12000	50	1,16
MD013	180 x 3,2 x 22	8500	25	1,58
MD014	230 x 3,2 x 22	6600	25	2,34
MD015	300 x 3,2 x 25,4	5000	25	3,95
MD016	300 x 3,2 x 30	5000	25	3,95

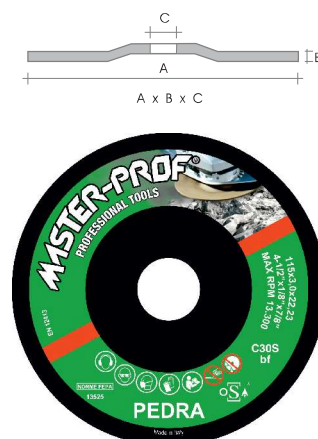

Rebarbar

Código	A x B x C	R.P.M. Velocidade Máxima	PCS	€
MD021	115 x 6 x 22	13000	50	1,37
MD022	125 x 6 x 22	12000	50	1,55
MD042	150 x 6 x 22	10000	50	1,91
MD023	180 x 7 x 22	8500	25	2,10
MD025	230 x 6 x 22	5000	25	3,30

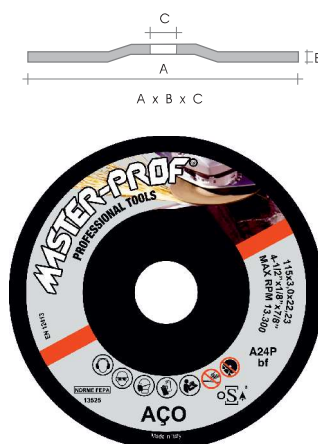

Corte de inox

Código	A x B x C	R.P.M. Velocidade Máxima	PCS	€
MD030	115 x 1 x 22	13000	50	1,06
MD031	115 x 1,6 x 22	13000	50	1,06
MD032	115 x 2 x 22	13000	50	1,16
MD033	115 x 3 x 22	13000	50	1,16
MD040	125 x 1 x 22	12000	50	1,20
MD043	125 x 1,2 x 22	12000	50	1,35
MD034	125 x 1,6 x 22	12000	50	1,29
MD035	125 x 3 x 22	12000	50	1,29
MD041	180 x 1,6 x 22	8500	50	1,76
MD036	180 x 2 x 22	8500	25	1,61
MD037	180 x 3 x 22	8500	25	1,66
MD038	230 x 2 x 22	6600	25	2,39
MD039	230 x 3 x 22	6600	25	2,43



Rebarbar inox

Código	A x B x C	R.P.M. Velocidade Máxima	PCS	€
MD050	115 x 6 x 22	13300	50	1,58
MD051	125 x 6 x 22	12250	50	1,75
MD052	180 x 7 x 22	8500	25	2,54
MD053	230 x 6 x 22	6650	25	4,06

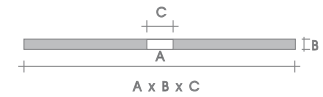

Disco compresso

Código	A x B x C	Grão	R.P.M. Velocidade Máxima	PCS	€
MD110 SL-2SF	115 x 12,5 x 22	2	11000	10	22,86
MD111 CA-3SF	115 x 12,5 x 22	3	11000	10	28,06

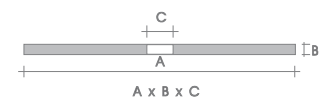

115 - SL Peças Lisas 115

115 - CA Peças com ângulo

Disco especial para rebarbar, polir, acabamento, remove imperfeições em todo o tipo de metais (inox, aço, titânio, alumínio, madeira e material plástico).

Polimento e rectificação da soldadura: os discos compressos para inox estão preparados para um excelente acabamento de superfícies e arranque de material, assim como peças angulares e ranhuras de difícil acesso.



Expositor de discos abrasivos em acrílico

Comp.: 1175 discos Cód.: MDJ001

Tipo de disco	Medida	Unidades
Corte de ferro	115 x 3	100
Corte de ferro	125 x 3	50
Corte de ferro	180 x 3,2	50
Corte de ferro	230 x 3,2	100
Corte de ferro	300 x 3,2	25
Corte de pedra	115 x 3	50
Corte de pedra	125 x 3	50
Corte de pedra	180 x 3	25
Corte de pedra	230 x 3	25
Rebarbar	115 x 6	100
Rebarbar	125 x 6	50
Rebarbar	180 x 7	100
Rebarbar	230 x 6	100
Corte de inox	115 x 1	200
Corte de inox	115 x 2	50
Corte de inox	125 x 1,6	50
Corte de inox	180 x 2	25
Corte de inox	230 x 2	25

Oferta do expositor

1.932,75 €

Master Line Zircónio - Linha Económica

Código	A x C	Grão	Vel. Máx. R.P.M.	PCS	€
MDLAM001	115 x 22	40	10500	10	2,52
MDLAM002	115 x 22	60	10500	10	2,52
MDLAM003	115 x 22	80	10500	10	2,52
MDLAM004	115 x 22	120	10500	10	2,52
MDLAM010	125 x 22	40	9650	10	3,00
MDLAM011	125 x 22	60	9650	10	3,00
MDLAM012	125 x 22	80	9650	10	3,00
MDLAM013	125 x 22	120	9650	10	3,00

Restantes medidas sob consulta

- * Ideal para aplicações em aço, madeira e metais não ferrosos.
- * Corte rápido e óptimo desempenho na remoção do material.

Master Top Line Zircónio - Gama Alta

Código	A x C	Grão	Vel. Máx. R.P.M.	PCS	€
MDLAM101	115 x 22	40	10500	10	3,34
MDLAM102	115 x 22	60	10500	10	3,34
MDLAM103	115 x 22	80	10500	10	3,34
MDLAM104	115 x 22	120	10500	10	3,34
MDLAM110	125 x 22	40	9650	10	3,60
MDLAM111	125 x 22	60	9650	10	3,60
MDLAM112	125 x 22	80	9650	10	3,60
MDLAM113	125 x 22	120	9650	10	3,60

Restantes medidas sob consulta

- * Produto versátil para retificar e desbastar em aço e inox.
- * Rendimento constante e duradouro.
- * Baixa vibração e ruído.

Master Cerâmico (Lâmina Dupla)

Código	A x C	Grão	Vel. Máx. R.P.M.	PCS	€
MDLAM201	115 x 22	40	10500	10	4,50
MDLAM202	115 x 22	60	10500	10	4,50
MDLAM210	125 x 22	40	9650	10	4,90
MDLAM211	125 x 22	60	9650	10	4,90



Restantes medidas sob consulta

- * Excelente desempenho em aços forjados e liga de aço.
- * Longa durabilidade.



Super económico



Código	Medida	Segmento Esp. / Alt.	Furo	PCS	€
MK100	115	2,1 x 7	22,2	1	7,07
MK101	125	2,1 x 7	22,2	1	8,47
MK102	180	2,4 x 7	22,2	1	15,29
MK103	230	2,6 x 8	22,2	1	20,43
MK104	300	3 x 8	25,4	1	34,40
MK105	350	3 x 8	25,4	1	52,42

Uso geral				Corte a seco	* Garantia de segurança * Máximo rendimento * Uma excelente relação qualidade / preço
-----------	---	---	---	--------------	---



Contínuo normal (flat core)



Código	Medida	Segmento Esp. / Alt.	Furo	PCS	€
MK146	115	2,1 x 7	22,2	1	8,20
MK147	125	2,1 x 7	22,2	1	9,01
MK148	180	2,4 x 7	22,2	1	15,10
MK149	230	2,6 x 8	22,2	1	22,88
MK150	300	3 x 8	25,4	1	52,15
MK151	350	3 x 8	25,4	1	57,61

Uso geral				Corte a seco	* Design do diamante melhorado para um rendimento superior
-----------	---	---	---	--------------	--



Turbo ondulado (waved core)





Código	Medida	Segmento Esp. / Alt.	Furo	PCS	€
MK162	115	2,1 x 7	22,2	1	20,97
MK163	125	2,1 x 7	22,2	1	28,08
MK164	180	2,4 x 7	22,2	1	43,68
MK165	230	2,6 x 8	22,2	1	49,80
MK166	300	3 x 8	25,4	1	130,58

Uso geral				Corte a seco	* Combinação perfeita entre o diamante e a ondulação do disco, o disco Kodia com maior reputação
-----------	---	---	---	--------------	--



Banda lisa

Código	Medida	Segmento Esp. / Alt.	Furo	PCS	€
Mk184	115	1 x 7	22,2	1	6,82
MK185	115	1,6 x 7	22,2	1	7,07
MK186	125	1,6 x 7	22,2	1	9,83
MK187	180	1,6 x 7	22,2	1	11,74
MK188	230	1,6 x 7	22,2	1	17,66
MK189	300	2 x 8	25,4	1	32,49
MK190	350	2,6 x 8	25,4	1	49,41

				Corte a húmido	* Disco profissional especial para corte de telha e cerâmica
---	---	---	---	----------------	--



Electrodepositados

Código	Medida	Segmento Esp. / Alt.	Furo	PCS	€
MK192	115	2,1 x 7	22,2	1	30,28
MK193	125	2,1 x 7	22,2	1	39,60
MK194	180	2,4 x 7	22,2	1	58,53
MK195	230	2,6 x 7	22,2	1	71,64

			Corte a seco	<ul style="list-style-type: none"> * Qualidade aprovada e garantida * Corte perfeito, não deixa rebarba
---	---	---	---------------------	---



Ultra super turbo (world top)





Código	Medida	Segmento Esp. / Alt.	Furo	PCS	€
MK340	115	2,6 x 10	22,2	1	24,92
MK341	125	2,6 x 10	22,2	1	31,08
MK342	180	3,1 x 10	22,2	1	49,28
MK343	200	3,1 x 10	22,2	1	53,48
MK344	230	3,1 x 10	22,2	1	54,88
MK345	300	3,1 x 10	22,2	1	101,08
MK346	350	3,1 x 10	25,4	1	109,48

		Corte a seco	<ul style="list-style-type: none"> * Alto rendimento e anti-vibração * Corte contínuo sem ser necessário a paragem do disco para arrefecimento
---	---	---------------------	--



Banda lisa turbo world top (especial para grês)

Código	Medida	Segmento Esp. / Alt.	Furo	PCS	€
MK330	115	1,2 x 7	22,2	1	23,05
MK331	125	1,2 x 7	22,2	1	24,08
MK332	150	1,4 x 7	22,2	1	31,36
MK333	180	1,4 x 7	22,2	1	36,68
MK334	200	1,6 x 8	22,2	1	39,20
MK335	230	1,6 x 8	22,2	1	45,22

					Corte a húmido	<ul style="list-style-type: none"> * Alto rendimento * Anti - vibração * Corte perfeito e silencioso
---	---	---	---	---	-----------------------	---



Laser asfalto (Premium)

Código	Medida	Segmento Esp. / Alt.	Furo	PCS 	€
MK196	300	2,8 x 7	25,4	1	98,55
MK197	350	2,8 x 7	25,4	1	100,05
MK198	400	3 x 7	25,4	1	128,03
MK199	450	3 x 7	25,4	1	154,13
MK200	500	3,6 x 7	25,4	1	177,73
MK201	600	3,6 x 7	25,4	1	300,57



Corte
a
húmido

* Especial asfalto e betão fresco
* Os segmentos soldados a laser garantem a máxima
segurança



Expositor em acrílico

Comp.: 60 discos
Código:MK300

Código	Diam.	Unds.
MK100	115	10
MK103	230	10
MK146	115	10
MK149	230	10
MK162	115	5
MK165	230	5
MK185	115	5
MK188	230	5

Oferta do expositor

1.063,30 €

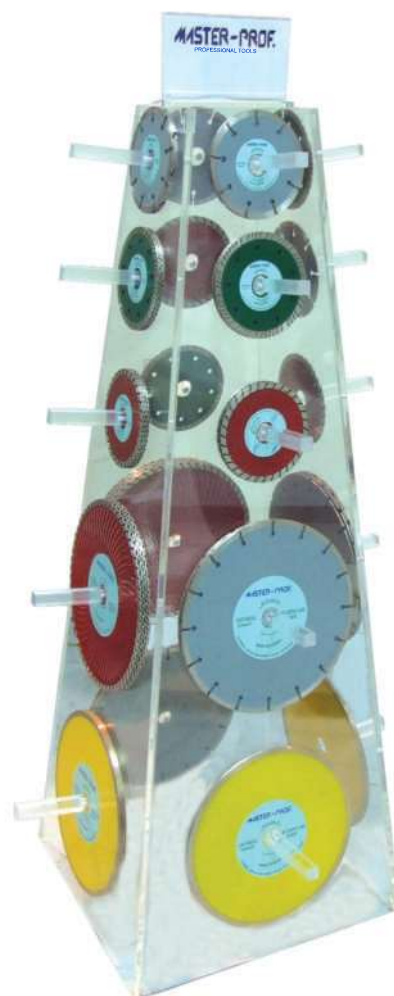

Coroas de rebaixar e mós tipo taça cónica para pedra



Para desbaste



Código	Medida	Segmento Esp. / Alt.	Rosca	PCS	€
MK182	100	8 X 22	M14	1	65,79

Peça integral	 Concreto	 Mármore	 Granito	Trabalha a seco	* Com corpo em alumínio * Anti-vibração
---------------	--	---	---	-----------------	--



Para acabamento

Código	Medida	Segmento Esp. / Alt.	Rosca	PCS	€
MK183	100	8 X 22	M14	1	65,79

Peça integral	 Concreto	 Mármore	 Granito	Trabalha a seco	* Com corpo em alumínio * Anti-vibração
---------------	--	---	---	-----------------	--



Mó tipo taça cónica para pedra (100x90x55) universal

Código	Grão	Rosca métrica	PCS	€
MD50	16	M 14 x 2	1	9,41
MD51	20	M 14 x 2	1	9,41
MD52	24	M 14 x 2	1	9,41
MD53	30	M 14 x 2	1	9,41
MD54	36	M 14 x 2	1	9,41
MD55	40	M 14 x 2	1	9,41
MD56	46	M 14 x 2	1	9,41
MD57	60	M 14 x 2	1	9,41
MD58	80	M 14 x 2	1	9,41
MD59	100	M 14 x 2	1	9,41
MD60	120	M 14 x 2	1	9,41
MD61	150	M 14 x 2	1	9,41
MD63	220	M 14 x 2	1	10,37



A	B	C	D
100	90	55	14

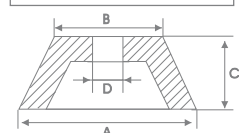

Escareadores de 3 canais, ângulo 90° em HSS-CO - DIN335C

Código	Ø Nominal	Capacidade Mínima / Máxima	Comp.	Cabo	PCS	€
ESCO01	4,30	1,30 - 4,00	40	4	1	7,77
ESCO02	5,30	1,50 - 4,80	40	4	1	7,77
ESCO03	6,30	1,50 - 5,80	45	5	1	8,02
ESCO04	7,30	1,80 - 6,80	50	6	1	8,88
ESCO05	8,30	2,00 - 7,80	50	6	1	9,09
ESCO06	9,40	2,20 - 8,90	50	6	1	9,96
ESCO07	10,40	3,00 - 9,70	50	6	1	10,95
ESCO08	12,40	3,20 - 12,00	56	8	1	11,82
ESCO09	15,00	3,50 - 15,00	60	10	1	13,56
ESCO10	16,50	3,60 - 16,00	60	10	1	14,47
ESCO15	19,00	3,50 - 19,00	63	10	1	16,91
ESCO11	20,50	3,50 - 20,00	63	10	1	19,92
ESCO16	23,00	3,80 - 23,00	67	10	1	21,81
ESCO12	25,00	4,50 - 24,00	67	10	1	30,59
ESCO13	28,00	4,00 - 27,50	71	12	1	35,40
ESCO14	31,00	5,00 - 30,00	71	12	1	38,68



Jogo em caixa metálica

Comp.: 6 UNDS
Código: ESJO01

Ø	UN
6,30	1
8,30	1
10,40	1
12,40	1
16,50	1
20,50	1

74,28 €

Escareadores de 3 canais, ângulo 90° em HSS-CO / Titânio - DIN335C

Código	Ø Nominal	Capacidade Mínima / Máxima	Comp.	Cabo	PCS	€
ESTI01	4,30	1,30 - 4,00	40	4	1	12,23
ESTI02	5,30	1,50 - 4,80	40	4	1	12,23
ESTI03	6,30	1,50 - 5,80	45	5	1	12,40
ESTI04	7,30	1,80 - 6,80	50	6	1	14,30
ESTI05	8,30	2,00 - 7,80	50	6	1	14,55
ESTI06	9,40	2,20 - 8,90	50	6	1	15,40
ESTI07	10,40	3,00 - 9,70	50	6	1	16,44
ESTI08	12,40	3,20 - 12,00	56	8	1	17,85
ESTI09	15,00	3,50 - 15,00	60	10	1	20,46
ESTI10	16,50	3,60 - 16,00	60	10	1	21,44
ESTI15	19,00	3,50 - 19,00	63	10	1	25,07
ESTI11	20,50	3,50 - 20,00	63	10	1	29,52
ESTI16	23,00	3,80 - 23,00	67	10	1	35,84
ESTI12	25,00	4,50 - 24,00	67	10	1	41,83
ESTI13	28,00	4,00 - 27,50	71	12	1	46,13
ESTI14	31,00	5,00 - 30,00	71	12	1	56,62



Jogo em caixa metálica

Comp.: 6 UNDS
Código: ESJT01

Ø	UN
6,30	1
8,30	1
10,40	1
12,40	1
16,50	1
20,50	1

112,21 €

Escareadores com furo, ângulo de 90° em HSS-CO

Código	Ø Exterior	Capacidade Mínima / Máxima	Comp.	Cabo	PCS	€
ESCF01	10,00	2,00 - 5,00	45	6	1	10,64
ESCF02	14,00	5,00 - 10,00	48	8	1	11,95
ESCF03	20,00	10,00 - 15,00	65	8	1	23,52
ESCF04	27,00	15,00 - 20,00	86	8	1	41,68
ESCF05	30,00	20,00 - 25,00	102	10	1	76,17
ESCF06	35,00	25,00 - 30,00	115	10	1	112,52
ESCF07	40,00	30,00 - 35,00	127	12	1	165,32
ESCF08	45,00	35,00 - 40,00	136	12	1	233,05
ESCF09	50,00	40,00 - 50,00	166	12	1	285,88



Jogo em caixa metálica

Comp.: 4 UNDS
Código: ESCFJ01

Ø	UN
2 - 5	1
5 - 10	1
10 - 15	1
15 - 20	1

87,80 €

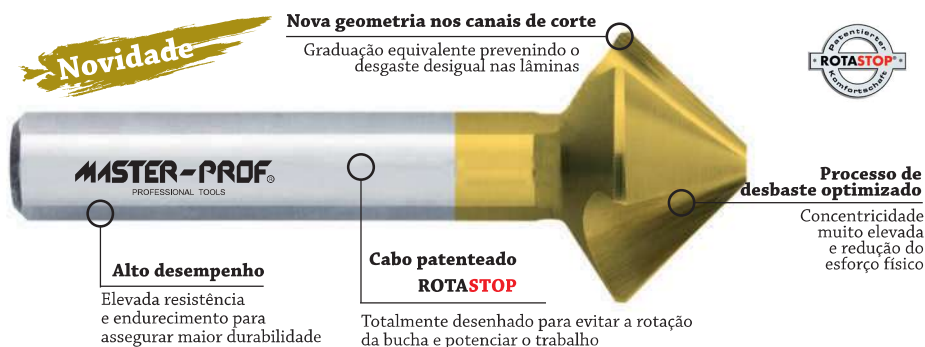

- + 50% de durabilidade
- + 25% de rapidez
- + facilidade na realização do trabalho
- + melhor acabamento



HSS-CO

Código							€
ESTOP50	6,30	45	5	1,5	M 3	1	14,17
ESTOP51	8,30	50	6	2,0	M 4	1	17,81
ESTOP52	10,40	50	6	2,5	M 5	1	18,41
ESTOP53	12,40	56	8	2,8	M 6	1	20,51
ESTOP54	15,00	60	10	3,2	M 8	1	26,85
ESTOP55	16,50	60	10	3,2	M 8	1	27,48
ESTOP56	19,00	63	10	3,5	M 10	1	29,02
ESTOP57	20,50	63	10	3,5	M 10	1	29,74
ESTOP58	23,00	67	10	3,8	M 12	1	31,19
ESTOP59	25,00	67	10	3,8	M 12	1	36,20
ESTOP60	31,00	71	12	4,2	M 16	1	40,29



HSS-TIN

Código							€
ESTOP01	6,30	45	5	1,5	M 3	1	15,46
ESTOP02	8,30	50	6	2,0	M 4	1	19,42
ESTOP03	10,40	50	6	2,5	M 5	1	20,08
ESTOP04	12,40	56	8	2,8	M 6	1	22,36
ESTOP05	15,00	60	10	3,2	M 8	1	29,28
ESTOP06	16,50	60	10	3,2	M 8	1	29,97
ESTOP07	19,00	63	10	3,5	M 10	1	31,64
ESTOP08	20,50	63	10	3,5	M 10	1	32,43
ESTOP09	23,00	67	10	3,8	M 12	1	34,01
ESTOP10	25,00	67	10	3,8	M 12	1	34,69
ESTOP11	31,00	71	12	4,2	M 16	1	37,39



Novidade

Jogo em HSS-CO - caixa plástica

Comp.: 6 UNDS
Código: ESTOP70

Ø	UN
6,30	1
8,30	1
10,40	1
12,40	1
16,50	1
20,50	1

128,12 €

Comp.: 5 UNDS
Código: ESTOP71

Ø	UN
6,30	1
10,40	1
16,50	1
20,50	1
25,00	1

123,16 €



Novidade

Jogo em HSS-TIN - caixa plástica

Comp.: 6 UNDS
Código: ESTOP30

Ø	UN
6,30	1
8,30	1
10,40	1
12,40	1
16,50	1
20,50	1

139,72 €

Comp.: 5 UNDS
Código: ESTOP31

Ø	UN
6,30	1
10,40	1
16,50	1
20,50	1
25,00	1

131,94 €

Com cabo patenteado **ROTASTOP**® DIN335-C

Devido ao processo de retificação otimizado, a nova geração de escareadores da **MASTER-PROF**, garante um processo de corte até 25% mais rápido com uma otimização de vida útil de aproximadamente 50%. O cabo **ROTASTOP**® (patenteado) foi totalmente desenhado para evitar a rotação na bucha e potencializar o trabalho. Com este escareador garante os melhores resultados, processos de corte mais rápidos e reduz os custos nas aplicações.



HSS-G para furos em chapa e tubo

Código	Medida Min. / Max.	Progres. Degraus	Nº Degraus	Comp. Total	ØCabo	PCS	€
MFE02	4 a 12	1	9	72	6	1	19,23
MFE04	4 a 20	2	9	85	10	1	25,89
MFE06	4 a 30	2	13	97	10	1	54,68
MFE10	5 a 38	1	14	95	12	1	67,05
MFE09	6 a 40	1	16	105	13	1	69,71
MFE08	40 a 50	1	11	100	13	1	166,15



Caixa plástica

Comp.: 3 unids
Cód.:MFBE10

Medida Min. / Max.	Unid.
4 a 12	1
4 a 20	1
4 a 30	1

99,78 €



HSS-G revestida a titânio para furar inox e aço tratado

Código	Medida Min. / Max.	Progres. Degraus	Nº Degraus	Comp. Total	ØCabo	PCS	€
MFET02	4 a 12	1	9	72	6	1	30,06
MFET04	4 a 20	2	9	85	10	1	49,18
MFET06	4 a 30	2	13	97	10	1	97,60
MFET09	6 a 40	1	16	105	13	1	123,08



Caixa plástica

Comp.: 3 unids
Cód.:MFBEET6

Medida Min. / Max.	Unid.
4 a 12	1
4 a 20	1
4 a 30	1

176,70 €



Helicoidais HSS-G

Código	Medida Min. / Max.	Progres. Degraus	Nº Degraus	Comp. Total	ØCabo	PCS	€
MFE40	4 a 12	1	5	80	6	1	28,65
MFE41	4 a 20	2	4	67	8	1	38,54
MFE42	6 a 30	2	4	98	10	1	61,82
MFE43	6 a 36	3	3	82	12	1	70,11



Caixa plástica

Comp.: 3 unids
Cód.:MFE49

Medida Min. / Max.	Unid.
4 a 12	1
4 a 20	1
6 a 30	1

129,01 €



Helicoidais HSS-G - cabo sextavado

Código	Medida Min. / Max.	Progres. Degraus	Nº Degraus	Comp. Total	ØCabo	PCS	€
MFE80	4 a 12	1	5	80	6	1	26,40
MFE81	4 a 20	2	4	67	8	1	30,20
MFE82	6 a 30	2	4	98	10	1	58,10



Caixa plástica

Comp.: 3 unids
Cód.:MFE89

Medida Min. / Max.	Unid.
4 a 12	1
4 a 20	1
6 a 30	1

114,70 €



Helicoidais HSS-G + TIALN para inox

Código	Medida Min. / Max.	Progres. Degraus	Nº Degraus	Comp. Total	ØCabo	PCS	€
MFE60	4 a 12	1	5	80	6	1	35,59
MFE61	4 a 20	2	4	67	8	1	41,63
MFE62	6 a 30	2	4	98	10	1	76,77
MFE63	6 a 36	3	3	82	12	1	87,07



Caixa plástica

Comp.: 3 unids
Cód.:MFE69

Medida Min. / Max.	Unid.
4 a 12	1
4 a 20	1
6 a 30	1

153,99 €



Série curta - encabadouro \varnothing 8mm

Código	\varnothing	\varnothing d mm	L mm	l mm	PCS	€
PROF1000	3	8	60	12	1	9,33
PROF1001	4	8	60	12	1	9,33
PROF1002	5	8	60	12	1	9,33
PROF1003	6	8	60	14	1	9,33
PROF1004	7	8	60	14	1	11,42
PROF1005	8	8	80	15	1	11,42
PROF1006	10	10	80	15	1	11,74

Série curta - encabadouro \varnothing 6mm

Código	\varnothing	\varnothing d mm	L mm	l mm	PCS	€
PROF1007	3	6	60	12	1	9,33
PROF1008	4	6	60	12	1	9,33
PROF1009	5	6	60	12	1	9,33
PROF1010	6	6	60	14	1	9,33

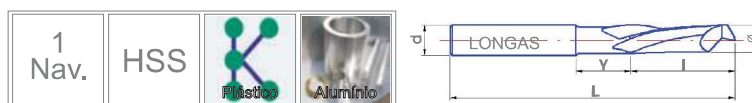

Série longa - encabadouro \varnothing 8mm

Código	\varnothing	\varnothing d mm	L mm	l mm	Y mm	PCS	€
PROF1011	4	8	80	16	29	1	13,20
PROF1012	5	8	80	16	29	1	13,20
PROF1013	6	8	90	16	29	1	13,20
PROF1014	8	8	100	28	40	1	14,65

Série longa - encabadouro \varnothing 6mm

Código	\varnothing	\varnothing d mm	L mm	l mm	Y mm	PCS	€
PROF1015	5	6	80	14	31	1	13,20
PROF1016	6	6	80	14	31	1	13,20

HSSE 8% Co



TIALSIN

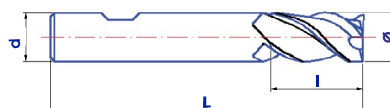

HSSE 8% Co

Código	Ø	d mm	L mm	l mm	PCS	€
PROF2100	2,00	6	48	4	1	8,62
PROF2101	2,50	6	49	5	1	8,62
PROF2102	3,00	6	49	5	1	8,62
PROF2103	3,50	6	50	6	1	9,35
PROF2104	4,00	6	51	7	1	8,62
PROF2105	4,50	6	52	8	1	10,30
PROF2106	5,00	6	52	8	1	8,62
PROF2107	5,50	6	52	8	1	10,59
PROF2108	6,00	6	52	8	1	8,62
PROF2109	6,50	10	60	10	1	13,86
PROF2110	7,00	10	60	10	1	13,44
PROF2111	7,50	10	61	11	1	13,34
PROF2112	8,00	10	61	11	1	11,09
PROF2113	8,50	10	61	11	1	14,97
PROF2114	9,00	10	61	11	1	13,76
PROF2115	9,50	10	61	11	1	14,65
PROF2116	10,00	10	63	13	1	10,99
PROF2117	11,00	12	70	13	1	16,82
PROF2118	12,00	12	73	16	1	14,75
PROF2119	13,00	12	73	16	1	21,67
PROF2120	14,00	12	73	16	1	21,67
PROF2121	15,00	12	73	16	1	24,24
PROF2122	16,00	16	79	19	1	21,32
PROF2123	17,00	16	79	19	1	28,85
PROF2124	18,00	16	79	19	1	28,85
PROF2125	19,00	16	79	19	1	36,39
PROF2126	20,00	20	88	22	1	34,43
PROF2127	22,00	20	88	22	1	42,88
PROF2128	24,00	25	102	26	1	60,33
PROF2129	25,00	25	102	26	1	57,10
PROF2130	28,00	25	102	26	1	72,24
PROF2131	30,00	25	102	26	1	82,30
PROF2132	32,00	32	112	32	1	84,55
PROF2133	36,00	32	112	32	1	113,09
PROF2134	40,00	40	130	48	1	138,86

TIALSIN

Código	Ø	d mm	L mm	l mm	PCS	€
PROF2200	2,00	6	48	4	1	15,72
PROF2201	2,50	6	49	5	1	15,72
PROF2202	3,00	6	49	5	1	15,72
PROF2203	3,50	6	50	6	1	16,30
PROF2204	4,00	6	51	7	1	15,72
PROF2205	4,50	6	52	8	1	17,04
PROF2206	5,00	6	52	8	1	15,72
PROF2207	5,50	6	52	8	1	17,27
PROF2208	6,00	6	52	8	1	15,72
PROF2209	6,50	10	60	10	1	23,93
PROF2210	7,00	10	60	10	1	23,63
PROF2211	7,50	10	61	11	1	23,54
PROF2212	8,00	10	61	11	1	21,92
PROF2213	8,50	10	61	11	1	24,74
PROF2214	9,00	10	61	11	1	23,85
PROF2215	9,50	10	61	11	1	24,50
PROF2216	10,00	10	63	13	1	21,85
PROF2217	11,00	12	70	13	1	26,90
PROF2218	12,00	12	73	16	1	25,41
PROF2219	13,00	12	73	16	1	33,18
PROF2220	14,00	12	73	16	1	33,18
PROF2221	15,00	12	73	16	1	35,21
PROF2222	16,00	16	79	19	1	32,88
PROF2223	17,00	16	79	19	1	49,56
PROF2224	18,00	16	79	19	1	47,41
PROF2225	19,00	16	79	19	1	52,87
PROF2226	20,00	20	88	22	1	54,35
PROF2227	22,00	20	88	22	1	67,67
PROF2228	24,00	25	102	26	1	87,73
PROF2229	25,00	25	102	26	1	85,18
PROF2230	28,00	25	102	26	1	97,13
PROF2231	30,00	25	102	26	1	105,07
PROF2232	32,00	32	112	32	1	129,16
PROF2233	36,00	32	112	32	1	196,58
PROF2234	40,00	40	130	48	1	215,22

HSSE 8% Co



TIALSIN

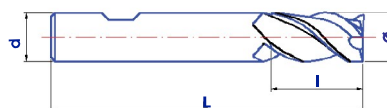

HSSE 8% Co

Código	Ø	d mm	L mm	l mm	PCS	€
PROF3100	2,00	6	51	7	1	10,33
PROF3101	2,50	6	51	8	1	10,33
PROF3102	3,00	6	52	8	1	10,08
PROF3103	3,50	6	55	11	1	10,65
PROF3104	4,00	6	55	11	1	10,33
PROF3105	4,50	6	57	11	1	11,39
PROF3106	5,00	6	57	13	1	10,33
PROF3107	5,50	6	57	13	1	13,59
PROF3108	6,00	6	57	13	1	11,19
PROF3109	6,50	10	66	16	1	16,57
PROF3110	7,00	10	66	16	1	15,17
PROF3111	7,50	10	66	16	1	17,69
PROF3112	8,00	10	69	19	1	13,65
PROF3113	8,50	10	69	19	1	18,64
PROF3114	9,00	10	69	19	1	16,89
PROF3115	9,50	10	72	19	1	20,18
PROF3116	10,00	10	72	22	1	14,69
PROF3117	11,00	12	79	22	1	20,46
PROF3118	12,00	12	83	26	1	18,44
PROF3119	13,00	12	83	26	1	26,31
PROF3120	14,00	12	83	26	1	25,92
PROF3121	15,00	12	83	26	1	28,36
PROF3122	16,00	16	92	32	1	27,68
PROF3123	17,00	16	92	32	1	38,59
PROF3124	18,00	16	92	32	1	34,71
PROF3125	19,00	16	92	32	1	46,58
PROF3126	20,00	20	104	38	1	39,89
PROF3127	22,00	20	104	38	1	55,41
PROF3128	25,00	25	121	45	1	72,03
PROF3129	28,00	25	121	45	1	86,01
PROF3130	30,00	25	121	45	1	99,55
PROF3131	32,00	32	133	53	1	104,81

TIALSIN

Código	Ø	d mm	L mm	l mm	PCS	€
PROF3200	2,00	6	51	7	1	16,05
PROF3201	2,50	6	51	8	1	16,05
PROF3202	3,00	6	52	8	1	15,78
PROF3203	3,50	6	55	11	1	16,54
PROF3204	4,00	6	55	11	1	16,19
PROF3205	4,50	6	57	11	1	17,73
PROF3206	5,00	6	57	13	1	16,75
PROF3207	5,50	6	57	13	1	17,73
PROF3208	6,00	6	57	13	1	17,96
PROF3209	6,50	10	66	16	1	27,58
PROF3210	7,00	10	66	16	1	25,95
PROF3211	7,50	10	66	16	1	27,79
PROF3212	8,00	10	69	19	1	26,19
PROF3213	8,50	10	69	19	1	28,47
PROF3214	9,00	10	69	19	1	28,28
PROF3215	9,50	10	72	19	1	29,56
PROF3216	10,00	10	72	22	1	26,52
PROF3217	11,00	12	79	22	1	31,68
PROF3218	12,00	12	83	26	1	30,42
PROF3219	13,00	12	83	26	1	36,30
PROF3220	14,00	12	83	26	1	37,01
PROF3221	15,00	12	83	26	1	36,84
PROF3222	16,00	16	92	32	1	50,43
PROF3223	17,00	16	92	32	1	59,16
PROF3224	18,00	16	92	32	1	56,41
PROF3225	19,00	16	92	32	1	65,53
PROF3226	20,00	20	104	38	1	62,94
PROF3227	22,00	20	104	38	1	75,41
PROF3228	25,00	25	121	45	1	96,68
PROF3229	28,00	25	121	45	1	105,85
PROF3230	30,00	25	121	45	1	120,97
PROF3231	32,00	32	133	53	1	156,47

HSSE 8% Co



TIALSIN

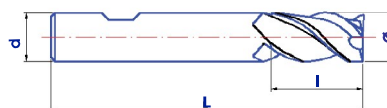

HSSE 8% Co

Código	Ø	d mm	L mm	l mm	PCS	€
PROF4100	2,00	6	51	7	1	10,29
PROF4101	2,50	6	51	8	1	10,29
PROF4102	3,00	6	52	8	1	10,29
PROF4103	3,50	6	54	10	1	10,59
PROF4104	4,00	6	55	11	1	10,29
PROF4105	4,50	6	55	11	1	10,59
PROF4106	5,00	6	57	13	1	10,29
PROF4107	5,50	6	57	13	1	16,47
PROF4108	6,00	6	57	13	1	10,29
PROF4109	6,50	10	66	16	1	16,00
PROF4110	7,00	10	66	16	1	15,09
PROF4111	7,50	10	66	16	1	18,89
PROF4112	8,00	10	69	19	1	12,47
PROF4113	8,50	10	69	19	1	19,72
PROF4114	9,00	10	69	19	1	15,77
PROF4115	9,50	10	69	19	1	20,85
PROF4116	10,00	10	63	22	1	14,34
PROF4117	11,00	12	72	22	1	19,76
PROF4118	12,00	12	79	26	1	16,98
PROF4119	13,00	12	83	26	1	25,41
PROF4120	14,00	12	83	26	1	24,00
PROF4121	15,00	12	83	26	1	27,38
PROF4122	16,00	16	92	32	1	26,73
PROF4123	17,00	16	92	32	1	32,93
PROF4124	18,00	16	92	32	1	32,93
PROF4125	19,00	16	92	32	1	38,54
PROF4126	20,00	20	104	38	1	38,54
PROF4127	22,00	20	104	38	1	53,51
PROF4128	24,00	25	121	45	1	66,49
PROF4129	25,00	25	121	45	1	66,49
PROF4130	26,00	25	121	45	1	69,76
PROF4131	28,00	25	121	45	1	83,08
PROF4132	30,00	25	121	45	1	96,16
PROF4133	32,00	32	133	53	1	99,05
PROF4134	36,00	32	133	53	1	129,62
PROF4135	40,00	40	155	63	1	155,83

A partir da medida 25mm sem corte ao centro

TIALSIN

Código	Ø	d mm	L mm	l mm	PCS	€
PROF4400	2,00	6	51	7	1	17,73
PROF4401	2,50	6	51	8	1	17,73
PROF4402	3,00	6	52	8	1	17,73
PROF4403	3,50	6	54	10	1	18,01
PROF4404	4,00	6	55	11	1	17,73
PROF4405	4,50	6	55	11	1	18,01
PROF4406	5,00	6	57	13	1	17,73
PROF4407	5,50	6	57	13	1	23,03
PROF4408	6,00	6	57	13	1	17,73
PROF4409	6,50	10	66	16	1	26,46
PROF4410	7,00	10	66	16	1	25,75
PROF4411	7,50	10	66	16	1	28,74
PROF4412	8,00	10	69	19	1	23,70
PROF4413	8,50	10	69	19	1	29,40
PROF4414	9,00	10	69	19	1	26,29
PROF4415	9,50	10	69	19	1	30,28
PROF4416	10,00	10	63	22	1	25,17
PROF4417	11,00	12	72	22	1	30,26
PROF4418	12,00	12	79	26	1	28,08
PROF4419	13,00	12	83	26	1	37,85
PROF4420	14,00	12	83	26	1	36,63
PROF4421	15,00	12	83	26	1	39,54
PROF4422	16,00	16	92	32	1	38,99
PROF4423	17,00	16	92	32	1	54,79
PROF4424	18,00	16	92	32	1	52,41
PROF4425	19,00	16	92	32	1	56,82
PROF4426	20,00	20	104	38	1	59,60
PROF4427	22,00	20	104	38	1	77,98
PROF4428	24,00	25	121	45	1	97,10
PROF4429	25,00	25	121	45	1	97,10
PROF4430	26,00	25	121	45	1	109,27
PROF4431	28,00	25	121	45	1	111,34
PROF4432	30,00	25	121	45	1	122,55
PROF4433	32,00	32	133	53	1	145,82
PROF4434	36,00	32	133	53	1	216,64
PROF4435	40,00	40	155	63	1	237,21

A partir da medida 25mm sem corte ao centro

HSSE 8% Co



TIALSIN



HSSE 8% Co

Código	Ø	d mm	L mm	l mm	PCS	€
PROF4300	6,00	6	57	13	1	24,08
PROF4301	7,00	10	66	16	1	28,99
PROF4302	8,00	10	69	19	1	25,14
PROF4303	9,00	10	69	19	1	30,09
PROF4304	10,00	10	69	22	1	25,17
PROF4305	11,00	12	72	22	1	36,81
PROF4306	12,00	12	79	26	1	30,10
PROF4307	13,00	12	83	26	1	42,79
PROF4308	14,00	12	83	26	1	35,23
PROF4309	15,00	12	83	26	1	46,32
PROF4310	16,00	16	83	32	1	41,51
PROF4311	17,00	16	92	32	1	57,02
PROF4312	18,00	16	92	32	1	45,56
PROF4313	19,00	16	92	32	1	66,96
PROF4314	20,00	20	92	38	1	57,09
PROF4315	22,00	20	104	38	1	67,58
PROF4316	24,00	25	104	45	1	85,01
PROF4317	25,00	25	121	45	1	84,39
PROF4318	26,00	25	121	45	1	97,95
PROF4319	28,00	25	121	45	1	97,61
PROF4320	30,00	25	121	45	1	108,40
PROF4321	32,00	32	133	53	1	118,86
PROF4322	36,00	32	133	53	1	140,76
PROF4323	40,00	40	155	63	1	158,27

TIALSIN

Código	Ø	d mm	L mm	l mm	PCS	€
PROF4500	6,00	6	57	13	1	27,62
PROF4501	7,00	10	66	16	1	37,68
PROF4502	8,00	10	69	19	1	34,68
PROF4503	9,00	10	69	19	1	38,55
PROF4504	10,00	10	69	22	1	33,63
PROF4505	11,00	12	72	22	1	50,73
PROF4506	12,00	12	79	26	1	45,51
PROF4507	13,00	12	83	26	1	56,33
PROF4508	14,00	12	83	26	1	49,49
PROF4509	15,00	12	83	26	1	59,72
PROF4510	16,00	16	83	32	1	55,00
PROF4511	17,00	16	92	32	1	76,34
PROF4512	18,00	16	92	32	1	64,34
PROF4513	19,00	16	92	32	1	84,35
PROF4514	20,00	20	92	38	1	79,65
PROF4515	22,00	20	104	38	1	88,13
PROF4516	24,00	25	104	45	1	100,29
PROF4517	25,00	25	121	45	1	108,15
PROF4518	26,00	25	121	45	1	121,05
PROF4519	28,00	25	121	45	1	120,77
PROF4520	30,00	25	121	45	1	129,51
PROF4521	32,00	32	133	53	1	166,53
PROF4522	36,00	32	133	53	1	213,75
PROF4523	40,00	40	155	63	1	226,23



Metal-Duro (K30)

Código	\varnothing	d mm	L mm	l mm	PCS	€
PROF6000	1,00	1,00	40	3,00	1	21,14
PROF6001	1,50	1,50	40	3,00	1	21,14
PROF6002	2,00	2,00	40	8,00	1	12,69
PROF6003	2,50	2,50	40	8,00	1	12,69
PROF6004	3,00	3,00	38	8,00	1	10,05
PROF6005	3,50	3,50	50	8,00	1	10,98
PROF6006	4,00	4,00	50	8,00	1	11,14
PROF6007	4,50	4,50	50	8,00	1	14,68
PROF6008	5,00	5,00	50	10,00	1	14,14
PROF6009	5,50	5,50	57	10,00	1	18,38
PROF6010	6,00	6,00	57	10,00	1	15,63
PROF6011	6,50	6,50	60	13,00	1	24,37
PROF6012	8,00	8,00	63	16,00	1	22,79
PROF6013	8,50	8,50	67	16,00	1	38,25
PROF6014	10,00	10,00	72	19,00	1	32,95
PROF6015	12,00	12,00	83	22,00	1	46,07
PROF6016	14,00	14,00	83	22,00	1	65,89
PROF6017	16,00	16,00	92	26,00	1	85,11
PROF6018	18,00	18,00	92	26,00	1	112,57
PROF6019	20,00	20,00	104	32,00	1	142,77

Metal Duro (K30) X-TIALN

Código	\varnothing	d mm	L mm	l mm	PCS	€
PROF7000	1,00	1,00	40	3,00	1	23,94
PROF7001	1,50	1,50	40	3,00	1	23,94
PROF7002	2,00	2,00	40	8,00	1	16,53
PROF7003	2,50	2,50	40	8,00	1	16,53
PROF7004	3,00	3,00	38	8,00	1	13,45
PROF7005	3,50	3,50	50	8,00	1	14,63
PROF7006	4,00	4,00	50	8,00	1	14,63
PROF7007	4,50	4,50	50	8,00	1	17,76
PROF7008	5,00	5,00	50	10,00	1	17,49
PROF7009	5,50	5,50	57	10,00	1	21,34
PROF7010	6,00	6,00	57	10,00	1	20,20
PROF7011	6,50	6,50	60	13,00	1	32,74
PROF7012	8,00	8,00	63	16,00	1	28,17
PROF7013	8,50	8,50	67	16,00	1	43,64
PROF7014	10,00	10,00	72	19,00	1	37,07
PROF7015	12,00	12,00	83	22,00	1	49,75
PROF7016	14,00	14,00	83	22,00	1	71,39
PROF7017	16,00	16,00	92	26,00	1	90,60
PROF7018	18,00	18,00	92	26,00	1	115,32
PROF7019	20,00	20,00	104	32,00	1	151,01

Fresas frontais de 3 navalhas cabo cilíndrico c/centro Metal Duro e X-TIALN

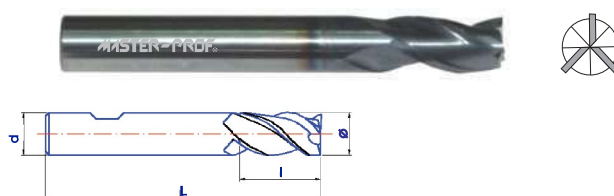

Metal Duro (K30)

Código	\varnothing	d mm	L mm	l mm	PCS	€
PROF6100	1,00	1,00	40	3,00	1	21,14
PROF6101	1,50	1,50	40	3,00	1	21,14
PROF6102	2,00	2,00	40	8,00	1	12,69
PROF6103	2,50	2,50	40	8,00	1	12,69
PROF6104	3,00	3,00	38	8,00	1	10,05
PROF6105	3,50	3,50	50	8,00	1	10,98
PROF6106	4,00	4,00	50	8,00	1	11,14
PROF6107	4,50	4,50	50	8,00	1	14,68
PROF6108	5,00	5,00	50	10,00	1	14,14
PROF6109	5,50	5,50	57	10,00	1	18,38
PROF6110	6,00	6,00	57	10,00	1	15,63
PROF6111	6,50	6,50	60	13,00	1	24,37
PROF6112	8,00	8,00	63	16,00	1	22,79
PROF6113	8,50	8,50	67	16,00	1	38,25
PROF6114	10,00	10,00	72	19,00	1	32,95
PROF6115	12,00	12,00	83	22,00	1	46,07
PROF6116	14,00	14,00	83	22,00	1	65,89
PROF6117	16,00	16,00	92	26,00	1	85,11
PROF6118	18,00	18,00	92	26,00	1	112,57
PROF6119	20,00	20,00	104	32,00	1	142,77

Metal Duro (K30) X-TIALN

Código	\varnothing	d mm	L mm	l mm	PCS	€
PROF7200	1,00	1,00	40	3,00	1	23,94
PROF7201	1,50	1,50	40	3,00	1	23,94
PROF7202	2,00	2,00	40	8,00	1	16,53
PROF7203	2,50	2,50	40	8,00	1	16,53
PROF7204	3,00	3,00	38	8,00	1	13,45
PROF7205	3,50	3,50	50	8,00	1	14,62
PROF7206	4,00	4,00	50	8,00	1	14,62
PROF7207	4,50	4,50	50	8,00	1	17,76
PROF7208	5,00	5,00	50	10,00	1	17,48
PROF7209	5,50	5,50	57	10,00	1	21,33
PROF7210	6,00	6,00	57	10,00	1	20,20
PROF7211	6,50	6,50	60	13,00	1	32,74
PROF7212	8,00	8,00	63	16,00	1	28,17
PROF7213	8,50	8,50	67	16,00	1	43,64
PROF7214	10,00	10,00	72	19,00	1	37,07
PROF7215	12,00	12,00	83	22,00	1	49,74
PROF7216	14,00	14,00	83	22,00	1	71,39
PROF7217	16,00	16,00	92	26,00	1	90,60
PROF7218	18,00	18,00	92	26,00	1	115,32
PROF7219	20,00	20,00	104	32,00	1	151,01

Metal Duro (K30)



Metal Duro (K30) X-TIALN



Metal Duro (K30)

Código	Ø	d mm	L mm	l mm	PCS	€
PROF6200	1,00	1,00	40	3,00	1	21,14
PROF6201	1,50	1,50	40	3,00	1	21,14
PROF6202	2,00	2,00	40	8,00	1	12,69
PROF6203	2,50	2,50	40	8,00	1	12,69
PROF6204	3,00	3,00	38	8,00	1	10,05
PROF6205	3,50	3,50	50	8,00	1	10,98
PROF6206	4,00	4,00	50	8,00	1	11,14
PROF6207	4,50	4,50	50	8,00	1	14,68
PROF6208	5,00	5,00	50	10,00	1	14,14
PROF6209	5,50	5,50	57	10,00	1	18,38
PROF6210	6,00	6,00	57	10,00	1	15,63
PROF6211	6,50	6,50	60	13,00	1	24,37
PROF6212	8,00	8,00	63	16,00	1	22,58
PROF6213	8,50	8,50	67	16,00	1	38,25
PROF6214	10,00	10,00	72	19,00	1	32,95
PROF6215	12,00	12,00	83	22,00	1	46,07
PROF6216	14,00	14,00	83	22,00	1	65,89
PROF6217	16,00	16,00	92	26,00	1	90,60
PROF6218	18,00	18,00	92	26,00	1	112,57
PROF6219	20,00	20,00	104	32,00	1	142,77

Metal Duro (K30) X-TIALN

Código	Ø	d mm	L mm	l mm	PCS	€
PROF7300	1,00	1,00	40	3,00	1	23,94
PROF7301	1,50	1,50	40	3,00	1	23,94
PROF7302	2,00	2,00	40	8,00	1	16,53
PROF7303	2,50	2,50	40	8,00	1	16,53
PROF7304	3,00	3,00	38	8,00	1	13,45
PROF7305	3,50	3,50	50	8,00	1	14,63
PROF7306	4,00	4,00	50	8,00	1	14,63
PROF7307	4,50	4,50	50	8,00	1	17,76
PROF7308	5,00	5,00	50	10,00	1	17,49
PROF7309	5,50	5,50	57	10,00	1	21,33
PROF7310	6,00	6,00	57	10,00	1	20,20
PROF7311	6,50	6,50	60	13,00	1	32,74
PROF7312	8,00	8,00	63	16,00	1	28,17
PROF7313	8,50	8,50	67	16,00	1	43,64
PROF7314	10,00	10,00	72	19,00	1	37,17
PROF7315	12,00	12,00	83	22,00	1	49,75
PROF7316	14,00	14,00	83	22,00	1	71,39
PROF7317	16,00	16,00	92	26,00	1	92,30
PROF7318	18,00	18,00	92	26,00	1	115,32
PROF7319	20,00	20,00	104	32,00	1	151,01

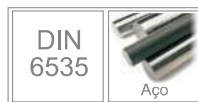
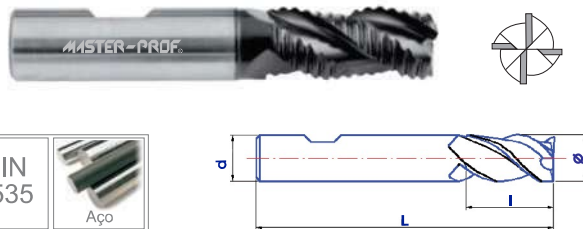
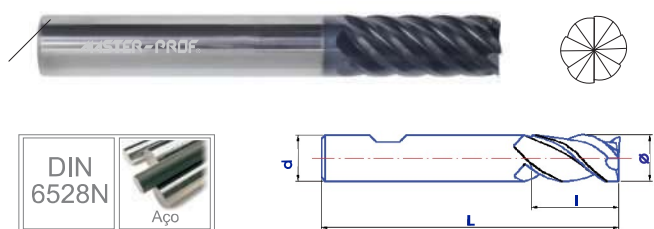

Fresas frontais de cabo cilíndrico c/centro super acabamento Metal Duro X-TIALN (K30)

Código	Ø	d mm	L mm	l mm	PCS	€
PROF7400	6,00	6	57	13	1	36,69
PROF7401	8,00	8	63	19	1	46,78
PROF7402	10,00	10	72	22	1	64,20
PROF7403	12,00	12	83	26	1	87,66
PROF7404	16,00	16	93	32	1	165,29
PROF7405	20,00	20	104	38	1	258,76

Fresas frontais de cabo cilíndrico desbaste c/centro Metal Duro X-TIALN (K30)

Código	Ø	d mm	L mm	l mm	PCS	€
PROF7409	6,00	6	60	16	1	36,69
PROF7410	8,00	8	70	18	1	46,78
PROF7411	10,00	10	70	22	1	64,20
PROF7412	12,00	12	80	26	1	87,66
PROF7413	16,00	16	100	32	1	165,29
PROF7414	20,00	20	104	38	1	258,76

Metal Duro (K30)



Metal Duro (K30) X-TIALN

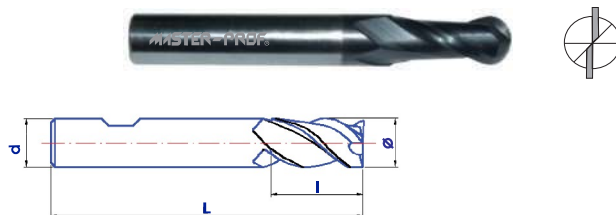

Metal Duro (K30)

Código	∅	d mm	L mm	l mm	PCS	€
PROF5000	1,00	1,00	40	3	1	32,72
PROF5001	1,50	1,50	40	3	1	32,72
PROF5002	2,00	2,00	40	8	1	13,93
PROF5003	2,50	2,50	40	8	1	14,28
PROF5004	3,00	3,00	40	10	1	17,01
PROF5005	3,50	3,50	40	10	1	17,37
PROF5006	4,00	4,00	40	12	1	17,73
PROF5007	4,50	4,50	50	12	1	19,40
PROF5008	5,00	5,00	50	14	1	22,26
PROF5009	5,50	5,50	50	14	1	23,32
PROF5010	6,00	6,00	50	16	1	24,15
PROF5011	6,50	6,50	50	16	1	26,18
PROF5012	8,00	8,00	60	18	1	32,96
PROF5013	8,50	8,50	60	18	1	36,76
PROF5014	10,00	10,00	70	22	1	45,80
PROF5015	12,00	12,00	70	25	1	59,37
PROF5016	14,00	14,00	75	28	1	77,25
PROF5017	16,00	16,00	80	32	1	101,89
PROF5018	18,00	18,00	80	32	1	134,09
PROF5019	20,00	20,00	104	38	1	178,22

Metal Duro (K30) X-TIALN

Código	∅	d mm	L mm	l mm	PCS	€
PROF5020	1,00	1,00	40	3	1	36,05
PROF5021	1,50	1,50	40	3	1	36,05
PROF5022	2,00	2,00	40	8	1	17,37
PROF5023	2,50	2,50	40	8	1	18,43
PROF5024	3,00	3,00	40	10	1	21,06
PROF5025	3,50	3,50	40	10	1	21,41
PROF5026	4,00	4,00	40	12	1	21,77
PROF5027	4,50	4,50	50	12	1	24,87
PROF5028	5,00	5,00	50	14	1	27,72
PROF5029	5,50	5,50	50	14	1	28,80
PROF5030	6,00	6,00	50	16	1	29,63
PROF5031	6,50	6,50	50	16	1	32,72
PROF5032	8,00	8,00	60	18	1	39,61
PROF5033	8,50	8,50	60	18	1	44,73
PROF5034	10,00	10,00	70	22	1	53,78
PROF5035	12,00	12,00	70	25	1	67,24
PROF5036	14,00	14,00	75	28	1	86,02
PROF5037	16,00	16,00	80	32	1	111,98
PROF5038	18,00	18,00	80	32	1	148,72
PROF5039	20,00	20,00	104	38	1	187,81

Fresas frontais de 2 navalhas boleadas longas em Metal Duro e X-TIALN

Metal Duro (K30)



Metal Duro (K30) X-TIALN

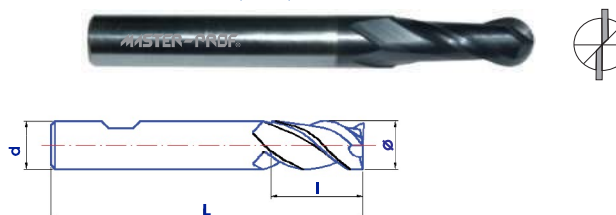

Metal Duro (K30)

Código	∅	d mm	L mm	l mm	PCS	€
PROF5100	2,00	2,00	50	20	1	17,85
PROF5101	3,00	3,00	55	20	1	19,15
PROF5102	4,00	4,00	60	20	1	24,15
PROF5103	5,00	5,00	60	20	1	25,82
PROF5104	6,00	6,00	65	24	1	31,18
PROF5105	8,00	8,00	80	32	1	43,54
PROF5106	10,00	10,00	80	32	1	55,21
PROF5107	12,00	12,00	100	50	1	86,61
PROF5108	14,00	14,00	100	55	1	106,13
PROF5109	16,00	16,00	120	60	1	147,13
PROF5110	18,00	18,00	120	60	1	179,76
PROF5111	20,00	20,00	130	60	1	235,92

Metal Duro (K30) X-TIALN

Código	∅	d mm	L mm	l mm	PCS	€
PROF5200	2,00	2,00	50	20	1	21,30
PROF5201	3,00	3,00	55	20	1	23,20
PROF5202	4,00	4,00	60	20	1	28,20
PROF5203	5,00	5,00	60	20	1	31,29
PROF5204	6,00	6,00	65	24	1	36,64
PROF5205	8,00	8,00	80	32	1	51,86
PROF5206	10,00	10,00	80	32	1	65,50
PROF5207	12,00	12,00	100	50	1	96,62
PROF5208	14,00	14,00	100	55	1	116,83
PROF5209	16,00	16,00	120	60	1	161,32
PROF5210	18,00	18,00	120	60	1	195,83
PROF5211	20,00	20,00	130	60	1	256,57



HSS-CO 8%

Jogo de fresas frontais

COMPOSIÇÃO		∅ 3, 4, 5, 6, 8, 10, 12	7 peças
2 Navalhas	3 Navalhas	4 Navalhas	
CÓDIGO: PROF7910	CÓDIGO: PROF7912	CÓDIGO: PROF7914	
jogo em acrílico	jogo em acrílico	jogo em acrílico	
71,30 €	88,70 €	84,93 €	



HSS-CO - X-TIALN

Jogo de fresas frontais

COMPOSIÇÃO		∅ 3, 4, 5, 6, 8, 10, 12	7 peças
2 Navalhas	3 Navalhas	4 Navalhas	
CÓDIGO: PROF7911	CÓDIGO: PROF7913	CÓDIGO: PROF7958	
jogo em acrílico	jogo em acrílico	jogo em acrílico	
116,93 €	149,81 €	147,88 €	



HSS-CO 8%

Jogo de fresas frontais 4 navalhas para desbaste

COMPOSIÇÃO		∅ 6, 8, 10, 12, 14	5 peças
CÓDIGO: PROF7916	Jogo em acrílico		139,72 €



HSS-CO - X-TIALN

Jogo de fresas frontais 4 navalhas para desbaste

COMPOSIÇÃO		∅ 6, 8, 10, 12, 14	5 peças
CÓDIGO: PROF7957	Jogo em acrílico		190,92 €



Metal Duro (K30)

Jogo de fresas frontais

COMPOSIÇÃO Ø 3, 4, 5, 6, 8, 10, 12		7 peças
2 Navalhas CÓDIGO: PROF7918 jogo em acrílico	3 Navalhas CÓDIGO: PROF7920 jogo em acrílico	4 Navalhas CÓDIGO: PROF7922 jogo em acrílico
152,77 €	152,77 €	152,77 €



Metal Duro X-TIALN (K30)

Jogo de fresas frontais

COMPOSIÇÃO Ø 3, 4, 5, 6, 8, 10, 12		7 peças
2 Navalhas CÓDIGO: PROF7950 jogo em acrílico	3 Navalhas CÓDIGO: PROF7951 jogo em acrílico	4 Navalhas CÓDIGO: PROF7952 jogo em acrílico
180,73 €	180,73 €	180,73 €



Metal Duro X-TIALN (K30)

Jogo de fresas frontais 4 navalhas para desbaste

COMPOSIÇÃO Ø 6, 8, 10, 12, 16		5 peças
CÓDIGO: PROF7924 Jogo em acrílico		400,62 €



Metal Duro X-TIALN (K30)

Jogo de fresas frontais 4 navalhas para acabamento

COMPOSIÇÃO Ø 6, 8, 10, 12, 16		5 peças
CÓDIGO: PROF7953 Jogo em acrílico		400,62 €



Metal Duro (K30)

Jogo de fresas frontais boleadas

COMPOSIÇÃO Ø 3, 4, 5, 6, 8, 10, 12 7 peças

CÓDIGO: PROF7926 Jogo em acrílico 219,28 €



Metal Duro X-TIALN (K30)

Jogo de fresas frontais boleadas

COMPOSIÇÃO Ø 3, 4, 5, 6, 8, 10, 12 7 peças

CÓDIGO: PROF7954 Jogo em acrílico 260,80 €



Metal Duro X-TIALN (K30)

Jogo de fresas frontais

COMPOSIÇÃO Ø 3, 4, 5, 6, 8, 10 6 peças

2 Navalhas
CÓDIGO: PROF7900
caixa plástica

131,11 €

3 Navalhas
CÓDIGO: PROF7901
caixa plástica

131,11 €

4 Navalhas
CÓDIGO: PROF7902
caixa plástica

131,11 €



Jogo de fresas frontais **HSS-CO**

COMPOSIÇÃO Ø 4, 5, 6, 8, 10, 12

2 Navalhas
CÓDIGO: PROF7930
caixa plástica
6 peças

84,12 €

4 Navalhas
CÓDIGO: PROF7931
caixa plástica
6 peças

95,77 €

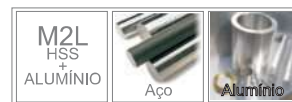
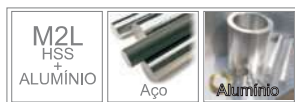

Série curta

Código	Ø	PCS	€
MFME01	12	1	20,05
MFME02	13	1	20,05
MFME03	14	1	20,78
MFME04	15	1	21,65
MFME05	16	1	22,52
MFME06	17	1	23,24
MFME07	18	1	24,11
MFME08	19	1	24,69
MFME09	20	1	25,86
MFME10	21	1	27,60
MFME11	22	1	28,61
MFME12	23	1	29,79
MFME13	24	1	30,94
MFME14	25	1	31,96
MFME15	26	1	33,11
MFME16	27	1	33,42
MFME17	28	1	35,44
MFME18	29	1	36,62
MFME19	30	1	38,28
MFME20	31	1	40,97
MFME21	32	1	43,87
MFME22	33	1	46,20
MFME23	34	1	54,34
MFME24	35	1	60,14
MFME25	36	1	61,61
MFME26	37	1	62,70
MFME27	38	1	63,34
MFME28	39	1	63,92
MFME29	40	1	64,50
MFME30	41	1	65,67

Série curta

Código	Ø	PCS	€
MFME31	42	1	70,03
MFME32	43	1	73,23
MFME39	44	1	74,98
MFME33	45	1	76,42
MFME34	46	1	78,16
MFME35	47	1	79,61
MFME36	48	1	82,80
MFME37	49	1	83,40
MFME38	50	1	88,33
MFME40	51	1	90,17
MFME41	52	1	92,22
MFME42	53	1	94,23
MFME43	54	1	96,29
MFME44	55	1	98,89
MFME45	56	1	99,91
MFME46	57	1	101,86
MFME47	58	1	103,79
MFME48	59	1	105,75
MFME49	60	1	107,74
MFME51	61	1	123,77
MFME52	62	1	121,39
MFME53	63	1	123,50
MFME54	64	1	126,25
MFME55	65	1	128,99
MFME56	66	1	131,79
MFME57	67	1	134,59
MFME58	68	1	137,49
MFME59	69	1	140,39
MFME60	70	1	143,34

Série longa

Código	Ø	PCS	€
MFMELO1	12	1	28,77
MFMELO2	13	1	28,77
MFMELO3	14	1	28,77
MFMELO4	15	1	31,96
MFMELO5	16	1	31,96
MFMELO6	17	1	33,11
MFMELO7	18	1	35,60
MFMELO8	19	1	36,32
MFMELO9	20	1	37,34
MFMELO10	21	1	41,55
MFMELO11	22	1	42,71
MFMELO12	23	1	44,17
MFMELO13	24	1	45,47
MFMELO14	25	1	46,78
MFMELO15	26	1	48,24
MFMELO16	27	1	50,54
MFMELO17	28	1	52,88
MFMELO18	29	1	54,91
MFMELO19	30	1	57,24
MFMELO20	31	1	60,14
MFMELO21	32	1	62,76
MFMELO22	33	1	65,67
MFMELO23	34	1	68,57
MFMELO24	35	1	71,48
MFMELO25	36	1	73,52
MFMELO26	37	1	78,46
MFMELO27	38	1	78,46
MFMELO28	39	1	84,27
MFMELO29	40	1	88,62
MFMELO30	41	1	90,08

Série longa

Código	Ø	PCS	€
MFMEL31	42	1	91,23
MFMEL32	43	1	93,56
MFMEL39	44	1	95,78
MFMEL33	45	1	97,64
MFMEL34	46	1	98,79
MFMEL35	47	1	104,32
MFMEL36	48	1	106,93
MFMEL37	49	1	107,50
MFMEL38	50	1	109,83
MFMEL40	51	1	111,05
MFMEL41	52	1	114,93
MFMEL42	53	1	118,32
MFMEL43	54	1	121,22
MFMEL44	55	1	124,57
MFMEL45	56	1	124,65
MFMEL46	57	1	127,34
MFMEL47	58	1	130,05
MFMEL48	59	1	132,82
MFMEL49	60	1	145,76
MFMEL51	61	1	150,53
MFMEL52	62	1	153,61
MFMEL53	63	1	156,74
MFMEL54	64	1	159,90
MFMEL55	65	1	163,11
MFMEL56	66	1	166,37
MFMEL57	67	1	169,72
MFMEL58	68	1	173,07
MFMEL59	69	1	176,50
MFMEL60	70	1	179,94



Série curta

Série curta

Série longa

Série longa

Código	Ø	PCS	€	Código	Ø	PCS	€
MFMECO01	12	1	23,22	MFMECO31	42	1	83,51
MFMECO02	13	1	24,70	MFMECO32	43	1	86,00
MFMECO03	14	1	27,65	MFMECO33	44	1	90,14
MFMECO04	15	1	29,64	MFMECO34	45	1	92,92
MFMECO05	16	1	31,12	MFMECO35	46	1	95,37
MFMECO06	17	1	31,12	MFMECO36	47	1	98,83
MFMECO07	18	1	31,12	MFMECO37	48	1	101,80
MFMECO08	19	1	31,12	MFMECO38	49	1	105,25
MFMECO09	20	1	31,12	MFMECO39	50	1	108,71
MFMECO10	21	1	32,13	MFMECO40	51	1	112,68
MFMECO11	22	1	33,10	MFMECO41	52	1	116,15
MFMECO12	23	1	35,08	MFMECO42	53	1	121,09
MFMECO13	24	1	37,07	MFMECO43	54	1	122,56
MFMECO14	25	1	39,52	MFMECO44	55	1	126,03
MFMECO15	26	1	42,01	MFMECO45	56	1	129,79
MFMECO16	27	1	43,48	MFMECO46	57	1	133,68
MFMECO17	28	1	45,98	MFMECO47	58	1	137,70
MFMECO18	29	1	48,42	MFMECO48	59	1	141,81
MFMECO19	30	1	50,92	MFMECO49	60	1	146,09
MFMECO20	31	1	53,36	MFMECO50	61	1	163,91
MFMECO21	32	1	55,86	MFMECO51	62	1	167,21
MFMECO22	33	1	58,30	MFMECO52	63	1	170,54
MFMECO23	34	1	61,27	MFMECO53	64	1	173,92
MFMECO24	35	1	63,75	MFMECO54	65	1	177,43
MFMECO25	36	1	66,20	MFMECO55	66	1	170,20
MFMECO26	37	1	69,19	MFMECO56	67	1	173,62
MFMECO27	38	1	71,65	MFMECO57	68	1	177,05
MFMECO28	39	1	74,60	MFMECO58	69	1	180,55
MFMECO29	40	1	77,10	MFMECO59	70	1	184,11
MFMECO30	41	1	80,05				

Código	Ø	PCS	€	Código	Ø	PCS	€
MFMELCO01	12	1	34,47	MFMELCO31	42	1	109,70
MFMELCO02	13	1	35,42	MFMELCO32	43	1	114,10
MFMELCO03	14	1	37,87	MFMELCO33	44	1	118,94
MFMELCO04	15	1	37,87	MFMELCO34	45	1	122,35
MFMELCO05	16	1	37,87	MFMELCO35	46	1	127,20
MFMELCO06	17	1	37,87	MFMELCO36	47	1	131,06
MFMELCO07	18	1	37,87	MFMELCO37	48	1	136,41
MFMELCO08	19	1	44,17	MFMELCO38	49	1	140,76
MFMELCO09	20	1	45,17	MFMELCO39	50	1	144,66
MFMELCO10	21	1	46,12	MFMELCO40	51	1	149,51
MFMELCO11	22	1	47,34	MFMELCO41	52	1	154,37
MFMELCO12	23	1	48,07	MFMELCO42	53	1	159,22
MFMELCO13	24	1	50,01	MFMELCO43	54	1	164,07
MFMELCO14	25	1	51,47	MFMELCO44	55	1	168,93
MFMELCO15	26	1	53,87	MFMELCO45	56	1	174,00
MFMELCO16	27	1	55,83	MFMELCO46	57	1	179,24
MFMELCO17	28	1	59,23	MFMELCO47	58	1	184,59
MFMELCO18	29	1	62,13	MFMELCO48	59	1	190,13
MFMELCO19	30	1	65,53	MFMELCO49	60	1	195,86
MFMELCO20	31	1	68,93	MFMELCO50	61	1	202,28
MFMELCO21	32	1	71,83	MFMELCO51	62	1	206,41
MFMELCO22	33	1	75,73	MFMELCO52	63	1	210,57
MFMELCO23	34	1	79,13	MFMELCO53	64	1	214,85
MFMELCO24	35	1	82,53	MFMELCO54	65	1	219,17
MFMELCO25	36	1	86,43	MFMELCO55	66	1	223,57
MFMELCO26	37	1	89,79	MFMELCO56	67	1	228,00
MFMELCO27	38	1	93,69	MFMELCO57	68	1	232,54
MFMELCO28	39	1	95,14	MFMELCO58	69	1	237,13
MFMELCO29	40	1	98,04	MFMELCO59	70	1	241,75
MFMELCO30	41	1	105,84				



Série curta

Código	Ø	PCS	€
MFMETI01	12	1	41,93
MFMETI02	13	1	41,93
MFMETI03	14	1	45,01
MFMETI04	15	1	46,45
MFMETI05	16	1	48,19
MFMETI06	17	1	49,75
MFMETI07	18	1	51,56
MFMETI08	19	1	54,37
MFMETI09	20	1	55,62
MFMETI10	21	1	58,30
MFMETI11	22	1	59,57
MFMETI12	23	1	66,50
MFMETI13	24	1	69,39
MFMETI14	25	1	70,78
MFMETI15	26	1	87,08
MFMETI16	27	1	87,89
MFMETI17	28	1	89,50
MFMETI18	29	1	91,92
MFMETI19	30	1	93,53
MFMETI20	31	1	108,19
MFMETI21	32	1	108,96
MFMETI22	33	1	109,96
MFMETI23	34	1	111,97
MFMETI24	35	1	112,88
MFMETI25	36	1	119,09
MFMETI26	37	1	120,81
MFMETI27	38	1	122,54
MFMETI28	39	1	124,18
MFMETI29	40	1	126,59
MFMETI30	41	1	150,08
MFMETI31	42	1	151,42
MFMETI32	43	1	152,39
MFMETI33	44	1	154,81
MFMETI34	45	1	172,55
MFMETI35	46	1	174,96
MFMETI36	47	1	177,38
MFMETI37	48	1	179,81
MFMETI38	49	1	183,03
MFMETI39	50	1	185,44
MFMETI40	55	1	288,87
MFMETI41	60	1	312,17

Série longa

Código	Ø	PCS	€
MFMELTI01	12	1	57,24
MFMELTI02	13	1	57,24
MFMELTI03	14	1	58,44
MFMELTI04	15	1	60,70
MFMELTI05	16	1	63,85
MFMELTI06	17	1	67,24
MFMELTI07	18	1	69,61
MFMELTI08	19	1	72,31
MFMELTI09	20	1	73,75
MFMELTI10	21	1	76,58
MFMELTI11	22	1	78,33
MFMELTI12	23	1	85,24
MFMELTI13	24	1	89,08
MFMELTI14	25	1	90,62
MFMELTI15	26	1	109,81
MFMELTI16	27	1	111,35
MFMELTI17	28	1	113,65
MFMELTI18	29	1	115,18
MFMELTI19	30	1	120,57
MFMELTI20	31	1	129,77
MFMELTI21	32	1	132,08
MFMELTI22	33	1	134,38
MFMELTI23	34	1	135,93
MFMELTI24	35	1	138,23
MFMELTI25	36	1	143,60
MFMELTI26	37	1	145,90
MFMELTI27	38	1	148,21
MFMELTI28	39	1	150,52
MFMELTI29	40	1	153,59
MFMELTI30	41	1	180,46
MFMELTI31	42	1	182,77
MFMELTI32	43	1	185,84
MFMELTI33	44	1	188,14
MFMELTI34	45	1	215,02
MFMELTI35	46	1	218,09
MFMELTI36	47	1	220,40
MFMELTI37	48	1	223,46
MFMELTI38	49	1	226,53
MFMELTI39	50	1	228,83
MFMELTI40	55	1	341,85
MFMELTI41	60	1	355,54



Série curta

Código	∅	PCS	€
MFMET01	12	1	39,47
MFMET02	13	1	39,47
MFMET03	14	1	39,47
MFMET04	15	1	39,47
MFMET05	16	1	39,47
MFMET06	17	1	39,47
MFMET07	18	1	39,47
MFMET08	19	1	39,47
MFMET09	20	1	39,47
MFMET10	21	1	41,18
MFMET11	22	1	41,18
MFMET12	23	1	41,18
MFMET13	24	1	41,18
MFMET14	25	1	41,18
MFMET15	26	1	47,66
MFMET16	27	1	47,66
MFMET17	28	1	47,66
MFMET18	29	1	47,66
MFMET19	30	1	47,66
MFMET20	31	1	57,20
MFMET21	32	1	57,20
MFMET22	33	1	57,20
MFMET23	34	1	57,20
MFMET24	35	1	57,20
MFMET25	36	1	65,59
MFMET26	37	1	65,59
MFMET27	38	1	65,59
MFMET28	39	1	65,59
MFMET29	40	1	65,59
MFMET30	41	1	79,70
MFMET31	42	1	79,70
MFMET32	43	1	79,70
MFMET33	44	1	79,70
MFMET34	45	1	79,70
MFMET35	46	1	85,80
MFMET36	47	1	85,80
MFMET37	48	1	85,80
MFMET38	49	1	85,80
MFMET39	50	1	89,99



Expositor acrílico

Comp.: 19 fresas
Cód.: MFMETCT01

∅	Unid.
12 x 35	1
14 x 35	1
16 x 35	1
17 x 35	1
18 x 35	1
20 x 35	1
22 x 35	1
23 x 35	1
24 x 35	1
26 x 35	1
27 x 35	1
28 x 35	1
30 x 35	1
32 x 35	1
35 x 35	1
38 x 35	1
40 x 35	1
45 x 35	1
50 x 35	1

OFERTA EXPOSITOR

966,28 €



Expositor em vidro

Comp.: 19 fresas
Cód.: MFMETCT02

∅	Unid.
12 x 35	1
14 x 35	1
16 x 35	1
17 x 35	1
18 x 35	1
20 x 35	1
22 x 35	1
23 x 35	1
24 x 35	1
26 x 35	1
27 x 35	1
28 x 35	1
30 x 35	1
32 x 35	1
35 x 35	1
38 x 35	1
40 x 35	1
45 x 35	1
50 x 35	1

+ 100€ EXPOSITOR

966,28 €

Adaptadores

Código	Descrição	€
MFMEW01	Adaptador Weldon - 18 Fein	14,99
MFMEW02	Adaptador 18 Fein - Weldon	14,99



Expulsores para fresas eletromagnéticas HSS e HSS-CO

Código	Descrição	€
MFME50	Expulsor 6,34x77mm para fresa de 30mm comp. 5,30	
MFME150	Expulsor 6,34x103mm para fresa de 50mm comp. 5,72	



Expulsores para fresas eletromagnéticas TCT

Código	Descrição	€
MFMET90	Expulsor 7,1x112mm para fresas de 12 a 16mm 18,30	
MFMET91	Expulsor 8x112mm para fresas de 17 a 50mm 18,30	



Porta fresas sem lubrificação para fresas electromagnéticas

Código	MT	L	 WELDON 19.05mm	€
MFMEW10	2	160	12 ÷ 60	145,13
MFMEW11	3	175	12 ÷ 60	145,13



Porta fresas com lubrificação para fresas electromagnéticas

Código	MT	L	 WELDON 19.05mm	€
MFMEW20	A	2	160	207,33
MFMEW21	A	3	160	207,33
MFMEW22	B	2	160	227,90
MFMEW23	B	3	160	227,90

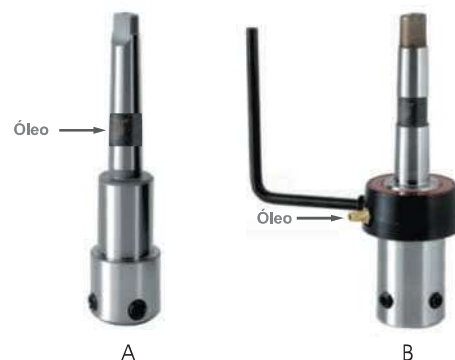

M2L (HSS+Alumínio)



Expositor acrílico

Comp.: 20 fresas
Código: MFMEE50

∅	Unid.
12 x 30	1
14 x 30	1
16 x 30	1
17 x 30	1
18 x 30	1
20 x 30	1
22 x 30	1
23 x 30	1
24 x 30	1
26 x 30	1
27 x 30	1
28 x 30	1
30 x 30	1
20 x 50	1
22 x 50	1
24 x 50	1
26 x 50	1
28 x 50	1
30 x 50	1
40 x 50	1

OFERTA EXPOSITOR

738,65 €



Mala em HSS

Comp.: 7 peças
Código: MFMEE51

∅	Unid.
12 x 30	1
14 x 30	1
16 x 30	1
18 x 30	1
20 x 30	1
22 x 30	1

1 Expulsor 6,34x77mm

OFERTA MALA

147,23 €

HSS-CO 8% (para inox)



Expositor acrílico

Comp.: 20 fresas
Cód.: MFMEECO01

∅	Unid.
12 x 30	1
14 x 30	1
16 x 30	1
17 x 30	1
18 x 30	1
20 x 30	1
22 x 30	1
23 x 30	1
24 x 30	1
26 x 30	1
27 x 30	1
28 x 30	1
30 x 30	1
20 x 50	1
22 x 50	1
24 x 50	1
26 x 50	1
28 x 50	1
30 x 50	1
40 x 50	1

OFERTA EXPOSITOR

882,17 €



Mala em HSCO 8%

Comp.: 7 peças
Cód.: MFMEECO02

∅	Unid.
12 x 30	1
14 x 30	1
16 x 30	1
18 x 30	1
20 x 30	1
22 x 30	1

1 Expulsor 6,34x77mm

OFERTA MALA

182,63 €

Código	∅	PCS	€
MFP12	12	1	10,96
MFP13	13	1	10,96
MFP14	14	1	11,20
MFP15	15	1	11,20
MFP16	16	1	11,20
MFP17	17	1	11,20
MFP18	18	1	11,20
MFP19	19	1	11,55
MFP20	20	1	12,25
MFP21	21	1	12,82
MFP22	22	1	13,40
MFP23	23	1	14,44
MFP24	24	1	14,68
MFP25	25	1	15,17
MFP26	26	1	16,19
MFP27	27	1	16,45
MFP28	28	1	17,12
MFP29	29	1	17,72
MFP30	30	1	18,04
MFP31	31	1	18,77
MFP32	32	1	19,34
MFP33	33	1	19,96
MFP34	34	1	20,66
MFP35	35	1	21,14
MFP36	36	1	22,16
MFP37	37	1	22,40
MFP38	38	1	23,00
MFP39	39	1	24,95
MFP40	40	1	24,95
MFP41	41	1	25,26
MFP42	42	1	25,79
MFP43	43	1	26,69
MFP44	44	1	27,18
MFP45	45	1	28,05
MFP46	46	1	28,29
MFP47	47	1	29,00
MFP48	48	1	30,68
MFP49	49	1	31,27
MFP50	50	1	31,27
MFP51	51	1	38,80
MFP52	52	1	39,61
MFP53	53	1	40,61
MFP54	54	1	42,17
MFP55	55	1	42,93
MFP56	56	1	43,22
MFP57	57	1	43,22
MFP58	58	1	44,90
MFP59	59	1	46,34
MFP60	60	1	46,34
MFP65	65	1	59,76
MFP70	70	1	64,10
MFP75	75	1	69,03
MFP80	80	1	77,16
MFP85	85	1	87,02
MFP90	90	1	95,72
MFP95	95	1	102,68
MFP96	100	1	111,38



Para furar inox, ferro fundido, chapa de aço e alumínio até 8mm de espessura



Expositor de fresas em acrílico

Comp.: 21 fresas	Cód.: MFJPM18 (1 fresa de cada medida)	OFERTA EXPOSITOR
∅ 18,19,20,21,22,23,24,25,26,27,28,29,30,31,32,33,34,35,36,38,40		360,99 €

Comp.: 31 fresas	Cód.: MFJPM12 (1 fresa de cada medida)	OFERTA EXPOSITOR
∅ 12,13,14,15,16,17,18,19,20,21,22,23,24,25,26,27,28,29,30,31,32,33,34,35,36,37,38,39,40, 45, 50		534,36 €



Mala de fresas

Comp.: 8 fresas	Código: MFJ001
∅	Unid.
16	1
18	1
20	1
22	1
25	1
30	1
32	1
35	1
127,82 €	

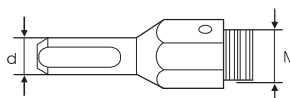

Adaptadores

Código	Descrição	∅	d	M	€
MFA12	Cabo	12 a 14	8	10 x 1,25	4,06
MFA15	Cabo	15 a 34	10	12 x 1,25	4,06
MFA50	Cabo	35 a 50	10	14 x 1,50	5,28
MFA51	Cabo	51 a 100	12	16 x 1,50	6,09
MFB12	Broca	12 a 100	6x52		1,80

Código	∅	PCS	€
MFPCO12	12	1	14,12
MFPCO13	13	1	14,12
MFPCO14	14	1	14,12
MFPCO15	15	1	14,12
MFPCO16	16	1	14,12
MFPCO17	17	1	16,14
MFPCO18	18	1	16,14
MFPCO19	19	1	17,82
MFPCO20	20	1	17,82
MFPCO21	21	1	19,82
MFPCO22	22	1	19,82
MFPCO23	23	1	22,38
MFPCO24	24	1	22,38
MFPCO25	25	1	24,59
MFPCO26	26	1	24,59
MFPCO27	27	1	26,55
MFPCO28	28	1	28,68
MFPCO29	29	1	28,68
MFPCO30	30	1	32,37
MFPCO31	31	1	32,37
MFPCO32	32	1	32,37
MFPCO33	33	1	35,19
MFPCO34	34	1	35,19
MFPCO35	35	1	38,07
MFPCO36	36	1	40,43
MFPCO37	37	1	45,53
MFPCO38	38	1	45,52
MFPCO39	39	1	45,53
MFPCO40	40	1	51,04
MFPCO41	41	1	51,04
MFPCO42	42	1	51,04
MFPCO43	43	1	51,04
MFPCO44	44	1	54,65
MFPCO45	45	1	61,36
MFPCO46	46	1	61,36
MFPCO47	47	1	64,05
MFPCO48	48	1	64,05
MFPCO49	49	1	67,41
MFPCO50	50	1	67,41
MFPCO51	51	1	80,14
MFPCO52	52	1	80,14
MFPCO53	53	1	80,14
MFPCO54	54	1	80,14
MFPCO55	55	1	80,14
MFPCO56	56	1	91,47
MFPCO57	57	1	91,47
MFPCO58	58	1	91,47
MFPCO59	59	1	91,47
MFPCO60	60	1	91,47
MFPCO65	65	1	107,60
MFPCO70	70	1	127,88
MFPCO75	75	1	148,29
MFPCO80	80	1	162,70



Para furar inox, ferro fundido, chapa de aço e alumínio até 8mm de espessura



Expositor de fresas em acrílico

Comp.: 21 fresas	Cód.: MFJPCO18 (1 fresa de cada medida)	OFERTA EXPOSITOR
∅ 18,19,20,21,22,23,24,25,26,27,28,29,30,31,32,33,34,35,36,38,40		617,33 €

Comp.: 31 fresas	Cód.: MFJPCO12 (1 fresa de cada medida)	OFERTA EXPOSITOR
∅ 12,13,14,15,16,17,18,19,20,21,22,23,24,25,26,27,28,29,30,31,32,33,34,35,36,37,38,39,40, 45, 50		897,50 €



Mala de fresas

Comp.: 8 fresas	Código: MFJ005
∅	Unid.
16	1
18	1
20	1
22	1
25	1
30	1
32	1
35	1
229,34 €	

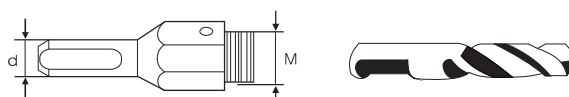

Adaptadores

Código	Descrição	∅	d	M	€
MFA12	Cabo	12 a 14	8	10 x 1,25	4,06
MFA15	Cabo	15 a 34	10	12 x 1,25	4,06
MFA50	Cabo	35 a 50	10	14 x 1,50	5,28
MFA51	Cabo	51 a 100	12	16 x 1,50	6,09
MFB12	Broca	12 a 100	6x52		1,80

Código	∅	PCS	€
MFPT12	12	1	19,98
MFPT13	13	1	19,98
MFPT14	14	1	19,98
MFPT15	15	1	19,98
MFPT16	16	1	22,01
MFPT17	17	1	22,01
MFPT18	18	1	22,01
MFPT19	19	1	22,01
MFPT20	20	1	22,01
MFPT21	21	1	24,07
MFPT22	22	1	24,07
MFPT23	23	1	26,05
MFPT24	24	1	26,05
MFPT25	25	1	26,05
MFPT26	26	1	28,05
MFPT27	27	1	28,05
MFPT28	28	1	28,05
MFPT29	29	1	28,05
MFPT30	30	1	28,94
MFPT31	31	1	28,94
MFPT32	32	1	28,94
MFPT33	33	1	28,94
MFPT34	34	1	28,94
MFPT35	35	1	28,94
MFPT36	36	1	35,10
MFPT37	37	1	35,10
MFPT38	38	1	35,10
MFPT39	39	1	39,15
MFPT40	40	1	39,15
MFPT41	41	1	43,45
MFPT42	42	1	43,45
MFPT43	43	1	45,19
MFPT44	44	1	45,19
MFPT45	45	1	47,63
MFPT46	46	1	47,63
MFPT47	47	1	47,63
MFPT48	48	1	51,28
MFPT49	49	1	51,28
MFPT50	50	1	51,28
MFPT51	51	1	56,49
MFPT52	52	1	56,49
MFPT53	53	1	56,49
MFPT54	54	1	56,49
MFPT55	55	1	56,49
MFPT56	56	1	57,43
MFPT57	57	1	57,43
MFPT58	58	1	57,43
MFPT59	59	1	57,43
MFPT60	60	1	57,43



Para furar todo o material metálico em especial aço inox até 8mm de espessura



Expositor de fresas em acrílico

Comp.: 21 fresas	Cód.: MFJPT18 (1 fresa de cada medida)	OFERTA EXPOSITOR
∅ 18,19,20,21,22,23,24,25,26,27,28,29,30,31,32,33,34,35,36,38,40		587,53 €
Comp.: 31 fresas	Cód.: MFJPT12 (1 fresa de cada medida)	OFERTA EXPOSITOR
∅ 12,13,14,15,16,17,18,19,20,21,22,23,24,25,26,27,28,29,30,31,32,33,34,35,36,37,38,39,40, 45, 50		884,64 €



Mala de fresas

Comp.: 8 fresas	Código: MFJ002
∅	Unid.
16	1
18	1
20	1
22	1
25	1
30	1
32	1
35	1
203,00 €	

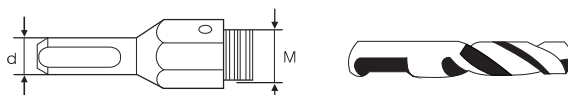

Adaptadores

Código	Descrição	∅	d	M	€
MFA12	Cabo	12 α 14	8	10 x 1,25	4,06
MFA15	Cabo	15 α 34	10	12 x 1,25	4,06
MFA50	Cabo	35 α 50	10	14 x 1,50	5,28
MFA51	Cabo	51 α 100	12	16 x 1,50	6,09
MFB12	Broca	12 α 100	6x52		1,80

Código	∅	PCS	€
MFPTI12	12	1	22,29
MFPTI13	13	1	22,29
MFPTI14	14	1	22,29
MFPTI15	15	1	22,29
MFPTI16	16	1	24,17
MFPTI17	17	1	24,17
MFPTI18	18	1	24,17
MFPTI19	19	1	25,24
MFPTI20	20	1	25,24
MFPTI21	21	1	26,21
MFPTI22	22	1	26,21
MFPTI23	23	1	28,09
MFPTI24	24	1	28,09
MFPTI25	25	1	28,09
MFPTI26	26	1	29,97
MFPTI27	27	1	29,97
MFPTI28	28	1	29,97
MFPTI29	29	1	29,97
MFPTI30	30	1	31,15
MFPTI31	31	1	31,15
MFPTI32	32	1	31,15
MFPTI33	33	1	31,15
MFPTI34	34	1	31,15
MFPTI35	35	1	31,15
MFPTI36	36	1	36,52
MFPTI37	37	1	36,52
MFPTI38	38	1	36,52
MFPTI39	39	1	40,28
MFPTI40	40	1	40,28
MFPTI41	41	1	45,12
MFPTI42	42	1	45,12
MFPTI43	43	1	46,73
MFPTI44	44	1	46,73
MFPTI45	45	1	49,41
MFPTI46	46	1	49,41
MFPTI47	47	1	49,41
MFPTI48	48	1	53,18
MFPTI49	49	1	53,18
MFPTI50	50	1	53,18
MFPTI51	51	1	55,33
MFPTI52	52	1	55,33
MFPTI53	53	1	55,33
MFPTI54	54	1	55,33
MFPTI55	55	1	55,33
MFPTI56	56	1	56,93
MFPTI57	57	1	56,93
MFPTI58	58	1	56,93
MFPTI59	59	1	56,93
MFPTI60	60	1	56,93



Para furar aço, ferro, liga leve e todo o tipo de material metálico até 8mm de espessura, especial para inox



Expositor de fresas em acrílico

Comp.: 21 fresas Cód.: MFJPTI21 (1 fresa de cada medida) OFERTA EXPOSITOR

∅ 18,19,20,21,22,23,24,25,26,27,28,29,30,31,32,33,34,35,36,38,40

631,45 €

Comp.: 31 fresas Cód.: MFJPTI31 (1 fresa de cada medida) OFERTA EXPOSITOR

∅ 12,13,14,15,16,17,18,19,20,21,22,23,24,25,26,27,28,29,30,31,32,33,34,35,36,37,38,39,40, 45, 50

948,32 €



Mala de fresas

Comp.: 8 fresas
Código: MFJ003

∅	Unid.
16	1
18	1
20	1
22	1
25	1
30	1
32	1
35	1

219,45 €

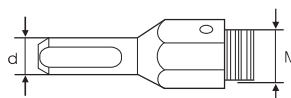

Adaptadores

Código	Descrição	∅	d	M	€
MFA12	Cabo	12 a 14	8	10 x 1,25	3,76
MFA15	Cabo	15 a 34	10	12 x 1,25	3,76
MFA50	Cabo	35 a 50	10	14 x 1,50	4,89
MFA51	Cabo	51 a 100	12	16 x 1,50	5,64
MFB12	Broca	12 a 100	6x52		1,67

Código	∅	PCS	€
MFPMD15	15	1	33,36
MFPMD16	16	1	33,36
MFPMD17	17	1	33,36
MFPMD18	18	1	33,36
MFPMD19	19	1	34,80
MFPMD20	20	1	34,80
MFPMD21	21	1	34,80
MFPMD22	22	1	34,80
MFPMD23	23	1	35,53
MFPMD24	24	1	35,53
MFPMD25	25	1	35,53
MFPMD26	26	1	41,91
MFPMD27	27	1	41,91
MFPMD28	28	1	41,91
MFPMD29	29	1	41,91
MFPMD30	30	1	41,91
MFPMD31	31	1	48,82
MFPMD32	32	1	48,82
MFPMD33	33	1	48,82
MFPMD34	34	1	48,82
MFPMD35	35	1	48,82
MFPMD36	36	1	56,57
MFPMD37	37	1	56,57
MFPMD38	38	1	56,57
MFPMD39	39	1	56,57
MFPMD40	40	1	56,57
MFPMD41	41	1	64,78
MFPMD42	42	1	64,78
MFPMD43	43	1	64,78
MFPMD44	44	1	64,78
MFPMD45	45	1	64,78
MFPMD46	46	1	75,14
MFPMD47	47	1	75,14
MFPMD48	48	1	75,14
MFPMD49	49	1	75,14
MFPMD50	50	1	75,14
MFPMD51	51	1	84,59
MFPMD52	52	1	84,59
MFPMD53	53	1	84,59
MFPMD54	54	1	84,59
MFPMD55	55	1	84,59
MFPMD56	56	1	101,51
MFPMD57	57	1	101,51
MFPMD58	58	1	101,51
MFPMD59	59	1	101,51
MFPMD60	60	1	114,08
MFPMD65	65	1	114,08
MFPMD70	70	1	137,77
MFPMD75	75	1	147,44
MFPMD80	80	1	159,53
MFPMD85	85	1	176,45
MFPMD90	90	1	190,94
MFPMD95	95	1	200,62
MFPMD100	100	1	217,54
MFPMD105	105	1	225,26
MFPMD110	110	1	251,37
MFPMD115	115	1	287,62
MFPMD120	120	1	309,38



Expositor de fresas em acrílico

Comp.: 21 fresas Cód.: MFJMD18 (1 fresa de cada medida) OFERTA EXPOSITOR

∅ 18,19,20,21,22,23,24,25,26,27,28,29,30,31,32,33,34,35,36,38,40 **902,48 €**

Comp.: 28 fresas Cód.: MFJMD15 (1 fresa de cada medida) OFERTA EXPOSITOR

∅ 15,16,17,18,19,20,21,22,23,24,25,26,27,28,29,30,31,32,33,34,35,36,37,38,39,40,45,50 **1.255,62 €**



Mala de fresas

Comp.: 8 fresas
Código: MFJ004

∅	Unid.
16	1
18	1
20	1
22	1
25	1
30	1
32	1
35	1

311,41 €

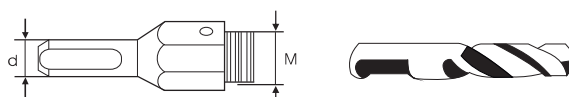

Adaptadores

Código	Descrição	∅	d	M	€	
MFAMD15	Cabo	15	α 21	10	12 x 1,50	5,80
MFAMD22	Cabo	22	α 38	10	19 x 1,50	7,04
MFAMD39	Cabo	39	α 100	13	22 x 1,50	8,70
MFB15	Broca	15	α 100	6x62		5,80
MFB105	Broca	105	α 120	8x62		8,33

**OFERTA
DA VITRINE**



Fresas p/máquinas
c/base elect. em HSS

Composição: 23 fresas

Unid.	Ø
1	12 x 30
1	13 x 30
1	14 x 30
1	15 x 30
1	16 x 30
1	17 x 30
1	18 x 30
1	19 x 30
1	20 x 30
1	21 x 30
1	22 x 30
1	23 x 30
1	24 x 30
1	25 x 30
1	26 x 30
1	27 x 30
1	28 x 30
1	29 x 30
1	30 x 30
1	32 x 30
1	35 x 30
1	38 x 30
1	40 x 30

760,57 €

Fresas perfuradoras
em HSS / TIN

Composição: 38 fresas

Unid.	Ø	Unid.	Ø
1	15	1	34
1	16	1	35
1	17	1	36
1	18	1	37
1	19	1	38
1	20	1	39
1	21	1	40
1	22	1	41
1	23	1	42
1	24	1	43
1	25	1	44
1	26	1	45
1	27	1	46
1	28	1	47
1	29	1	48
1	30	1	49
1	31	1	50
1	32	1	55
1	33	1	60

1.313,69 €

Código: MFJ013 2.074,26 €

**OFERTA
DA VITRINE**



Fresas perfuradoras em TIALN para inox

Composição: 38 fresas

Unid.	Ø	Unid.	Ø
1	15	1	34
1	16	1	35
1	17	1	36
1	18	1	37
1	19	1	38
1	20	1	39
1	21	1	40
1	22	1	41
1	23	1	42
1	24	1	43
1	25	1	44
1	26	1	45
1	27	1	46
1	28	1	47
1	29	1	48
1	30	1	49
1	31	1	50
1	32	1	55
1	33	1	60

Código: MFJ014 1.382,58 €

**OFERTA
DA VITRINE**



Fresas perfuradoras em TCT para inox

Composição: 38 fresas

Unid.	Ø	Unid.	Ø
1	15	1	34
1	16	1	35
1	17	1	36
1	18	1	37
1	19	1	38
1	20	1	39
1	21	1	40
1	22	1	41
1	23	1	42
1	24	1	43
1	25	1	44
1	26	1	45
1	27	1	46
1	28	1	47
1	29	1	48
1	30	1	49
1	31	1	50
1	32	1	55
1	33	1	60

Código: MFJ015 2.013,98 €



OFERTA DA VITRINE

Fresas p/máquinas c/base elect. em HSS

Composição: 23 fresas

Unid.	Ø
1	12 x 30
1	13 x 30
1	14 x 30
1	15 x 30
1	16 x 30
1	17 x 30
1	18 x 30
1	19 x 30
1	20 x 30
1	21 x 30
1	22 x 30
1	23 x 30
1	24 x 30
1	25 x 30
1	26 x 30
1	27 x 30
1	28 x 30
1	29 x 30
1	30 x 30
1	32 x 30
1	35 x 30
1	38 x 30
1	40 x 30

760,57 €

Serras craneanas bimetálicas em HSS-CO

Composição: 47 peças

Unid.	Ø	Unid.	Ø
2	16	1	37
2	19	1	38
2	20	1	40
2	21	1	41
2	22	1	44
2	24	1	48
2	25	1	51
2	27	1	54
2	29	1	57
2	30	1	60
1	32	1	64
1	35	1	70
		1	76

6 adaptadores GBS
6 adaptadores GBP

412,60 €

Código: MFJ016 1.173,17 €



OFERTA DA VITRINE

Fresas perfuradoras em HSS

Composição: 59 fresas

Unid.	Ø	Unid.	Ø
2	15	2	33
2	16	2	34
2	17	2	35
2	18	2	36
2	19	2	37
2	20	1	38
2	21	1	39
2	22	1	40
2	23	1	41
2	24	1	42
2	25	1	43
2	26	1	44
2	27	1	45
2	28	1	46
2	29	1	47
2	30	1	48
2	31	1	49
2	32	1	50

1.094,50 €

Fresas rotativas em Metal Duro HM-4

Composição: 45 fresas

Tipo	Ø	Unid.	Tipo	Ø	Unid.
A	6	2	E	6	1
A	8	2	E	8	1
A	10	2	E	10	1
A	12	2	E	12	1
A	16	2	E	16	1
B	6	1	F	6	1
B	8	1	F	8	1
B	10	1	F	10	1
B	12	1	F	12	1
B	16	1	F	16	1
C	6	1	G	6	1
C	8	1	G	8	1
C	10	1	G	10	1
C	12	1	G	12	1
C	16	1	G	16	1
D	6	1	H	6	1
D	8	1	H	8	1
D	10	1	H	10	1
D	12	1	H	12	1
D	16	1	H	16	1

1.127,88 €

Código: MFJ017 2.222,38 €

OFERTA DA VITRINE



Fresas perfuradoras em HSS

Composição: 59 fresas

Unid.	Ø	Unid.	Ø
2	15	2	33
2	16	2	34
2	17	2	35
2	18	2	36
2	19	2	37
2	20	1	38
2	21	1	39
2	22	1	40
2	23	1	41
2	24	1	42
2	25	1	43
2	26	1	44
2	27	1	45
2	28	1	46
2	29	1	47
2	30	1	48
2	31	1	49
2	32	1	50

1.094,50 €

Fresas p/máquinas c/base elect. em HSS

Composição: 23 fresas

Unid.	Ø
1	12 x 30
1	13 x 30
1	14 x 30
1	15 x 30
1	16 x 30
1	17 x 30
1	18 x 30
1	19 x 30
1	20 x 30
1	21 x 30
1	22 x 30
1	23 x 30
1	24 x 30
1	25 x 30
1	26 x 30
1	27 x 30
1	28 x 30
1	29 x 30
1	30 x 30
1	32 x 30
1	35 x 30
1	38 x 30
1	40 x 30

760,57 €

Código: MFJ018 1.855,07 €

OFERTA DA VITRINE



Fresas perfuradoras em TCT para inox

Composição: 38 fresas

Unid.	Ø	Unid.	Ø
1	15	1	34
1	16	1	35
1	17	1	36
1	18	1	37
1	19	1	38
1	20	1	39
1	21	1	40
1	22	1	41
1	23	1	42
1	24	1	43
1	25	1	44
1	26	1	45
1	27	1	46
1	28	1	47
1	29	1	48
1	30	1	49
1	31	1	50
1	32	1	55
1	33	1	60

2.013,98 €

Serras craneanas bimetálicas em HSS-CO

Composição: 47 peças

Unid.	Ø	Unid.	Ø
2	16	1	37
2	19	1	38
2	20	1	40
2	21	1	41
2	22	1	44
2	24	1	48
2	25	1	51
2	27	1	54
2	29	1	57
2	30	1	60
1	32	1	64
1	35	1	70
		1	76

6 adaptadores GBS
6 adaptadores GBP

412,60 €

Código: MFJ019 2.426,58 €

**OFERTA
DA VITRINE**



Serras craneanas
bimetálicas em HSS-CO

Composição: 47 peças

Unid.	Ø	Unid.	Ø
2	16	1	37
2	19	1	38
2	20	1	40
2	21	1	41
2	22	1	44
2	24	1	48
2	25	1	51
2	27	1	54
2	29	1	57
2	30	1	60
1	32	1	64
1	35	1	70
		1	76

6 adaptadores GBS
6 adaptadores GBP

412,60 €

Fresas perfuradoras
em HSS

Composição: 59 fresas

Unid.	Ø	Unid.	Ø
2	15	2	33
2	16	2	34
2	17	2	35
2	18	2	36
2	19	2	37
2	20	1	38
2	21	1	39
2	22	1	40
2	23	1	41
2	24	1	42
2	25	1	43
2	26	1	44
2	27	1	45
2	28	1	46
2	29	1	47
2	30	1	48
2	31	1	49
2	32	1	50

1.094,50 €

Código: MFJ020 1.507,01 €

HM-4

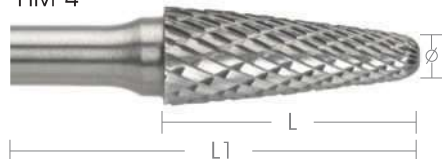

Corte cruzado:
para aço tratado, aço inox e materiais
metálicos em geral



HM-3



Corte standard:
para aço, alumínio e materiais plásticos



Código	\varnothing	L	L1	PCS	€
MFR100	6 x	18 x	50	1	14,61
MFR101	8 x	18 x	63	1	18,03
MFR102	10 x	20 x	65	1	22,37
MFR103	12 x	25 x	70	1	28,31
MFR104	16 x	25 x	70	1	42,00
MFR105	6 x	18 x	50	1	14,61
MFR106	8 x	18 x	63	1	18,03
MFR107	10 x	20 x	65	1	22,37
MFR108	12 x	25 x	70	1	28,31
MFR109	16 x	25 x	70	1	42,00
MFR110	6 x	18 x	50	1	14,61
MFR111	8 x	18 x	63	1	18,03
MFR112	10 x	20 x	65	1	22,37
MFR113	12 x	25 x	70	1	28,31
MFR114	16 x	25 x	70	1	42,00
MFR115	6 x	18 x	50	1	14,61
MFR116	8 x	18 x	63	1	18,03
MFR117	10 x	20 x	65	1	22,37
MFR118	12 x	25 x	70	1	28,31
MFR119	16 x	25 x	70	1	42,00
MFR120	6 x	18 x	50	1	14,61
MFR121	8 x	18 x	63	1	18,03
MFR122	10 x	20 x	65	1	22,37
MFR123	12 x	25 x	70	1	28,31
MFR124	16 x	25 x	70	1	42,00
MFR125	6 x	18 x	50	1	14,61
MFR126	8 x	18 x	63	1	18,03
MFR127	10 x	20 x	65	1	22,37
MFR128	12 x	25 x	70	1	28,31
MFR129	16 x	25 x	70	1	42,00
MFR130	6 x	10 x	50	1	14,61
MFR131	8 x	13 x	63	1	18,03
MFR132	10 x	16 x	65	1	22,37
MFR133	12 x	20 x	70	1	28,31
MFR134	16 x	25 x	70	1	42,00
MFR135	6 x	5 x	50	1	14,61
MFR136	8 x	7 x	63	1	18,03
MFR137	10 x	9 x	65	1	22,37
MFR138	12 x	10 x	70	1	28,31
MFR139	16 x	14 x	70	1	42,00

HM-4

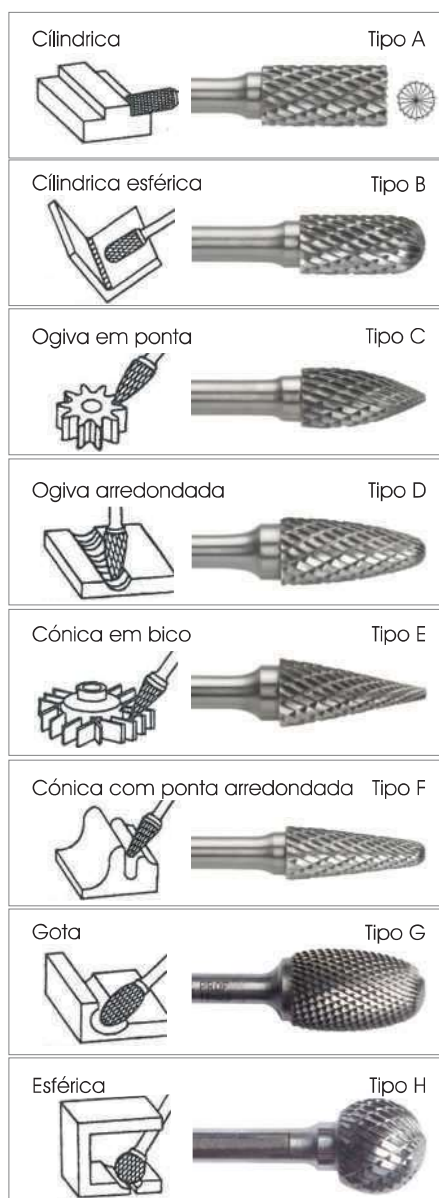

Código	\varnothing	L	L1	PCS	€
MFR140	6 x	18 x	50	1	13,24
MFR141	8 x	18 x	63	1	16,26
MFR142	10 x	20 x	65	1	20,13
MFR143	12 x	25 x	70	1	25,48
MFR144	16 x	25 x	70	1	37,80
MFR145	6 x	18 x	50	1	13,24
MFR146	8 x	18 x	63	1	16,08
MFR147	10 x	20 x	65	1	20,13
MFR148	12 x	25 x	70	1	25,48
MFR149	16 x	25 x	70	1	37,80
MFR150	6 x	18 x	50	1	13,24
MFR151	8 x	18 x	63	1	16,26
MFR152	10 x	20 x	65	1	20,13
MFR153	12 x	25 x	70	1	25,48
MFR154	16 x	25 x	70	1	37,80
MFR155	6 x	18 x	50	1	13,24
MFR156	8 x	18 x	63	1	16,26
MFR157	10 x	20 x	65	1	20,13
MFR158	12 x	25 x	70	1	25,48
MFR159	16 x	25 x	70	1	37,80
MFR160	6 x	18 x	50	1	13,24
MFR161	8 x	18 x	63	1	16,26
MFR162	10 x	20 x	65	1	20,13
MFR163	12 x	25 x	70	1	25,48
MFR164	16 x	25 x	70	1	37,80
MFR165	6 x	18 x	50	1	13,24
MFR166	8 x	18 x	63	1	16,26
MFR167	10 x	20 x	65	1	20,13
MFR168	12 x	25 x	70	1	25,48
MFR169	16 x	25 x	70	1	37,80
MFR170	6 x	10 x	50	1	13,24
MFR171	8 x	13 x	63	1	16,26
MFR172	10 x	16 x	65	1	20,13
MFR173	12 x	20 x	70	1	25,48
MFR174	16 x	25 x	70	1	37,80
MFR175	6 x	5 x	50	1	13,24
MFR176	8 x	7 x	63	1	16,26
MFR177	10 x	9 x	65	1	20,13
MFR178	12 x	10 x	70	1	25,48
MFR179	16 x	14 x	70	1	37,80



OFERTA DO EXPOSITOR

Expositor em acrílico HM4

Composição: 32 fresas Código: MFRE21

TIPO	∅	Unid.	TIPO	∅	Unid.
A	6-8-10-12	4 (1 cada)	E	6-8-10-12	4 (1 cada)
B	6-8-10-12	4 (1 cada)	F	6-8-10-12	4 (1 cada)
C	6-8-10-12	4 (1 cada)	G	6-8-10-12	4 (1 cada)
D	6-8-10-12	4 (1 cada)	H	6-8-10-12	4 (1 cada)

666,60 €



OFERTA DO EXPOSITOR

Jogos em acrílico HM4

Composição: 12 fresas Código: MFRE20

TIPO	∅	Unid.	TIPO	∅	Unid.
A	6 x 18	1	B	10 x 20	1
A	8 x 18	1	B	12 x 25	1
A	10 x 20	1	C	12 x 25	1
A	12 x 25	1	D	12 x 25	1
B	6 x 18	1	E	12 x 25	1
B	8 x 18	1	F	12 x 25	1

279,88 €



OFERTA DO EXPOSITOR

Jogos em acrílico HM4

Composição: 10 fresas Código: MFRE02

TIPO	∅	Unid.	TIPO	∅	Unid.
A	6 x 18	1	D	10 x 20	1
A	10 x 20	1	E	10 x 20	1
B	8 x 18	1	F	12 x 25	1
B	12 x 25	1	G	10 x 16	1
C	12 x 25	1	H	8 x 7	1

225,09 €



OFERTA DO EXPOSITOR

Jogos em acrílico HM3

Composição: 10 fresas Código: MFRE01

TIPO	∅	Unid.	TIPO	∅	Unid.
A	6 x 18	1	D	10 x 20	1
A	10 x 20	1	E	10 x 20	1
B	8 x 18	1	F	12 x 25	1
B	12 x 25	1	G	10 x 16	1
C	12 x 25	1	H	8 x 7	1

202,73 €

HSS

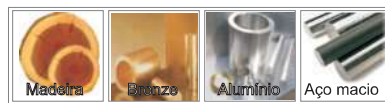

Utilização: corte de madeira ligeira, bronze, aço macio e alumínio

Código	Ø	L	PCS	€
MFR200	6 x 20	1	7,45	
MFR201	8 x 30	1	9,45	
MFR202	10 x 30	1	10,92	
MFR203	12 x 30	1	11,57	
MFR204	15 x 30	1	14,53	
MFR205	6 x 20	1	7,45	
MFR206	8 x 30	1	9,45	
MFR207	10 x 30	1	10,92	
MFR208	12 x 30	1	11,57	
MFR209	15 x 30	1	14,53	
MFR210	6 x 20	1	7,45	
MFR211	8 x 30	1	9,45	
MFR212	10 x 30	1	10,92	
MFR213	12 x 30	1	11,57	
MFR214	15 x 30	1	14,53	
MFR215	6 x 20	1	7,45	
MFR216	8 x 30	1	9,45	
MFR217	10 x 30	1	10,92	
MFR218	12 x 30	1	11,57	
MFR219	15 x 30	1	14,53	
MFR220	6 x 5	1	7,45	
MFR221	8 x 7	1	9,45	
MFR222	10 x 9	1	10,92	
MFR223	12 x 10	1	11,57	
MFR224	15 x 14	1	14,53	



OFERTA DO EXPOSITOR

Jogos em acrílico HSS

Composição: 10 fresas Código: MFRE06

TIPO	Ø	Unid.	TIPO	Ø	Unid.
A	6 x 20	1	C	10 x 30	1
A	10 x 30	1	D	6 x 20	1
B	6 x 20	1	D	10 x 30	1
B	10 x 30	1	H	6 x 5	1
C	6 x 20	1	H	10 x 9	1

91,86 €

Código	∅	Rosca	Nº dentes	Lmm	PCS	€
MFMD25	25	M-16	4	75	1	20,09
MFMD30	30	M-16	4	75	1	22,87
MFMD35	35	M-16	4	75	1	27,41
MFMD40	40	M-16	5	75	1	29,24
MFMD45	45	M-16	5	75	1	40,23
MFMD50	50	M-22	6	75	1	33,71
MFMD65	65	M-22	6	75	1	40,24
MFMD80	80	M-22	6	75	1	56,69
MFMD90	90	M-22	6	75	1	65,81
MFMD91	100	M-22	8	75	1	73,14
MFMD92	115	M-22	8	75	1	91,41
MFMD93	125	M-22	10	80	1	113,38
MFMD94	150	M-22	12	80	1	153,62



Cabo hexagonal

Código	Rosca	Lmm	PCS	€
MFAMD100	M-16	100 mm	1	8,89
MFAMD221	M-16	220 mm	1	13,14
MFAMD122	M-22	100 mm	1	8,89
MFAMD222	M-22	220 mm	1	13,14



Cabo SDS-Plus

Código	Rosca	Lmm	PCS	€
MFSDS100	M-16	100 mm	1	12,92
MFSDS220	M-16	220 mm	1	17,77
MFSDS122	M-22	100 mm	1	12,92
MFSDS222	M-22	220 mm	1	17,77



Broca

Código	Lmm	PCS	€
MFAB120	8 x 120	1	3,22



Expositor

Comp.: 24 unidades Cód.: MFEMD24

Unid.	Descrição
8	Fresas (30,35,40,50,65,80,90,100)
1	Cabo Hexagonal M16 - 100mm
1	Cabo Hexagonal M22 - 100mm
1	Cabo Hexagonal M16 - 220mm
1	Cabo Hexagonal M22 - 220mm
1	Cabo SDS M16 - 100mm
1	Cabo SDS M22 - 100mm
1	Cabo SDS M16 - 220mm
1	Cabo SDS M22 - 220mm
8	Brocas 8x120mm

Oferta do expositor 480,33 €

Código	∅	Nº dentes	Lmm	PCS	€
MFMDR01	40	5	100	1	38,37
MFMDR02	50	6	100	1	47,95
MFMDR03	60	6	100	1	69,43
MFMDR04	66	7	100	1	82,30
MFMDR05	70	8	100	1	111,88
MFMDR06	80	8	100	1	115,08
MFMDR07	90	8	100	1	125,56
MFMDR08	100	10	100	1	138,48
MFMDR09	110	12	100	1	149,95
MFMDR10	125	12	100	1	185,63
MFMDR11	150	14	100	1	223,42



Elevado rendimento e sempre desmontável graças à mola de acoplamento



Cabo SDS MAX com mola

Código	L	PCS	€
MFMAXR250	250 mm	1	46,18
MFMAXR450	450 mm	1	63,90
MFMAXR600	600 mm	1	88,80



Mola de acoplamento

Código	PCS	€
MFMDR99	1	0,71



Cunha

Código	∅	PCS	€
MFC01	9,5 x 100	1	6,00



Broca de centrar

Código	∅	PCS	€
MFMAXC12	12 x 135	1	5,30



Expositor

Comp.: 29 unidades Cód.: MFJMDR02

UNDS	Descrição
7	Fresas (40,50,60,66,80,90,100)
3	Cabo SDS MAX 250mm
3	Cabos SDS MAX 450mm
6	Brocas 12 x 135
10	Molas

Oferta do expositor 986,35 €



Macho nº1 - Cónico

Macho nº2 - 1/2 Cónico

Macho nº3 - Direito

M

DIN
352

HSS



Jogo de 3



Macho nº1 - Cónico

Macho nº3 - Direito

MF

DIN
2181

HSS



Jogo de 2

Rosca métrica HSS DIN352

Código	Medida	I mm	L mm	PCS	€
MJP550	M 2 x 0,40	10	36	3	11,89
MJP551	M 2,5 x 0,45	12	40	3	13,15
MJP552	M 3 x 0,50	12	40	3	7,57
MJP553	M 4 x 0,70	14	45	3	7,57
MJP554	M 5 x 0,80	14	50	3	8,07
MJP555	M 6 x 1,00	16	56	3	9,03
MJP578	M 7 x 1,00	19	50	3	13,35
MJP556	M 8 x 1,25	18	63	3	10,63
MJP579	M 9 x 1,25	22	63	3	15,91
MJP557	M 10 x 1,50	25	70	3	13,59
MJP558	M 12 x 1,75	30	75	3	17,51
MJP559	M 14 x 2,00	32	80	3	22,72
MJP560	M 16 x 2,00	32	80	3	26,90
MJP561	M 18 x 2,50	40	95	3	38,72
MJP562	M 20 x 2,50	40	95	3	46,59
MJP563	M 22 x 2,50	40	100	3	55,00
MJP564	M 24 x 3,00	50	110	3	64,16
MJP565	M 27 x 3,00	50	110	3	84,73
MJP566	M 30 x 3,50	50	125	3	108,36
* MJP567	M 33 x 3,50	50	132	3	136,05
* MJP568	M 36 x 4,00	56	150	3	160,49
* MJP569	M 39 x 4,00	56	150	3	259,89
* MJP570	M 42 x 4,50	63	160	3	303,76
* MJP571	M 45 x 4,50	63	160	3	386,69
* MJP572	M 48 x 5,00	68	180	3	541,18
* MJP573	M 52 x 5,00	68	180	3	556,90
* MJP574	M 56 x 5,50	85	200	3	691,33
* MJP575	M 60 x 5,50	85	200	3	876,38
* MJP576	M 64 x 6,00	90	220	3	927,88
* MJP577	M 68 x 6,00	90	220	3	1031,75

* entrega sob consulta

Rosca métrica fina DIN2181

Código	Medida	I mm	L mm	PCS	€
MJP650	M 4 x 0,50	10	45	2	12,23
MJP651	M 5 x 0,50	12	50	2	13,01
MJP652	M 6 x 0,75	14	50	2	11,21
MJP653	M 8 x 1,00	22	56	2	11,72
MJP654	M 10 x 1,00	20	63	2	15,53
MJP655	M 10 x 1,25	20	63	2	15,53
MJP656	M 12 x 1,00	22	70	2	18,40
MJP657	M 12 x 1,25	22	70	2	14,74
MJP658	M 12 x 1,50	22	70	2	14,74
MJP659	M 13 x 1,00	22	70	2	31,86
MJP660	M 14 x 1,00	22	70	2	21,92
MJP661	M 14 x 1,25	22	70	2	21,92
MJP662	M 14 x 1,50	22	70	2	18,64
MJP663	M 16 x 1,00	22	70	2	24,44
MJP664	M 16 x 1,50	22	70	2	19,85
MJP665	M 18 x 1,00	22	80	2	35,89
MJP666	M 18 x 1,50	22	80	2	29,40
MJP667	M 20 x 1,50	22	80	2	32,46
MJP668	M 20 x 2,00	22	80	2	39,97
MJP669	M 22 x 1,00	22	80	2	51,31
MJP670	M 22 x 1,50	22	80	2	51,31
MJP671	M 24 x 1,50	22	90	2	46,03
MJP672	M 24 x 2,00	22	90	2	48,20
MJP673	M 25 x 1,50	22	90	2	75,69
MJP674	M 26 x 1,50	22	90	2	71,09
MJP675	M 27 x 1,50	22	90	2	68,27
MJP676	M 27 x 2,00	22	90	2	68,27
MJP677	M 30 x 1,50	22	90	2	92,89
MJP678	M 30 x 2,00	22	90	2	92,89





Macho nº1 - Cónico



Macho nº2 - 1/2 Cónico



Macho nº3 - Direito

M

DIN
352

HSS-CO
VAPO



Rosca métrica HSS-CO para inox vapo

Código	Medida	I mm	L mm	PCS	€
MJ120	M 3 x 0,50	11	40	3	16,24
MJ121	M 4 x 0,70	13	45	3	17,79
MJ122	M 5 x 0,80	16	50	3	23,15
MJ123	M 6 x 1,00	19	50	3	23,15
MJ124	M 8 x 1,25	22	56	3	25,92
MJ125	M 10 x 1,50	24	70	3	36,12
MJ126	M 12 x 1,75	29	75	3	42,16
MJ127	M 14 x 2,00	30	80	3	45,79
MJ128	M 16 x 2,00	32	80	3	59,97
MJ129	M 18 x 2,50	40	95	3	74,82
MJ130	M 20 x 2,50	40	95	3	86,40



Macho nº1 - Cónico



Macho nº2 - 1/2 Cónico



Macho nº3 - Direito

M

DIN
352

TIN



Rosca métrica TIN para inox

Código	Medida	I mm	L mm	PCS	€
MJ150	M 3 x 0,50	11	40	3	37,43
MJ151	M 4 x 0,70	13	45	3	38,38
MJ152	M 5 x 0,80	16	50	3	39,23
MJ153	M 6 x 1,00	19	50	3	39,30
MJ154	M 8 x 1,25	22	56	3	47,23
MJ155	M 10 x 1,50	24	70	3	56,11
MJ156	M 12 x 1,75	29	75	3	86,23
MJ157	M 14 x 2,00	30	80	3	102,63
MJ158	M 16 x 2,00	32	80	3	128,15



Macho nº1 - Cónico



Macho nº2 - 1/2 Cónico



Macho nº3 - Direito

Rosca
Esquerda

DIN
352

HSS



Rosca esquerda HSS

Código	Medida	I mm	L mm	PCS	€
MJP900	M 3 x 0,50	11	40	3	11,92
MJP902	M 4 x 0,70	13	45	3	12,27
MJP904	M 5 x 0,80	16	50	3	14,52
MJP906	M 6 x 1,00	19	50	3	14,99
MJP908	M 8 x 1,25	22	56	3	16,00
MJP910	M 10 x 1,50	24	70	3	21,02
MJP912	M 12 x 1,75	29	75	3	27,98
MJP913	M 14 x 2,00	30	80	3	42,00
MJP914	M 16 x 2,00	32	80	3	46,45
MJP915	M 18 x 2,50	40	95	3	49,42
MJP916	M 20 x 2,50	40	95	3	54,52
MJP917	M 22 x 2,50	40	100	3	61,55
MJP918	M 24 x 3,00	50	110	3	77,57
MJP919	M 27 x 3,00	50	110	3	227,22
MJP920	M 30 x 3,50	56	125	3	262,20



Macho nº1 - Cónico



Macho nº2 - 1/2 Cónico



Macho nº3 - Direito

BSW

DIN
352

HSS



Rosca BSW

Código	Medida	I mm	L mm	PCS	€
MJP760	1/8 x 40	12	40	3	15,03
MJP761	5/32 x 32	14	45	3	15,03
MJP762	3/16 x 24	14	45	3	15,03
MJP775	7/32 x 24	18	50	3	15,03
MJP763	1/4 x 20	22	56	3	15,03
MJP764	5/16 x 18	22	56	3	15,87
MJP765	3/8 x 16	25	70	3	17,13
MJP766	7/16 x 14	30	75	3	22,46
MJP767	1/2 x 12	30	75	3	27,10
MJP768	9/16 x 12	32	80	3	37,63
MJP769	5/8 x 11	32	80	3	45,07
MJP770	3/4 x 10	40	95	3	60,09
MJP771	7/8 x 9	40	100	3	70,20
MJP772	1" x 8	50	110	3	70,20
MJP773	1" 1/4 x 7	56	132	3	228,80
MJP774	1" 1/2 x 6	63	150	3	332,80





GAS
BSP

DIN
5157

HSS



Rosca GAS BSP, HSS

Código	Medida	I mm	L mm	PCS	€
MJP500	G 1/8 x 28	20	63	2	13,51
MJP501	G 1/4 x 19	20	70	2	15,32
MJP502	G 3/8 x 19	22	70	2	19,81
MJP503	G 1/2 x 14	22	80	2	33,18
MJP504	G 5/8 x 14	22	80	2	50,23
MJP505	G 3/4 x 14	22	90	2	49,65
MJP506	G 7/8 x 14	22	90	2	86,17
MJP507	G 1" x 11	25	100	2	79,65
MJP508	G 1"1/8 x 11	40	125	2	117,16
MJP509	G 1"1/4 x 11	40	125	2	122,45
MJP511	G 1"1/2 x 11	40	140	2	166,46
MJP512	G 1"3/4 x 11	40	140	2	295,95
MJP513	G 2" x 11	40	160	2	295,95



UNC

DIN
352

HSS



Rosca UNC HSS

Código	Medida	I mm	L mm	PCS	€
MJP455	UNC 1/4 x 20	19	50	3	19,17
MJP456	UNC 5/16 x 18	22	56	3	20,82
MJP457	UNC 3/8 x 16	24	70	3	21,86
MJP458	UNC 7/16 x 14	24	70	3	34,75
MJP459	UNC 1/2 x 13	29	75	3	34,75
MJP460	UNC 9/16 x 12	30	80	3	48,37
MJP461	UNC 5/8 x 11	32	80	3	69,94
MJP462	UNC 3/4 x 10	40	95	3	81,17
MJP463	UNC 7/8 x 9	40	100	3	81,17
MJP464	UNC 1" x 8	50	110	3	81,17



UNF

DIN
352

HSS



Rosca UNF-SAE HSS

Código	Medida	I mm	L mm	PCS	€
MJP400	UNF 1/4 x 28	18	50	2	14,75
MJP401	UNF 5/16 x 24	22	56	2	16,02
MJP402	UNF 3/8 x 24	22	63	2	16,93
MJP403	UNF 7/16 x 20	18	63	2	22,24
MJP404	UNF 1/2 x 20	30	75	2	26,73
MJP405	UNF 9/16 x 18	32	80	2	26,73
MJP406	UNF 5/8 x 18	32	80	2	31,91
MJP407	UNF 3/4 x 16	40	95	2	42,86
MJP408	UNF 7/8 x 14	40	100	2	57,25
MJP409	UNF 1" x 12	40	100	2	57,25





Rosca métrica HSS DIN352

Medida	I mm	L mm	PCS	Código	€	Código	€	Código	€
M 2 x 0,40	10	36	1	MJPA001	3,96	MJPA025	3,96	MJPA050	3,96
M 2,5 x 0,45	12	40	1	MJPA002	4,38	MJPA026	4,38	MJPA051	4,38
M 3 x 0,50	12	40	1	MJPA003	2,82	MJPA027	2,82	MJPA052	2,82
M 4 x 0,70	14	45	1	MJPA005	2,95	MJPA029	2,95	MJPA054	2,95
M 5 x 0,80	14	50	1	MJPA006	2,96	MJPA030	2,96	MJPA055	2,96
M 6 x 1,00	16	56	1	MJPA007	3,09	MJPA031	3,09	MJPA056	3,09
M 7 x 1,00	19	50	1	MJPA008	3,41	MJPA032	3,41	MJPA057	3,41
M 8 x 1,25	18	63	1	MJPA009	3,55	MJPA033	3,55	MJPA058	3,55
M 9 x 1,25	22	63	1	MJPA010	4,26	MJPA034	4,26	MJPA059	4,26
M 10 x 1,50	25	70	1	MJPA011	4,53	MJPA035	4,53	MJPA060	4,53
M 12 x 1,75	30	75	1	MJPA013	5,83	MJPA037	5,83	MJPA062	5,83
M 14 x 2,00	32	80	1	MJPA014	7,57	MJPA038	7,57	MJPA063	7,57
M 16 x 2,00	32	80	1	MJPA015	8,96	MJPA039	8,96	MJPA064	8,96
M 18 x 2,50	40	95	1	MJPA016	14,38	MJPA040	14,38	MJPA065	14,38
M 20 x 2,50	40	95	1	MJPA017	15,53	MJPA041	15,53	MJPA066	15,53
M 22 x 2,50	40	100	1	MJPA018	18,34	MJPA042	18,34	MJPA067	18,34
M 24 x 3,00	50	110	1	MJPA019	21,38	MJPA043	21,38	MJPA068	21,38
M 27 x 3,00	50	110	1	MJPA020	28,25	MJPA044	28,25	MJPA069	28,25
M 30 x 3,50	50	125	1	MJPA021	36,12	MJPA045	36,12	MJPA070	36,12

M
DIN
352
HSS



Rosca BSW / Whitworth HSS

Medida	I mm	L mm	PCS	Código	€	Código	€	Código	€
W 1/8 x 40	12	40	1	MJPA075	5,00	MJPA095	5,00	MJPA115	5,00
W 5/32 x 32	14	45	1	MJPA076	5,00	MJPA096	5,00	MJPA116	5,00
W 3/16 x 24	14	45	1	MJPA077	5,00	MJPA097	5,00	MJPA117	5,00
W 7/32 x 24	18	50	1	MJPA078	5,00	MJPA098	5,00	MJPA118	5,00
W 1/4 x 20	22	56	1	MJPA079	5,00	MJPA099	5,00	MJPA119	5,00
W 5/16 x 18	22	56	1	MJPA080	5,28	MJPA100	5,28	MJPA120	5,28
W 3/8 x 16	25	70	1	MJPA081	5,71	MJPA101	5,71	MJPA121	5,71
W 7/16 x 14	30	75	1	MJPA082	7,49	MJPA102	7,49	MJPA122	7,49
W 1/2 x 12	30	75	1	MJPA083	9,03	MJPA103	9,03	MJPA123	9,03
W 9/16 x 12	32	80	1	MJPA084	12,54	MJPA104	12,54	MJPA124	12,54
W 5/8 x 11	32	80	1	MJPA085	15,02	MJPA105	15,02	MJPA125	15,02
W 3/4 x 10	40	95	1	MJPA086	20,03	MJPA106	20,03	MJPA126	20,03
W 7/8 x 9	40	100	1	MJPA087	23,40	MJPA107	23,40	MJPA127	23,40
W 1" x 8	50	110	1	MJPA088	23,40	MJPA108	23,40	MJPA128	23,40
W 1"1/4 x 7	56	132	1	MJPA089	76,26	MJPA109	76,26	MJPA129	76,26
W 1"1/2 x 6	63	150	1	MJPA090	110,93	MJPA110	110,93	MJPA130	110,93

BSW
DIN
352
HSS





HSS

DIN
371/376

Forma B

Navalhas direitas DIN371/376 HSS

Código	Medida	I mm	L mm	PCS	€
DIN371					
MJP600	M 3 x 0,50	11	56	1	3,92
MJP601	M 4 x 0,70	13	63	1	3,92
MJP602	M 5 x 0,80	16	70	1	4,25
MJP603	M 6 x 1,00	19	80	1	4,25
MJP604	M 8 x 1,25	22	90	1	5,27
MJP605	M 10 x 1,50	24	100	1	6,86
DIN376					
MJP606	M 12 x 1,75	29	110	1	9,50
MJP607	M 14 x 2,00	30	110	1	11,35
MJP608	M 16 x 2,00	32	110	1	11,56
MJP609	M 18 x 2,50	34	125	1	16,09
MJP610	M 20 x 2,50	34	140	1	21,28
MJP611	M 22 x 2,50	34	140	1	25,58
MJP612	M 24 x 3,00	38	160	1	33,18
MJP613	M 27 x 3,00	45	135	1	47,01
MJP614	M 30 x 3,50	48	138	1	60,63



HSS

DIN
371/376

Forma B
35°

Navalhas helicoidais DIN371/376 HSS

Código	Medida	I mm	L mm	PCS	€
DIN371					
MJP720	M 3 x 0,50	11	56	1	6,66
MJP721	M 4 x 0,70	13	63	1	6,66
MJP722	M 5 x 0,80	16	70	1	6,77
MJP723	M 6 x 1,00	19	80	1	6,77
MJP724	M 8 x 1,25	22	90	1	8,03
MJP725	M 10 x 1,50	24	100	1	9,21
DIN376					
MJP726	M 12 x 1,75	29	110	1	10,93
MJP727	M 14 x 2,00	30	110	1	14,02
MJP728	M 16 x 2,00	32	110	1	15,82
MJP729	M 18 x 2,50	34	125	1	21,50
MJP730	M 20 x 2,50	34	140	1	26,99

Jogo de machos para máquina
navalhas direitas DIN371/376 HSS

HSS

DIN
371/376

Forma B



Comp.: 7 machos (1 de cada medida) Código: MJP690

∅ M3 - M4 - M5 - M6 - M8 - M10 - M12 40,16 €

Jogo de machos para máquina
navalhas helicoidais DIN371/376 HSS

HSS

DIN
371/376

Forma B
35°



Comp.: 7 machos (1 de cada medida) Código: MJP691

∅ M3, M4, M5, M6, M8, M10, M12 72,07 €





Navalhas direitas DIN371/376 HSS-CO

Código	Medida	I mm	L mm	PCS	€
DIN371					
MMP001	M 3 x 0,50	11	56	1	5,89
MMP002	M 4 x 0,70	13	63	1	5,89
MMP003	M 5 x 0,80	16	70	1	7,10
MMP004	M 6 x 1,00	19	80	1	8,94
MMP005	M 8 x 1,25	22	90	1	10,49
MMP006	M 10 x 1,50	24	100	1	14,50
DIN376					
MMP007	M 12 x 1,75	29	110	1	17,23
MMP008	M 14 x 2,00	30	110	1	17,62
MMP009	M 16 x 2,00	32	110	1	22,35
MMP010	M 18 x 2,50	34	125	1	24,85
MMP011	M 20 x 2,50	34	140	1	27,70
MMP012	M 22 x 2,50	34	140	1	33,55
MMP013	M 24 x 3,00	38	160	1	42,58
MMP014	M 27 x 3,00	38	160	1	69,13
MMP015	M 30 x 3,50	48	180	1	84,36



Navalhas helicoidais DIN371/376 HSS-CO

Código	Medida	I mm	L mm	PCS	€
DIN371					
MMP016	M 3 x 0,50	11	56	1	6,98
MMP017	M 4 x 0,70	13	63	1	6,98
MMP018	M 5 x 0,80	16	70	1	7,70
MMP019	M 6 x 1,00	19	80	1	9,66
MMP020	M 8 x 1,25	22	90	1	12,59
MMP021	M 10 x 1,50	24	100	1	17,02
DIN376					
MMP022	M 12 x 1,75	29	110	1	19,82
MMP023	M 14 x 2,00	30	110	1	19,94
MMP024	M 16 x 2,00	32	110	1	25,41
MMP025	M 18 x 2,50	34	125	1	28,26
MMP026	M 20 x 2,50	34	140	1	31,47

Jogo de machos para máquina navalhas direitas DIN371/376 HSS-CO



HSS-CO

DIN 371/376

Forma B

Comp.: 7 machos (1 de cada medida) Código: MJCM01

∅ M3 - M4 - M5 - M6 - M8 - M10 - M12 72,08 €

Jogo de machos para máquina navalhas helicoidais DIN371/376 HSS-CO



HSS-CO

DIN 371/376

Forma B 35°

Comp.: 7 machos (1 de cada medida) Código: MJCM02

∅ M3, M4, M5, M6, M8, M10, M12 80,60 €





Rosca BSW / Whitworth nav. direitas HSS-CO

Rosca métrica, navalhas direitas - TIN

Código	Medida	I mm	L mm	PCS	€
DIN371					
MMP100	W 1/8 x 40	11	56	1	21,24
MMP101	W 5/32 x 32	13	63	1	21,24
MMP102	W 3/16 x 24	15	70	1	21,79
MMP103	W 1/4 x 20	17	80	1	21,79
MMP104	W 5/16 x 18	20	90	1	26,84
MMP105	W 3/8 x 16	22	100	1	30,14
DIN376					
MMP106	W 7/16 x 14	22	100	1	32,47
MMP107	W 1/2 x 12	24	110	1	32,78
MMP108	W 9/16 x 12	26	110	1	48,46
MMP109	W 5/8 x 11	27	110	1	48,46
MMP110	W 3/4 x 10	30	125	1	100,40
MMP111	W 7/8 x 9	32	140	1	113,41
MMP112	W 1" x 8	36	160	1	128,80

Código	Medida	I mm	L mm	PCS	€
DIN371					
MMT01	M 3 x 0,50	10	56	1	14,17
MMT02	M 4 x 0,70	12	63	1	14,17
MMT03	M 5 x 0,80	14	70	1	14,84
MMT04	M 6 x 1,00	19	80	1	14,84
MMT05	M 8 x 1,25	22	90	1	16,58
MMT06	M 10 x 1,50	24	100	1	20,93
DIN376					
MMT07	M 12 x 1,75	29	110	1	21,73
MMT08	M 14 x 2,00	26	110	1	47,87
MMT09	M 16 x 2,00	27	110	1	54,34
MMT10	M 18 x 2,50	30	125	1	65,92
MMT11	M 20 x 2,50	32	140	1	74,67

Jogo de machos para máquina rosca BSW, navalhas direitas em HSS-CO

Jogo de machos para máquina rosca métrica, navalhas direitas em TIN



Comp.: 7 machos (1 de cada medida) Código: MJCM10
 Ø 1/8 - 5/32 - 3/16 - 1/4 - 5/16 - 3/8 - 7/16 112,39 €

Comp.: 7 machos (1 de cada medida) Código: MJCM20
 Ø M 3, M 4, M 5, M 6, M 8, M 10, M 12 127,26 €



Machos para máquina com anel de cor



Nome	Aço Construção $\leq 500 \text{ N/mm}^2$	Aço Construção $> 500 \text{ N/mm}^2$	Aço $\leq 1000 \text{ N/mm}^2$	Aço Temperado $\leq 1000 \text{ N/mm}^2$	Liga Aço $\leq 1200 \text{ N/mm}^2$
Forma B	●	●	●	○	
35°	●	●	●	○	
Broca Macho	●	○			
Forma B	●	●	●	●	●
35°	●	●	●	●	●
Forma B VAP					
35° / VAP					

Machos para máquina especiais



Forma B				●	●
Forma B				●	●
Forma B - AZ	●	●			
Laminação					

● Recomendado ○ Adequado

Aços Duros 40 60 HRC ² ≤ 850 N/mm ²	Aço de Ferramenta ≤ 1000 N/mm ²	Fundição ≤ 300 HB	Cobre ≤ 400 N/mm	Liga Alumínio ≤ 450 N/mm	Óleo de Corte	Óleo Solúvel	Lubrificação mínima	Trabalho a Seco	Pág.
	○		○	○	●	●	●		117
	○		○	○	●	●	●		117
○		○		●	●				122
	●				●	●	●		119
	●				●	●	●		119
●					●	●	●		118
●					●	●	●		118

	●				●	●	●		113
	●						●	●	120
		●	●		●				120
			●	●	●	●			120



HSS-CO

DIN
5156

Forma B

Rosca BSP (GAS) navalhas direitas HSS-CO

Código	Medida	I mm	L mm	PCS	€
MMP050	G 1/8 x 28	20	90	1	16,02
MMP051	G 1/4 x 19	20	100	1	18,54
MMP052	G 3/8 x 19	22	100	1	22,53
MMP053	G 1/2 x 14	25	140	1	37,85
MMP054	G 5/8 x 14	25	140	1	38,48
MMP055	G 3/4 x 14	30	140	1	56,73
MMP056	G 7/8 x 14	30	160	1	58,18
MMP057	G 1" x 11	36	160	1	83,98
MMP058	G 1"1/8 x 11	30	170	1	183,37
MMP059	G 1"1/4 x 11	30	170	1	207,56
MMP060	G 1"1/2 x 11	32	190	1	307,60



HSS-CO

DIN
5156

Forma B
35°

Rosca BSP (GAS) nav. helicoidais HSS-CO

Código	Medida	I mm	L mm	PCS	€
MMP070	G 1/8 x 28	20	90	1	18,61
MMP071	G 1/4 x 19	20	100	1	21,72
MMP072	G 3/8 x 19	22	100	1	26,38
MMP073	G 1/2 x 14	25	140	1	44,18
MMP074	G 5/8 x 14	25	140	1	44,58
MMP075	G 3/4 x 14	30	140	1	66,07
MMP076	G 7/8 x 14	30	160	1	76,07
MMP077	G 1" x 11	36	160	1	97,65
MMP078	G 1"1/8 x 11	30	170	1	206,47
MMP079	G 1"1/4 x 11	30	170	1	241,88
MMP080	G 1"1/2 x 11	32	190	1	420,56





Navalhas direitas DIN371/376 HSS-CO

Navalhas helicoidais DIN371/376 HSS-CO

Código	Medida	I mm	L mm	PCS	€
DIN371					
MMP201	M 3 x 0,50	11	56	1	10,31
MMP202	M 4 x 0,70	13	63	1	10,31
MMP203	M 5 x 0,80	16	70	1	10,77
MMP204	M 6 x 1,00	19	80	1	10,77
MMP205	M 8 x 1,25	22	90	1	13,25
MMP206	M 10 x 1,50	24	100	1	15,04
DIN376					
MMP207	M 12 x 1,75	29	110	1	17,40
MMP208	M 14 x 2,00	30	110	1	24,89
MMP209	M 16 x 2,00	32	110	1	28,34
MMP210	M 18 x 2,50	34	125	1	38,94
MMP211	M 20 x 2,50	34	140	1	54,43
MMP212	M 22 x 2,50	34	140	1	60,54
MMP213	M 24 x 3,00	38	160	1	64,11
MMP214	M 27 x 3,00	38	160	1	76,49
MMP215	M 30 x 3,50	48	180	1	79,49

Código	Medida	I mm	L mm	PCS	€
DIN371					
MMP250	M 3 x 0,50	11	56	1	12,39
MMP251	M 4 x 0,70	13	63	1	12,39
MMP252	M 5 x 0,80	16	70	1	12,91
MMP253	M 6 x 1,00	19	80	1	12,91
MMP254	M 8 x 1,25	22	90	1	15,79
MMP255	M 10 x 1,50	24	100	1	18,26
DIN376					
MMP256	M 12 x 1,75	29	110	1	18,95
MMP257	M 14 x 2,00	30	110	1	27,25
MMP258	M 16 x 2,00	32	110	1	28,80
MMP259	M 18 x 2,50	34	125	1	42,57
MMP260	M 20 x 2,50	34	140	1	59,97

Jogo de machos para máquina navalhas direitas DIN371/376 HSS-CO

Jogo de machos para máquina navalhas helicoidais DIN371/376 HSS-CO

USO UNIVERSAL < 1000 N/mm²

USO UNIVERSAL < 1000 N/mm²



Comp.: 7 machos (1 de cada medida) Código: MMP270
 Ø M3 - M4 - M5 - M6 - M8 - M10 - M12 144,37 €

Comp.: 7 machos (1 de cada medida) Código: MMP271
 Ø M3, M4, M5, M6, M8, M10, M12 155,00 €

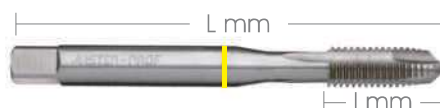



Navalhas direitas HSS-CO - VAPO

Código	Medida	I mm	L mm	PCS	€
DIN371					
MMI01	M 3 x 0,50	11	56	1	12,25
MMI02	M 4 x 0,70	13	63	1	12,25
MMI03	M 5 x 0,80	16	70	1	13,18
MMI04	M 6 x 1,00	19	80	1	13,18
MMI05	M 8 x 1,25	22	90	1	15,19
MMI06	M 10 x 1,50	24	100	1	16,12
DIN376					
MMI07	M 12 x 1,75	29	110	1	17,88
MMI08	M 14 x 2,00	30	110	1	25,57
MMI09	M 16 x 2,00	32	110	1	29,07
MMI10	M 18 x 2,50	34	125	1	37,23
MMI11	M 20 x 2,50	34	140	1	55,94

Navalhas helicoidais HSS-CO - VAPO

Código	Medida	I mm	L mm	PCS	€
DIN371					
MMI15	M 3 x 0,50	11	56	1	12,73
MMI16	M 4 x 0,70	13	63	1	12,73
MMI17	M 5 x 0,80	16	70	1	13,26
MMI18	M 6 x 1,00	19	80	1	13,26
MMI19	M 8 x 1,25	22	90	1	16,22
MMI20	M 10 x 1,50	24	100	1	18,76
DIN376					
MMI21	M 12 x 1,75	29	110	1	19,48
MMI22	M 14 x 2,00	30	110	1	28,00
MMI23	M 16 x 2,00	32	110	1	29,60
MMI24	M 18 x 2,50	34	125	1	43,75
MMI25	M 20 x 2,50	34	140	1	61,63

Jogo de machos para máquina para trabalhos especiais, navalhas direitas HSS-CO - VAPO

Jogo de machos para máquina para trabalhos especiais, navalhas helicoidais HSS-CO - VAPO



Comp.: 7 machos (1 de cada medida) Código: MMI90
 Ø M3 - M4 - M5 - M6 - M8 - M10 - M12 99,57 €

Comp.: 7 machos (1 de cada medida) Código: MMI91
 Ø M3, M4, M5, M6, M8, M10, M12 141,43 €





Rosca métrica navalhas direitas HSS-CO

Rosca métrica navalhas helicoidais HSS-CO

Código	Medida	L mm	L mm	PCS	€
DIN371					
MMA30	M 3 x 0,50	11	56	1	11,17
MMA31	M 4 x 0,70	13	63	1	11,17
MMA32	M 5 x 0,80	16	70	1	11,67
MMA33	M 6 x 1,00	19	80	1	11,67
MMA34	M 8 x 1,25	22	90	1	14,35
MMA35	M 10 x 1,50	24	100	1	16,29
DIN376					
MMA36	M 12 x 1,75	29	110	1	18,84
MMA37	M 14 x 2,00	30	110	1	26,96
MMA38	M 16 x 2,00	32	110	1	30,64
MMA39	M 18 x 2,50	34	125	1	33,01
MMA40	M 20 x 2,50	34	140	1	58,97

Código	Medida	L mm	L mm	PCS	€
DIN371					
MMA50	M 3 x 0,50	11	56	1	13,42
MMA51	M 4 x 0,70	13	63	1	13,42
MMA52	M 5 x 0,80	16	70	1	13,98
MMA53	M 6 x 1,00	19	80	1	13,98
MMA54	M 8 x 1,25	22	90	1	17,10
MMA55	M 10 x 1,50	24	100	1	19,78
DIN376					
MMA56	M 12 x 1,75	29	110	1	20,53
MMA57	M 14 x 2,00	30	110	1	29,52
MMA58	M 16 x 2,00	32	110	1	31,20
MMA59	M 18 x 2,50	34	125	1	46,11
MMA60	M 20 x 2,50	34	140	1	64,96

Jogo de machos para máquina para trabalhos especiais, rosca métrica, navalhas direitas HSS-CO

Jogo de machos para máquina para trabalhos especiais, rosca métrica, navalhas helicoidais HSS-CO

MATERIAIS DUROS <math>< 1000 \text{ N/mm}^2</math>

MATERIAIS DUROS <math>< 1000 \text{ N/mm}^2</math>



Comp.: 7 machos (1 de cada medida) Código: MMA90
 Ø M3 - M4 - M5 - M6 - M8 - M10 - M12 96,89 €

Comp.: 7 machos (1 de cada medida) Código: MMA91
 Ø M3, M4, M5, M6, M8, M10, M12 112,61 €





HSS-CO
TIALN

DIN
371/376

Forma B

Navalhas direitas HSS-CO - TIALN

Código	Medida	I mm	L mm	PCS	€
DIN371					
MMTIO1	M 3 x 0,50	11	56	1	11,85
MMTIO2	M 4 x 0,70	13	63	1	12,19
MMTIO3	M 5 x 0,80	16	70	1	12,66
MMTIO4	M 6 x 1,00	19	80	1	12,66
MMTIO5	M 8 x 1,25	22	90	1	15,18
MMTIO6	M 10 x 1,50	24	100	1	17,70
DIN376					
MMTIO7	M 12 x 1,75	29	110	1	20,56
MMTIO8	M 14 x 2,00	30	110	1	29,41
MMTIO9	M 16 x 2,00	32	110	1	33,35
MMTIO10	M 18 x 2,50	34	125	1	46,02
MMTIO11	M 20 x 2,50	34	140	1	64,32



HSS-CO

DIN
371/376

Forma B
AZ

Rosca alternada para alumínio HSS-CO

Código	Medida	I mm	L mm	PCS	€
DIN371					
MMA01	M 3 x 0,50	11	56	1	12,51
MMA02	M 4 x 0,70	13	63	1	13,37
MMA03	M 5 x 0,80	16	70	1	14,27
MMA04	M 6 x 1,00	19	80	1	15,15
MMA05	M 8 x 1,25	22	90	1	16,89
MMA06	M 10 x 1,50	24	100	1	19,13
DIN376					
MMA07	M 12 x 1,75	29	110	1	19,81
MMA08	M 14 x 2,00	30	110	1	28,52
MMA09	M 16 x 2,00	32	110	1	30,18
MMA10	M 18 x 2,50	34	125	1	44,56
MMA11	M 20 x 2,50	34	140	1	62,90



HSS-CO
Nitrato
Titânio

DIN
371/376

Laminação HSS-CO, Nitrato Titânio

Código	Medida	I mm	L mm	PCS	€
DIN371					
MMLA01	M 3 x 0,50	10	56	1	12,32
MMLA02	M 4 x 0,70	12	63	1	12,32
MMLA03	M 5 x 0,80	14	70	1	12,91
MMLA04	M 6 x 1,00	19	80	1	12,91
MMLA05	M 8 x 1,25	22	90	1	15,79
MMLA06	M 10 x 1,50	24	100	1	18,20
DIN376					
MMLA07	M 12 x 1,75	29	110	1	18,90
MMLA08	M 14 x 2,00	30	110	1	52,63
MMLA09	M 16 x 2,00	32	110	1	61,00
MMLA10	M 18 x 2,50	34	125	1	61,26





HSS-CO	DIN 374/B	ISO 2/6 H
--------	--------------	--------------

Código	Medida	I mm	L mm	PCS	€
MM001	MF 3 x 0,35	9	56	1	19,95
MM002	MF 4 x 0,35	10	63	1	19,95
MM003	MF 4 x 0,50	10	63	1	17,40
MM004	MF 5 x 0,50	12	70	1	17,40
MM005	MF 5 x 0,75	12	70	1	19,95
MM006	MF 6 x 0,50	14	80	1	17,89
MM007	MF 6 x 0,75	14	80	1	17,89
MM008	MF 7 x 0,75	14	80	1	24,62
MM009	MF 8 x 0,50	19	80	1	28,40
MM010	MF 8 x 0,75	19	80	1	23,08
MM011	MF 8 x 1,00	22	90	1	20,20
MM012	MF 9 x 0,75	19	80	1	26,95
MM013	MF 9 x 1,00	22	90	1	24,62
MM014	MF 10 x 0,75	20	90	1	23,52
MM015	MF 10 x 1,00	20	90	1	23,52
MM016	MF 10 x 1,25	24	100	1	23,52
MM017	MF 11 x 1,00	20	90	1	33,33
MM018	MF 11 x 1,25	22	90	1	33,33
MM019	MF 12 x 0,75	22	100	1	33,33
MM020	MF 12 x 1,00	22	100	1	27,46
MM021	MF 12 x 1,25	22	100	1	27,46
MM022	MF 12 x 1,50	22	100	1	27,46
MM023	MF 13 x 1,00	22	100	1	39,03
MM024	MF 13 x 1,50	22	100	1	39,03
MM025	MF 14 x 0,75	22	100	1	39,03
MM026	MF 14 x 1,00	22	100	1	39,03
MM027	MF 14 x 1,25	22	100	1	39,03
MM028	MF 14 x 1,50	22	100	1	36,60
MM029	MF 15 x 1,00	22	100	1	39,03
MM030	MF 15 x 1,50	22	100	1	39,03
MM031	MF 16 x 1,00	22	100	1	39,03
MM032	MF 16 x 1,25	22	100	1	39,03
MM033	MF 16 x 1,50	22	100	1	36,60
MM034	MF 18 x 1,00	25	110	1	46,98
MM035	MF 18 x 1,25	25	110	1	46,98
MM036	MF 18 x 1,50	25	110	1	46,98
MM037	MF 18 x 2,00	34	125	1	46,98
MM038	MF 20 x 1,00	25	125	1	50,11
MM039	MF 20 x 1,25	25	125	1	50,11
MM040	MF 20 x 1,50	25	125	1	50,11
MM041	MF 20 x 2,00	34	140	1	50,11
MM042	MF 21 x 1,50	25	125	1	67,85
MM043	MF 22 x 1,00	25	125	1	67,85
MM044	MF 22 x 1,25	25	125	1	67,85
MM045	MF 22 x 1,50	25	125	1	67,85
MM046	MF 22 x 2,00	34	140	1	67,85
MM047	MF 23 x 1,50	25	125	1	90,62
MM048	MF 24 x 1,00	28	140	1	78,32
MM049	MF 24 x 1,25	28	140	1	78,32
MM050	MF 24 x 1,50	28	140	1	78,32
MM051	MF 24 x 2,00	28	140	1	78,32

Código	Medida	I mm	L mm	PCS	€
MM052	MF 25 x 1,00	28	140	1	90,62
MM053	MF 25 x 1,50	28	140	1	90,62
MM054	MF 26 x 1,00	28	140	1	89,85
MM055	MF 26 x 1,50	28	140	1	89,85
MM056	MF 26 x 2,00	28	140	1	89,85
MM057	MF 27 x 1,00	28	140	1	96,75
MM058	MF 27 x 1,50	28	140	1	96,75
MM059	MF 27 x 2,00	28	140	1	96,75
MM060	MF 28 x 1,00	28	140	1	96,75
MM061	MF 28 x 1,50	28	140	1	96,75
MM062	MF 28 x 2,00	28	140	1	96,75
MM063	MF 29 x 1,50	28	150	1	130,54
MM064	MF 30 x 1,00	28	150	1	112,11
MM065	MF 30 x 1,50	28	150	1	112,11
MM066	MF 30 x 2,00	28	150	1	112,11
MM067	MF 30 x 2,50	45	180	1	125,16
MM068	MF 30 x 3,00	45	180	1	125,16
MM069	MF 32 x 1,50	28	150	1	140,52
MM070	MF 32 x 2,00	28	150	1	140,52
MM071	MF 32 x 3,00	50	180	1	140,52
MM072	MF 33 x 1,50	30	160	1	156,66
MM073	MF 33 x 2,00	30	160	1	156,66
MM074	MF 33 x 3,00	50	180	1	156,66
MM075	MF 34 x 1,50	30	170	1	159,72
MM076	MF 34 x 2,00	30	170	1	159,72
MM077	MF 35 x 1,50	30	170	1	166,64
MM078	MF 36 x 1,50	30	170	1	166,64
MM079	MF 36 x 2,00	30	170	1	166,64
MM080	MF 36 x 3,00	56	200	1	166,64
MM081	MF 38 x 1,50	30	170	1	178,15
MM082	MF 39 x 1,50	30	170	1	178,15
MM083	MF 39 x 2,00	30	170	1	178,15
MM084	MF 39 x 3,00	60	200	1	178,15
MM085	MF 40 x 1,50	30	170	1	192,74
MM086	MF 40 x 2,00	30	170	1	192,74
MM087	MF 40 x 3,00	60	200	1	192,74
MM088	MF 42 x 1,50	30	170	1	229,60
MM089	MF 42 x 2,00	30	170	1	229,60
MM090	MF 42 x 3,00	60	200	1	229,60
MM091	MF 45 x 1,50	32	180	1	255,72
MM092	MF 45 x 2,00	32	180	1	255,72
MM093	MF 45 x 3,00	50	200	1	255,72
MM094	MF 48 x 1,50	32	190	1	304,87
MM095	MF 48 x 2,00	32	190	1	304,87
MM096	MF 48 x 3,00	50	225	1	304,87
MM097	MF 50 x 1,50	32	190	1	359,38
MM098	MF 50 x 2,00	32	190	1	359,38
MM099	MF 50 x 3,00	50	225	1	359,38
MM100	MF 52 x 1,50	32	190	1	391,63
MM101	MF 52 x 2,00	32	190	1	391,63
MM102	MF 52 x 3,00	50	225	1	391,63
MM103	MF 63 x 1,50	50	275	1	690,35

* Navalhas helicoidais sob consulta



Broca - Macho HSS-CO (2 em 1)

Broca - Macho - Escareador HSS (3 em 1)

Código	Medida	I mm	M mm	L mm	PCS	€
MMB01	M 3 x 0,50	16	11	56	1	22,29
MMB02	M 4 x 0,70	18	14	63	1	22,29
MMB03	M 5 x 0,80	20	18	71	1	22,29
MMB04	M 6 x 1,00	22	22	80	1	25,17
MMB05	M 8 x 1,25	26	25	95	1	28,05
MMB06	M 10 x 1,50	30	31	106	1	30,88
MMB07	M 12 x 1,75	32	35	115	1	41,41

Código	Medida	I mm	L mm	PCS	€
MTX100	3 x 0,50	2,50	36	1	8,28
MTX101	4 x 0,70	3,30	39	1	8,28
MTX102	5 x 0,80	4,20	41	1	8,28
MTX103	6 x 1,00	5,00	44	1	8,28
MTX104	8 x 1,25	6,80	50	1	9,44
MTX105	10 x 1,50	8,50	59	1	9,44



Macho - Bit

Código	Medida	I mm	L mm	PCS	€
MMB20	3 x 0,50	2,50	33	1	6,09
MMB21	4 x 0,70	3,30	35	1	6,24
MMB22	5 x 0,80	4,20	36	1	6,83
MMB23	6 x 1,00	5,00	39	1	7,13
MMB24	8 x 1,25	6,80	40	1	9,21
MMB25	10 x 1,50	8,50	41	1	11,29

Jogo macho - bit

Comp.: 6 machos
(1 de cada medida)
Código: MMB29

Ø M 3, M 4, M 5
M 6, M 8, M 10

50,51 €



Conta fios métrico ISO 60° - Wh 55°

Código	Descrição	PCS	€
MMB99	52 pcs ISO 0,25 + 6	1	13,52





HSS

DIN
223

Rosca métrica fina HSS

Código	Medida	∅	PCS	€
MCF01	MF 3 X 0,35	20	1	12,68
MCF02	MF 4 x 0,35	20	1	19,93
MCF03	MF 4 x 0,50	20	1	12,68
MCF04	MF 5 x 0,50	20	1	12,68
MCF05	MF 5 x 0,75	20	1	17,32
MCF06	MF 6 x 0,50	20	1	17,32
MCF07	MF 7 x 0,75	25	1	17,32
MCF08	MF 8 x 0,50	25	1	17,32
MCF09	MF 8 x 0,75	25	1	13,80
MCF10	MF 9 x 0,75	25	1	30,41
MCF11	MF 9 x 1,00	25	1	18,78
MCF12	MF 10 x 0,75	30	1	16,53
MCF13	MF 11 x 1,00	30	1	22,73
MCF14	MF 11 x 1,25	30	1	22,73
MCF15	MF 12 x 0,75	38	1	29,87
MCF16	MF 13 x 1,00	38	1	31,45
MCF17	MF 13 x 1,50	38	1	31,45
MCF18	MF 14 x 0,75	38	1	38,60
MCF19	MF 15 x 1,00	38	1	50,22
MCF20	MF 15 x 1,50	38	1	36,37
MCF21	MF 16 x 1,25	45	1	41,17
MCF22	MF 18 x 1,25	45	1	50,22
MCF23	MF 18 x 2,00	45	1	33,34
MCF24	MF 20 x 1,00	45	1	35,36
MCF25	MF 20 x 1,25	45	1	35,36
MCF26	MF 21 x 1,50	45	1	59,90
MCF27	MF 22 x 1,00	55	1	55,45
MCF28	MF 22 x 1,25	55	1	55,45
MCF29	MF 22 x 2,00	55	1	51,82
MCF30	MF 23 x 1,50	55	1	107,82
MCF31	MF 24 x 1,00	55	1	56,44
MCF32	MF 24 x 1,25	55	1	56,44
MCF33	MF 25 x 1,00	55	1	78,32
MCF34	MF 26 x 1,00	55	1	97,86
MCF35	MF 26 x 1,50	55	1	97,86
MCF36	MF 26 x 2,00	55	1	97,86
MCF37	MF 27 x 1,00	65	1	110,76
MCF38	MF 27 x 1,50	65	1	110,76
MCF39	MF 28 x 1,00	65	1	110,76
MCF40	MF 28 x 1,50	65	1	110,76
MCF41	MF 28 x 2,00	65	1	110,76

Rosca métrica fina HSS

Código	Medida	∅	PCS	€
MCF42	MF 29 x 1,50	65	1	110,76
MCF43	MF 30 x 1,00	65	1	110,76
MCF44	MF 30 x 2,50	65	1	110,76
MCF45	MF 30 x 3,00	65	1	110,76
MCF46	MF 32 x 1,50	65	1	109,69
MCF47	MF 32 x 2,00	65	1	109,69
MCF48	MF 32 x 3,00	65	1	109,69
MCF49	MF 33 x 1,50	65	1	125,16
MCF50	MF 33 x 2,00	65	1	125,16
MCF51	MF 33 x 3,00	65	1	125,16
MCF52	MF 34 x 1,50	65	1	125,16
MCF53	MF 34 x 2,00	65	1	125,16
MCF54	MF 35 x 1,50	65	1	131,31
MCF55	MF 36 x 1,50	65	1	131,31
MCF56	MF 36 x 2,00	65	1	131,31
MCF57	MF 36 x 3,00	65	1	131,31
MCF58	MF 38 x 1,50	75	1	195,67
MCF59	MF 39 x 1,50	75	1	194,90
MCF60	MF 39 x 2,00	75	1	194,90
MCF61	MF 39 x 3,00	75	1	194,90
MCF62	MF 40 x 1,50	75	1	194,90
MCF63	MF 40 x 2,00	75	1	194,90
MCF64	MF 40 x 3,00	75	1	194,90
MCF65	MF 42 x 1,50	75	1	194,90
MCF66	MF 42 x 2,00	75	1	194,90
MCF67	MF 42 x 3,00	75	1	194,90
MCF68	MF 45 x 1,50	90	1	312,74
MCF69	MF 45 x 2,00	90	1	312,74
MCF70	MF 45 x 3,00	90	1	312,74
MCF71	MF 48 x 1,50	90	1	312,74
MCF72	MF 48 x 2,00	90	1	312,74
MCF73	MF 48 x 3,00	90	1	312,74
MCF74	MF 50 x 1,50	90	1	312,74
MCF75	MF 50 x 2,00	90	1	312,74
MCF76	MF 50 x 3,00	90	1	312,74
MCF77	MF 52 x 1,50	90	1	312,74
MCF78	MF 52 x 2,00	90	1	312,74
MCF79	MF 52 x 3,00	90	1	312,74
MCF80	MF 63 x 1,50	105	1	605,11



HSS

DIN
223



HSS

DIN
223

Rosca métrica HSS

Código	Medida	∅	PCS	€
MCP20	M 2 x 0,40	16	1	12,76
MCP21	M 2,5 x 0,45	16	1	12,76
MCP22	M 3 x 0,50	20	1	9,95
MCP23	M 3,5 x 0,60	20	1	9,95
MCP24	M 4 x 0,70	20	1	9,58
MCP25	M 5 x 0,80	20	1	9,58
MCP27	M 6 x 1,00	20	1	9,58
MCP28	M 7 x 1,00	25	1	11,50
MCP30	M 8 x 1,25	25	1	11,39
MCP31	M 9 x 1,25	25	1	11,39
MCP34	M 10 x 1,50	30	1	11,39
MCP35	M 11 x 1,50	30	1	16,20
MCP38	M 12 x 1,75	38	1	17,22
MCP42	M 14 x 2,00	38	1	18,35
MCP45	M 16 x 2,00	45	1	24,32
MCP48	M 18 x 2,50	45	1	26,31
MCP51	M 20 x 2,50	45	1	27,38
MCP53	M 22 x 2,50	55	1	38,24
MCP56	M 24 x 3,00	55	1	42,84
MCP59	M 27 x 3,00	65	1	69,96
MCP62	M 30 x 3,50	65	1	69,96

Rosca métrica fina HSS

Código	Medida	∅	PCS	€
MCP26	MF 6 x 0,75	20	1	14,11
MCP29	MF 8 x 1,00	25	1	14,52
MCP32	MF 10 x 1,00	30	1	16,82
MCP33	MF 10 x 1,25	30	1	16,82
MCP63	MF 12 x 1,00	38	1	23,12
MCP36	MF 12 x 1,25	38	1	23,12
MCP37	MF 12 x 1,50	38	1	23,12
MCP39	MF 14 x 1,00	38	1	23,12
MCP40	MF 14 x 1,25	38	1	23,12
MCP41	MF 14 x 1,50	38	1	23,12
MCP43	MF 16 x 1,00	45	1	31,45
MCP44	MF 16 x 1,50	45	1	31,45
MCP46	MF 18 x 1,00	45	1	34,17
MCP47	MF 18 x 1,50	45	1	34,17
MCP49	MF 20 x 1,50	45	1	35,67
MCP50	MF 20 x 2,00	45	1	35,67
MCP52	MF 22 x 1,50	55	1	49,47
MCP54	MF 24 x 1,50	55	1	55,73
MCP55	MF 24 x 2,00	55	1	55,73
MCP57	MF 25 x 1,50	55	1	55,73
MCP58	MF 27 x 2,00	65	1	69,96
MCP60	MF 30 x 1,50	65	1	95,30
MCP61	MF 30 x 2,00	65	1	95,30



HSS

ISO

Especiais para estojos rosca métrica HSS

Código	Medida	∅	PCS	€
MCPE30	M 2 x 0,40	25 x 9	1	19,00
MCPE31	M 3 x 0,50	25 x 9	1	11,39
MCPE32	M 4 x 0,70	25 x 9	1	11,39
MCPE33	M 5 x 0,80	25 x 9	1	11,39
MCPE34	M 6 x 1,00	25 x 9	1	11,39
MCPE35	M 7 x 1,00	25 x 9	1	11,39
MCPE36	M 8 x 1,25	25 x 9	1	11,39
MCPE37	M 10 x 1,50	25 x 9	1	11,39
MCPE38	M 12 x 1,75	25 x 9	1	12,94
MCPE39	M 10 x 1,50	38 x 14	1	18,35
MCPE40	M 12 x 1,75	38 x 14	1	18,35
MCPE41	M 14 x 2,00	38 x 14	1	18,35
MCPE42	M 16 x 2,00	38 x 14	1	18,35
MCPE43	M 18 x 2,50	38 x 14	1	25,65
MCPE44	M 20 x 2,50	38 x 14	1	25,65



HSS

ISO

Especiais para estojos métrica fina HSS

Código	Medida	∅	PCS	€
MCPE50	M 8 x 1,00	25 x 9	1	14,52
MCPE51	M 10 x 1,00	38 x 14	1	18,35
MCPE52	M 10 x 1,25	38 x 14	1	18,35
MCPE53	M 12 x 1,25	38 x 14	1	18,35
MCPE54	M 12 x 1,50	38 x 14	1	18,35
MCPE55	M 14 x 1,25	38 x 14	1	18,35
MCPE56	M 14 x 1,50	38 x 14	1	18,35
MCPE57	M 16 x 1,50	38 x 14	1	18,35
MCPE58	M 18 x 1,50	38 x 14	1	18,35



Rosca BSW/Whitworth HSS

Código	Medida	∅	PCS	€
MCP65	W 1/8 x 40	20	1	11,20
MCP66	W 5/32 x 32	20	1	11,20
MCP67	W 3/16 x 24	20	1	11,20
MCP68	W 7/32 x 24	20	1	12,76
MCP69	W 1/4 x 20	20	1	12,76
MCP70	W 5/16 x 18	25	1	12,76
MCP71	W 3/8 x 16	30	1	14,40
MCP72	W 7/16 x 14	30	1	18,95
MCP73	W 1/2 x 12	38	1	21,79
MCP74	W 9/16 x 12	38	1	21,79
MCP75	W 5/8 x 11	45	1	26,31
MCP76	W 3/4 x 10	45	1	32,08
MCP77	W 7/8 x 9	55	1	47,99
MCP78	W 1" x 8	55	1	49,94
MCP79	W 1"1/4 x 7	76	1	158,39
MCP80	W 1"1/2 x 6	76	1	158,39

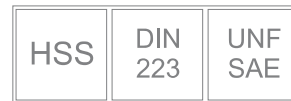

Rosca UNF/SAE HSS

Código	Medida	∅	PCS	€
MCP82	UNF 1/4 x 28	20	1	15,55
MCP83	UNF 5/16 x 24	25	1	15,55
MCP84	UNF 3/8 x 24	30	1	17,74
MCP85	UNF 7/16 x 20	30	1	17,79
MCP86	UNF 1/2 x 20	38	1	24,07
MCP87	UNF 9/16 x 18	38	1	24,07
MCP88	UNF 5/8 x 18	45	1	30,20
MCP89	UNF 3/4 x 16	45	1	35,83
MCP90	UNF 7/8 x 14	55	1	49,42
MCP91	UNF 1" x 12	55	1	53,34

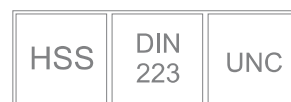

Rosca UNC HSS

Código	Medida	∅	PCS	€
MCU01	UNC 1/4 x 20	20	1	16,40
MCU02	UNC 5/16 x 18	25	1	11,58
MCU03	UNC 3/8 x 16	30	1	13,77
MCU04	UNC 7/16 x 14	30	1	13,82
MCU05	UNC 1/2 x 13	38	1	21,79
MCU06	UNC 9/16 x 12	38	1	21,79
MCU07	UNC 5/8 x 11	45	1	21,79
MCU08	UNC 3/4 x 10	45	1	29,43
MCU09	UNC 7/8 x 9	55	1	42,74



Rosca BSP - GAS

Código	Medida	∅	PCS	€
MCG20	G 1/8 x 28	30	1	12,55
MCG21	G 1/4 x 19	38	1	17,16
MCG22	G 3/8 x 19	45	1	22,24
MCG23	G 1/2 x 14	45	1	22,24
MCG24	G 5/8 x 14	55	1	35,83
MCG25	G 3/4 x 14	55	1	37,26
MCG26	G 7/8 x 14	65	1	48,50
MCG27	G 1" x 11	65	1	49,36
MCG29	G 1"1/4 x 11	75	1	63,76
MCG31	G 1"1/2 x 11	90	1	103,11
MCG33	G 2" x 11	105	1	126,43

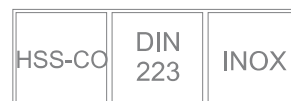

Rosca métrica HSS-CO para inox-vapo

Código	Medida	∅	PCS	€
MCPI02	M 3 x 0,50	20,6	1	13,82
MCPI03	M 4 x 0,70	20,6	1	13,36
MCPI04	M 5 x 0,80	20,6	1	12,27
MCPI14	M 6 x 1,00	20,6	1	12,27
MCPI07	M 8 x 1,25	25,4	1	16,47
MCPI08	M 10 x 1,50	30	1	20,28
MCPI09	M 12 x 1,75	38,1	1	24,14
MCPI10	M 14 x 2,00	38,1	1	26,27
MCPI11	M 16 x 2,00	45	1	37,38
MCPI12	M 18 x 2,50	45	1	37,55
MCPI13	M 20 x 2,50	45	1	39,69



Desandador de machos em ZAMAC

Código	Medida	Métrica	BSW	BSP	€
MMZD01	Nº 0	1 ÷ 8	1/16 ÷ 1/4		2,56
MMZD07	Nº 1	1 ÷ 10	1/16 ÷ 3/8	1/8	3,15
MMZD03	Nº 2	4 ÷ 12	5/32 ÷ 1/2	1/8	7,22
MMZD04	Nº 3	5 ÷ 20	7/32 ÷ 3/4	1/8 ÷ 1/2	14,62
MMZD05	Nº 4	11 ÷ 27	7/16 ÷ 1"	1/4 ÷ 3/4	18,57
MMZD06	Nº 5	13 ÷ 32	1/2 ÷ 1"1/4	1/4 ÷ 1"	28,11



Desandador de caçonetes em ZAMAC

Código	Medida	Métrica	BSW / BSP	€
MCZD01	16 x 5	M 1 ÷ 2,6	W 1/16 ÷ 3/32	2,19
MCZD02	20 x 5	M 3 ÷ 4	W 1/8 ÷ 5/32	2,50
MCZD03	20 x 7	M 4,5 ÷ 6	W 3/16 ÷ 1/4	2,50
MCZD04	25 x 9	M 7 ÷ 9	W 5/16	3,12
MCZD05	30 x 11	M 10 ÷ 11	W 3/8 ÷ 7/16	4,40
MCZD07	38 x 14	M 12 ÷ 14	W 1/2 ÷ 9/16	6,51
MCZD09	45 x 18	M 16 ÷ 20	W 5/8 ÷ 13/16	9,33
MCZD11	55 x 22	M 22 ÷ 24	W 7/8 ÷ 1"	13,49
MCZD13	65 x 25	M 27 ÷ 36	W 1"1/8 ÷ 1"3/8	19,47



Desandador de machos em aço

Código	Medida	Métrica	BSW	BSP	€
MMCD01	Nº 0	1 ÷ 8	1/16 ÷ 1/4		11,78
MMCD02	Nº 1	1 ÷ 10	1/16 ÷ 3/8	1/8	12,62
MMCD03	Nº 2	4 ÷ 12	5/32 ÷ 1/2	1/8	18,51
MMCD04	Nº 3	5 ÷ 20	7/32 ÷ 3/4	1/8 ÷ 1/2	30,29
MMCD05	Nº 4	11 ÷ 27	7/16 ÷ 1"	1/4 ÷ 3/4	48,80
MMCD06	Nº 5	13 ÷ 32	1/2 ÷ 1"1/4	1/4 ÷ 1"	114,74
MMCD07	Nº 6	18 ÷ 42	3/4 ÷ 1"1/2	1/2 ÷ 1"1/4	128,36
MMCD08	Nº 7	25 ÷ 52	1" ÷ 2"1/8	3/4 ÷ 2" 1/4	149,00



Desandador de caçonetes em aço

Código	Medida	Métrica	BSW / BSP	€
MCD20	20 x 7	M 4,5 ÷ 6	W 3/16 ÷ 1/4	14,72
MCD25	25 x 9	M 7 ÷ 9	W 5/16	16,62
MCD30	30 x 11	M 10 ÷ 11	W 3/8 ÷ 7/16	16,62
MCD38	38 x 14	M 12 ÷ 14	W 1/2 ÷ 9/16	19,00
MCD45	45 x 18	M 16 ÷ 20	W 5/8 ÷ 13/16	24,94
MCD55	55 x 22	M 22 ÷ 24	W 7/8 ÷ 1"	30,89
MCD65	65 x 25	M 27 ÷ 36	W 1"1/8 ÷ 1"3/8	42,50
MCD75	75 x 30	M 39 ÷ 42	W 1"1/2 ÷ 1"5/8	60,81

Desandador de machos com roquete ISO



Código	Medida	Capacidade	PCS	€
MMD01	M 3 - M 10	85 mm	1	14,20
MMD02	M 5 - M 12	100 mm	1	17,00

Desandador de machos com roquete longo



Código	Medida	Comprimento	PCS	€
MML01	M 3 - M 10	250 mm	1	22,78
MML02	M 5 - M 12	300 mm	1	30,68



Extractor de parafusos

Código	(mm)	Medida (")	PCS	€
MMEX1	3 - 6	1/8 - 1/4	1	1,32
MMEX2	6 - 8	1/4 - 5/16	1	1,32
MMEX3	8 - 11	5/16 - 7/16	1	1,61
MMEX4	11 - 14	7/16 - 9/16	1	1,89
MMEX5	14 - 18	9/16 - 3/4	1	2,46
MMEX6	18 - 24	3/4 - 1"	1	3,43

Jogo de extractores de parafusos em caixa plástica



Código	Medida	PCS	€
MMEX7	3 a 18	1	9,10
MMEX8	3 a 24	1	13,16



Estojo de 3 a 12 HSS-G

Composição: 30 peças Código: MJOGO01

Machos (3 de cada medida)
M3, M4, M5, M6, M8, M10, M12
Caçonetes (1 de cada medida)
M3, M4, M5, M6, M8, M10, M12
1 Desandador de machos Nº1
1 Desandador de caçonetes 25,4

118,56 €



Estojo de 3 a 20 HSS-G

Composição: 54 peças Código: MJOGO02

Machos (3 de cada medida)
M3, M4, M5, M6, M8, M10, M12, M14, M16, M18, M20
Caçonetes (1 de cada medida)
M3, M4, M5, M6, M8, M10, M12, M14, M16, M18, M20
Desandador de caçonetes (1 de cada medida)
20x5, 20x7, 25, 30, 38, 45
Desandador de machos (1 de cada medida) Nº1, Nº3
Roquetes (1 de cada medida) Nº1, Nº2

427,29 €



Estojo de 3 a 24 HSS-G

Composição: 61 peças Código: MJOGO03

Machos (3 de cada medida) M3, M4, M5, M6, M8, M10, M12, M14, M16, M18, M20, M22, M24
Caçonetes (1 de cada medida) M3, M4, M5, M6, M8, M10, M12, M14, M16, M18, M20, M22, M24
Desandador de caçonetes (1 de cada medida)
20x5, 20x7, 25, 30, 38, 45, 55
Desandador de machos (1 de cada medida) Nº1, Nº4

831,92 €

Estojo de 3 a 24 HSS-CO

Composição: 61 peças Código: MJOGO04

Machos (3 de cada medida) M3, M4, M5, M6, M8, M10, M12, M14, M16, M18, M20, M22, M24
Caçonetes (1 de cada medida) M3, M4, M5, M6, M8, M10, M12, M14, M16, M18, M20, M22, M24
Desandador de caçonetes (1 de cada medida)
20x5, 20x7, 25, 30, 38, 45, 55
Desandador de machos (1 de cada medida) Nº1, Nº4

1.085,76 €



Estojo BSW 1/8 a 1/2"

Composição: 36 peças Código: MJOGO05

Machos (3 de cada medida) 1/8, 3/16, 1/4, 5/16, 3/8, 7/16, 1/2
 Caçonetes (1 de cada medida) 1/8, 3/16, 1/4, 5/16, 3/8, 7/16, 1/2
 Desandador de machos (1 de cada medida) N°1, N°2 Roquetes N°1
 Desandador de caçonetes (1 de cada medida) 20x5, 20x7, 25, 30, 38

416,83 €

Estojo BSW 1/4 a 3/4"

Composição: 39 peças Código: MJOGO06

Machos (3 de cada medida) 1/4, 5/16, 3/8, 7/16, 1/2, 9/16, 5/8, 3/4
 Caçonetes (1 de cada medida) 1/4, 5/16, 3/8, 7/16, 1/2, 9/16, 5/8, 3/4
 Desandador de machos (1 de cada medida) N°1, N°3
 Desandador de caçonetes (1 de cada medida) 20x7, 25, 30, 38, 45

544,13 €

Estojo BSW 1/4 a 1"

Composição: 43 peças Código: MJOGO07

Machos (3 de cada medida) 1/4, 5/16, 3/8, 7/16, 1/2, 5/8, 3/4, 7/8, 1"
 Caçonetes (1 de cada medida) 1/4, 5/16, 3/8, 7/16, 1/2, 5/8, 3/4, 7/8, 1"
 Desandador de machos (1 de cada medida) N°1, N°4
 Desandador de caçonetes (1 de cada medida) 20x7, 25, 30, 38, 45, 55

811,20 €

Estojos de machos e caçonetes auto especiais para garagem em C. V.

Standard



Estojo Standard M2 a M18

Rosca métrica e rosca métrica fina

Composição: 110 peças Código: MEMEM123

Machos (2 de cada medida)		Caçonetes (1 de cada medida)	
M2x0,40	M11x0,75	M2x0,40	M11x0,75
M3x0,50	M11x1,00	M3x0,50	M11x1,00
M4x0,70	M11x1,25	M4x0,70	M11x1,25
M5x0,80	M11x1,50	M5x0,80	M11x1,50
M6x0,75	M12x0,75	M6x0,75	M12x0,75
M6x1,00	M12x1,00	M6x1,00	M12x1,00
M7x0,75	M12x1,25	M7x0,75	M12x1,25
M7x1,00	M12x1,50	M7x1,00	M12x1,50
M8x0,75	M12x1,75	M8x0,75	M12x1,75
M8x1,00	M14x1,00	M8x1,00	M14x1,00
M8x1,25	M14x1,25	M8x1,25	M14x1,25
M9x0,75	M14x1,50	M9x0,75	M14x1,50
M9x1,00	M14x2,00	M9x1,00	M14x2,00
M9x1,25	M16x1,00	M9x1,25	M16x1,00
M10x0,75	M16x1,50	M10x0,75	M16x1,50
M10x1,00	M16x2,00	M10x1,00	M16x2,00
M10x1,25	M18x1,50	M10x1,25	M18x1,50
M10x1,50		M10x1,50	

Desandador de machos N°1 e N°3
 Desandador de caçonetes 25,4 e 38,1
 Roquete N°1

310,96 €

Professional



Estojo Professional M2 a M18

Rosca métrica e rosca métrica fina

(mesma composição do Standard + paquímetro)

Composição: 111 peças Código: MEMEM124

+ Paquímetro 0 a 150mm 0,01 digital 330,72 €



HSS-CO DIN371

Comp.: 10 machos
Código: MJM01

Navalhas direitas
M3, M4, M5, M6, M8

Navalhas helicoidais
M3, M4, M5, M6, M8

80,97 €



HSS-Vapo inox

Comp.: 10 machos
Código: MJM02

Navalhas direitas
M3, M4, M5, M6, M8

Navalhas helicoidais
M3, M4, M5, M6, M8

134,25 €



Trabalhos especiais HSS-CO

Comp.:35 machos Código: MJM03

VAPO INOX	Nav. Dir. M3, M4, M5, M6, M8
	Nav. Hel. M3, M4, M5, M6, M8
Aluminio	Nav. Dir. M3, M4, M5, M6, M8
Laminação	Nav. Dir. M3, M4, M5, M6, M8
Macho Broca	Nav. dir. M3, M4, M5, M6, M8
TIN	Nav. Dir. M3, M4, M5, M6, M8
TIALN	Nav. Dir. M3, M4, M5, M6, M8

523,56 €



KIT PROFISSIONAL composto por:

- Jogo machos maquina-brocas HSS M3-M12 (15 peças)
- Jogo escareadores HSS 6,3 - 20,5mm (6 peças)
- Jogo de caçonetes HSS M3-M12 e desandador
- Oferta de um paquímetro

Código: MM900 151,95 €



Jogo de machos de máquina-brocas HSS M3-M12

Composição: 15 peças Código: MM901

Jogo de machos maquina - brocas
Machos DIN 352
M3 / M4 / M5 / M6 / M8 / M10 / M12
Brocas
Ø 2,5 / 3,3 / 4,2 / 5,0 / 6,8 / 8,5 / 10,2 mm
+desandador de machos

43,43 €



Jogo de escareadores HSS

Composição: 6 peças Código: MM902

Escareador DIN335C
Ø 6,3/8,3/10,4/12,4/16,5/20,5

45,24 €



Jogo de caçonetes HSS

Composição: 8 peças Código: MM903

Caçonetes DIN223
Ø 25 mm: M3 / M4 / M5 / M6 / M8 / M10 / M12
+desandador de caçonetes 25 x 9

30,70 €



FRENTE

VERSO



KIT UNIVERSAL composto por:

- Jogo machos maquina-brocas M3-M12 HSS
- Jogo de brocas escalonadas 4-12/4-20/4-30 HSS
- Jogo de escareadores 6,3 - 20,5mm HSS
- Óleo spray 50ml
- Livro técnico
- Paquímetro digital
- Conta - fios

Código: MM910 237,42 €







MINI KIT PROFISSIONAL composto por:

- Jogo machos maquina-brocas HSS M3-M10
- Jogo de caçonetes HSS M3-M12
- Oferta óleo spray 50ml

Código: MM904 89,70 €

Até fim de existências



Código						€
KC600	M 2 x 0,40	2,1mm	Nº 2	Nº 2	20 PCS	29,03
KC601	M 2,5 x 0,45	2,6mm	Nº 3	Nº 3	20 PCS	29,03
KC602	M 3 x 0,50	3,2mm	Nº 4	Nº 4	20 PCS	29,03
KC603	M 3,5 x 0,60	3,7mm	Nº 5	Nº 5	20 PCS	29,03
KC604	M 4 x 0,70	4,2mm	Nº 6	Nº 6	20 PCS	29,03
KC605	M 5 x 0,80	5,2mm	Nº 8	Nº 8	20 PCS	30,16
KC606	M 6 x 1,00	6,3mm	Nº 9	Nº 9	20 PCS	32,55
KC607	M 7 x 1,00	7,3mm	Nº 10	Nº 10	20 PCS	41,44
KC608	M 8 x 1,25	8,3mm	Nº 11	Nº 11	20 PCS	41,44
KC609	M 8 x 1,00	8,3mm	Nº 11	Nº 11	20 PCS	41,44
KC610	M 9 x 1,25	9,3mm	Nº 12	Nº 12	15 PCS	45,95
KC611	M 10 x 1,50	10,4mm	Nº 13	Nº 13	15 PCS	44,26
KC612	M 10 x 1,25	10,3mm	Nº 13	Nº 13	15 PCS	43,94
KC613	M 10 x 1,00	10,3mm	Nº 13	Nº 13	15 PCS	44,26
KC614	M 11 x 1,50	11,4mm	Nº 14	Nº 14	10 PCS	49,61
KC615	M 12 x 1,75	12,4mm	Nº 15	Nº 15	10 PCS	49,61
KC616	M 12 x 1,50	12,4mm	Nº 15	Nº 15	10 PCS	49,61
KC617	M 12 x 1,25	12,3mm	Nº 15	Nº 15	10 PCS	49,61
KC618	M 12 x 1,00	12,3mm	Nº 15	Nº 15	10 PCS	49,61
KC619	M 14 x 2,00		Nº 16		10 PCS	59,50
KC620	M 14 x 1,50		Nº 16		10 PCS	59,50
KC621	M 14 x 1,25		Nº 17		10 PCS	59,50
KC622	M 14 x 1,00		Nº 17		10 PCS	59,50
KC623	M 16 x 2,00		Nº 18		10 PCS	72,03
KC624	M 16 x 1,50		Nº 18		10 PCS	72,03
KC625	M 18 x 2,50		Nº 20		5 PCS	91,18
KC626	M 18 x 2,00		Nº 20		5 PCS	91,18
KC627	M 18 x 1,50		Nº 20		5 PCS	91,18
KC628	M 20 x 2,50		Nº 21		5 PCS	98,74
KC629	M 20 x 2,00		Nº 21		5 PCS	98,74
KC630	M 20 x 1,50		Nº 21		5 PCS	98,74
KC631	M 22 x 2,50		Nº 22		5 PCS	113,72
KC632	M 22 x 2,00		Nº 22		5 PCS	113,72
KC633	M 22 x 1,50		Nº 22		5 PCS	113,72
KC634	M 24 x 3,00		Nº 23		5 PCS	131,11
KC635	M 24 x 2,00		Nº 23		5 PCS	131,11
KC636	M 24 x 1,50		Nº 23		5 PCS	131,11

Outras medidas sob consulta



Jogos para reparar roscas K-Coil UNF

Código							€
KC669	UNF	1/4 x 28	6,7mm	Nº 9	Nº 9	20 PCS	45,86
KC670	UNF	5/16 x 24	8,3mm	Nº 11	Nº 11	20 PCS	56,19
KC671	UNF	3/8 x 24	9,8mm	Nº 13	Nº 13	15 PCS	59,96
KC672	UNF	7/16 x 20	11,5mm	Nº 14	Nº 14	10 PCS	67,29
KC673	UNF	1/2 x 20	13mm	Nº 15	Nº 15	10 PCS	73,86
KC674	UNF	9/16 x 18		Nº 16		10 PCS	99,20
KC675	UNF	5/8 x 18		Nº 18		10 PCS	99,20
KC676	UNF	3/4 x 16		Nº 21		5 PCS	126,04
KC677	UNF	7/8 x 14		Nº 22		5 PCS	153,64
KC678	UNF	1" x 12		Nº 23		4 PCS	146,18

OUTRAS MEDIDAS SOB CONSULTA

Jogos para reparar roscas K-Coil BSP

Código					€
KC705	BSP	1/8 x 28	1	10 PCS	93,23
KC706	BSP	1/4 x 19	1	10 PCS	101,43
KC707	BSP	3/8 x 19	1	10 PCS	108,89
KC708	BSP	1/2 x 14	1	10 PCS	132,01
KC709	BSP	5/8 x 14	1	10 PCS	310,25
KC710	BSP	3/4 x 14	1	10 PCS	310,25
KC711	BSP	7/8 x 14	1	10 PCS	426,60
KC712	BSP	1" x 11	1	10 PCS	426,60

OUTRAS MEDIDAS SOB CONSULTA



Código		PCS							€
KC751	M5 a M12	130	M 5 x 0,80	5,2mm	Nº 8	Nº 8	25 PCS	195,90	
			M 6 x 1,00	6,3mm	Nº 9	Nº 9	25 PCS		
			M 8 x 1,25	8,3mm	Nº 11	Nº 11	25 PCS		
			M 10 x 1,50	10,4mm	Nº 13	Nº 13	25 PCS		
			M 12 x 1,75	12,4mm	Nº 15	Nº 15	10 PCS		
KC750	M6 a M10	87	M 6 x 1,00	6,3mm	Nº 9	Nº 9	25 PCS	137,86	
			M 8 x 1,25	8,3mm	Nº 11	Nº 11	25 PCS		
			M 10 x 1,50	10,4mm	Nº 13	Nº 13	25 PCS		
KC752	M6 a M14x1,25	113	M 6 x 1,00	6,3mm	Nº 9	Nº 9	25 PCS	252,01	
			M 8 x 1,25	8,3mm	Nº 11	Nº 11	25 PCS		
			M 10 x 1,50	10,4mm	Nº 13	Nº 13	25 PCS		
			M 12 x 1,75	12,4mm	Nº 15	Nº 15	10 PCS		
			M 14 x 1,25		Nº 17		10 PCS		
KC753	M6 a M14x1,25	115	M 6 x 1,00	6,3mm	Nº 9	Nº 9	25 PCS	259,90	
			M 8 x 1,25	8,3mm	Nº 11	Nº 11	25 PCS		
			M 10 x 1,50	10,4mm	Nº 13	Nº 13	25 PCS		
			M 12 x 1,75	12,4mm	Nº 15	Nº 15	10 PCS		
			Especial para velas →	M 14 x 1,25		Nº 17			10 PCS
KC754	UNC 1/4 a 1/2	115	1/4 x 20	6,7mm	Nº 9	Nº 9	25 PCS	283,52	
			5/16 x 18	8,3mm	Nº 10	Nº 11	25 PCS		
			3/8 x 16	9,9mm	Nº 12	Nº 12	25 PCS		
			7/16 x 14	11,6mm	Nº 14	Nº 14	10 PCS		
			1/2 x 13	13mm	Nº 15	Nº 15	10 PCS		
KC755	UNF 1/4 a 1/2	115	1/4 x 28	6,7mm	Nº 9	Nº 9	25 PCS	283,52	
			5/16 x 24	8,3mm	Nº 11	Nº 11	25 PCS		
			3/8 x 24	9,8mm	Nº 13	Nº 13	25 PCS		
			7/16 x 20	11,5mm	Nº 14	Nº 14	10 PCS		
			1/2 x 20	13mm	Nº 15	Nº 15	10 PCS		
KC756	BSW 1/4 a 1/2	115	1/4 x 20	6,7mm	Nº 9	Nº 9	25 PCS	283,52	
			5/16 x 18	8,3mm	Nº 10	Nº 11	25 PCS		
			3/8 x 16	9,9mm	Nº 12	Nº 12	25 PCS		
			7/16 x 14	11,5mm	Nº 14	Nº 14	10 PCS		
			1/2 x 12	13mm	Nº 15	Nº 15	10 PCS		
KC757	BSF 1/4 a 1/2	115	1/4 x 26	6,6mm	Nº 9	Nº 9	25 PCS	283,52	
			5/16 x 22	8,3mm	Nº 11	Nº 11	25 PCS		
			3/8 x 20	9,9mm	Nº 12	Nº 12	25 PCS		
			7/16 x 18	11,5mm	Nº 14	Nº 14	10 PCS		
			1/2 x 16	13mm	Nº 15	Nº 15	10 PCS		



Rosca métrica HSS

Código	Medida	PCS	€
KC400	M 2 x 0,40	1	11,73
KC401	M 2,5 x 0,45	1	11,73
KC514	M 3 x 0,50	1	10,13
KC403	M 3,5 x 0,60	1	9,11
KC404	M 4 x 0,70	1	9,11
KC405	M 5 x 0,80	1	9,11
KC406	M 6 x 1,00	1	9,11
KC407	M 7 x 1,00	1	11,32
KC408	M 8 x 1,00	1	11,32
KC409	M 8 x 1,25	1	11,32
KC410	M 9 x 1,25	1	13,84
KC411	M 10 x 1,00	1	13,84
KC412	M 10 x 1,25	1	13,84
KC413	M 10 x 1,50	1	13,84
KC414	M 11 x 1,50	1	15,73
KC415	M 12 x 1,00	1	18,86
KC416	M 12 x 1,25	1	19,18
KC417	M 12 x 1,50	1	19,18
KC418	M 12 x 1,75	1	15,73
KC419	M 14 x 1,00	1	21,86
KC420	M 14 x 1,25	1	21,86
KC421	M 14 x 1,50	1	21,86
KC422	M 14 x 2,00	1	21,86
KC423	M 16 x 1,50	1	26,26
KC424	M 16 x 2,00	1	26,26
KC425	M 18 x 1,50	1	33,02
KC426	M 18 x 2,00	1	33,02
KC427	M 18 x 2,50	1	33,02
KC428	M 20 x 1,50	1	36,32
KC429	M 20 x 2,00	1	36,32
KC430	M 20 x 2,50	1	36,32
KC431	M 22 x 1,50	1	41,82
KC432	M 22 x 2,00	1	41,82
KC433	M 22 x 2,50	1	41,82
KC434	M 24 x 1,50	1	52,84
KC435	M 24 x 2,00	1	52,84
KC436	M 24 x 3,00	1	52,84

Outras medidas sob consulta



Macho K-Coil Combi (especial para velas)
Rosca Métrica / Rosca métrica fina

Código	Medida	PCS	€
KC550	M 6 x 1,00	1	17,91
KC551	M 8 x 1,25	1	17,91
KC552	M 10 x 1,00	1	22,64
KC553	M 10 x 1,50	1	22,64
KC554	M 12 x 1,25	1	32,56
KC555	M 14 x 1,25	1	37,77
KC556	M 18 x 1,50	1	54,05



Rosca UNC - UNF - BSW - BSF - BSP em HSS

Código	Medida	PCS	€
KC454	UNC 1/2 x 13	1	17,76
KC455	UNC 1/4 x 20	1	10,30
KC456	UNC 3/8 x 16	1	11,73
KC457	UNC 5/16 x 18	1	11,19
KC458	UNC 7/16 x 14	1	15,63
KC459	UNC 9/16 x 12	1	29,48
KC460	UNC 5/8 x 11	1	36,36
KC461	UNC 3/4 x 10	1	44,23
KC462	UNC 7/8 x 9	1	51,51
KC463	UNC 1" x 8	1	51,51
KC469	UNF 1/2 x 20	1	18,48
KC470	UNF 1/4 x 28	1	10,30
KC471	UNF 3/8 x 24	1	11,73
KC472	UNF 5/16 x 24	1	11,19
KC473	UNF 7/16 x 20	1	15,63
KC474	UNF 9/16 x 18	1	29,48
KC475	UNF 5/8 x 18	1	36,41
KC476	UNF 3/4 x 16	1	44,23
KC477	UNF 7/8 x 14	1	51,51
KC478	UNF 1" x 12	1	51,51
KC483	BSW 1/8 x 40	1	10,30
KC484	BSW 3/16 x 24	1	10,30
KC485	BSW 1/2 x 12	1	17,76
KC486	BSW 1/4 x 20	1	10,30
KC487	BSW 3/8 x 16	1	11,73
KC488	BSW 5/16 x 18	1	11,73
KC489	BSW 7/16 x 14	1	15,63
KC490	BSW 9/16 x 12	1	29,48
KC491	BSW 5/8 x 11	1	36,41
KC492	BSW 3/4 x 10	1	44,23
KC493	BSW 7/8 x 9	1	51,51
KC494	BSW 1" x 8	1	51,51
KC495	BSF 3/16 x 32	1	10,80
KC496	BSF 1/2 x 16	1	17,76
KC497	BSF 1/4 x 26	1	10,30
KC498	BSF 3/8 x 20	1	11,73
KC499	BSF 5/16 x 22	1	11,73
KC500	BSF 7/16 x 18	1	15,63
KC501	BSF 9/16 x 16	1	30,91
KC502	BSF 5/8 x 14	1	38,16
KC503	BSF 3/4 x 12	1	46,35
KC504	BSF 7/8 x 11	1	53,98
KC505	BSF 1" x 10	1	53,98

Jogo de 2 machos

KC506	BSP 1/8 x 28	2	50,40
KC507	BSP 1/4 x 19	2	66,15
KC508	BSP 3/8 x 19	2	81,90
KC509	BSP 1/2 x 14	2	96,60
KC510	BSP 5/8 x 14	2	132,30
KC511	BSP 3/4 x 14	2	196,35
KC512	BSP 7/8 x 14	2	247,80
KC513	BSP 1" x 11	2	305,55

Prazo de entrega sujeito a confirmação



Utensílio manual para inserir o inserto K-Coil

Código	Nº	Rosca	PCS	€
KC800	2	M 2	1	11,30
KC801	3	M 2,5	1	11,30
KC802	4	M 3	1	10,79
KC803	5	M 3,5	1	10,79
KC804	6	M 4	1	10,79
KC805	8	M 5	1	10,79
KC806	9	M 6	1	10,79
KC807	10	M 7	1	12,32
KC808	11	M 8	1	12,32
KC809	12	M 9	1	13,26
KC810	13	M 10	1	13,26
KC811	14	M 11	1	15,53
KC812	15	M 12	1	15,53
KC813	16	M 14	1	18,09
KC814	17	M 14	1	18,09
KC815	18	M 16	1	20,46
KC816	20	M 18	1	20,46
KC817	21	M 20	1	20,46
KC818	22	M 22	1	25,76
KC819	23	M 24	1	25,76



Utensílio para rotura do perno

Código	Nº	Rosca	PCS	€
KC300	2	M 2	1	4,27
KC301	3	M 2,5	1	4,27
KC302	4	M 3	1	4,27
KC303	5	M 3,5	1	4,27
KC304	6	M 4	1	4,27
KC305	8	M 5	1	4,27
KC306	9	M 6	1	4,27
KC307	10	M 7	1	4,80
KC308	11	M 8	1	4,80
KC309	12	M 9	1	4,80
KC310	13	M 10	1	5,76
KC311	14	M 11	1	5,76



Extractor K-Coil

Código	Nº	Rosca	PCS	€
KC880	2	M 3 - 10	1	25,26
KC881	3	M 11 - 24	1	30,73





Medida	Código	PCS	€	Código	PCS	€	Código	PCS	€	Código	PCS	€	Código	PCS	€
M 2 x 0,40	KC001	100	0,64	KC043	100	0,84	KC161	100	0,98	KC221	25	1,17	KC261	25	1,28
M 2,5 x 0,45	KC002	100	0,20	KC044	100	0,21	KC162	100	0,22	KC222	25	1,17	KC262	25	1,28
M 3 x 0,50	KC003	100	0,20	KC045	100	0,21	KC163	100	0,22	KC223	25	1,17	KC263	25	1,28
M 3,5 x 0,60	KC004	100	0,22	KC046	100	0,24	KC164	100	0,25	KC224	25	1,17	KC264	25	1,28
M 4 x 0,70	KC005	100	0,20	KC047	100	0,21	KC165	100	0,22	KC225	25	0,45	KC265	25	0,49
M 5 x 0,80	KC006	100	0,22	KC048	100	0,18	KC166	100	0,25	KC226	25	0,45	KC266	25	0,48
M 6 x 1,00	KC007	100	0,24	KC049	100	0,20	KC167	100	0,28	KC227	25	0,55	KC267	25	0,59
M 7 x 1,00	KC008	100	0,26	KC050	100	0,32	KC168	100	0,35	KC228	25	0,71	KC268	25	0,72
M 8 x 1,00	KC009	100	0,28	KC051	100	0,28	KC169	100	0,37	KC229	25	0,60	KC269	25	0,80
M 8 x 1,25	KC010	100	0,25	KC052	100	0,25	KC170	100	0,35	KC230	25	0,69	KC270	25	0,91
M 9 x 1,25	KC011	100	0,35	KC053	100	0,47	KC171	100	0,47	KC231	10	0,95	KC271	10	1,16
M 10 x 1,00	KC012	50	0,32	KC054	50	0,35	KC172	50	0,40	KC232	10	0,78	KC272	10	1,04
M 10 x 1,25	KC013	50	0,32	KC055	50	0,35	KC173	50	0,40	KC233	10	0,90	KC273	10	1,20
M 10 x 1,50	KC014	50	0,35	KC056	50	0,35	KC174	50	0,40	KC234	10	1,11	KC274	10	1,39
M 11 x 1,50	KC015	50	0,53	KC057	50	0,59	KC175	50	0,63	KC235	10	1,46	KC275	10	1,39
M 12 x 1,00	KC016	50	0,47	KC058	50	0,55	KC176	50	0,61	KC236	10	1,12	KC276	10	1,29
M 12 x 1,25	KC017	50	0,47	KC059	50	0,55	KC177	50	0,61	KC237	10	1,17	KC277	10	1,29
M 12 x 1,50	KC018	50	0,47	KC061	50	0,55	KC179	50	0,61	KC238	10	1,19	KC278	10	1,49
M 12 x 1,75	KC019	50	0,47	KC062	50	0,55	KC180	50	0,61	KC239	10	1,52	KC279	10	1,81
M 14 x 1,00	KC020	25	0,85	KC063	25	0,88	KC181	25	1,03	KC240	10	1,43	KC280	10	1,67
M 14 x 1,25	KC021	25	0,71	KC064	25	0,82	KC185	25	0,84	KC241	10	1,38	KC281	10	2,10
M 14 x 1,50	KC022	25	0,71	KC068	25	0,82	KC186	25	0,84	KC242	10	1,65	KC282	10	2,12
M 14 x 2,00	KC023	25	0,71	KC069	25	0,82	KC187	25	0,84	KC243	10	2,23	KC283	10	2,74
M 16 x 1,50	KC024	25	0,97	KC070	25	1,01	KC188	25	1,24	KC244	10	2,34	KC284	10	2,64
M 16 x 2,00	KC025	25	0,97	KC071	25	1,01	KC189	25	1,24	KC245	10	2,49	KC285	10	3,94
M 18 x 1,50	KC026	25	1,41	KC072	25	1,63	KC190	25	2,22	KC246	10	1,68	KC286	10	1,83
M 18 x 2,00	KC027	25	1,41	KC074	25	1,63	KC192	25	2,22	KC247	10	2,37	KC287	10	2,86
M 18 x 2,50	KC028	25	1,41	KC075	25	1,63	KC193	25	2,22	KC248	10	2,37	KC288	10	2,85
M 20 x 1,50	KC029	25	1,63	KC076	25	2,07	KC194	25	2,66	KC249	10	1,85	KC289	10	2,61
M 20 x 2,00	KC030	25	1,63	KC077	25	2,07	KC195	25	2,66	KC250	10	2,93	KC290	10	3,53
M 20 x 2,50	KC031	25	1,76	KC078	25	2,07	KC196	25	2,66	KC251	10	3,08	KC291	10	3,64
M 22 x 1,50	KC032	25	1,76	KC079	25	2,22	KC197	25	2,80	KC252	10	2,64	KC292	10	3,18
M 22 x 2,00	KC033	25	1,76	KC080	25	2,46	KC198	25	2,80	KC253	10	4,01	KC293	10	4,90
M 22 x 2,50	KC034	25	1,76	KC081	25	2,22	KC199	25	3,06	KC254	10	3,84	KC294	10	5,52
M 24 x 1,50	KC035	25	2,22	KC082	25	2,36	KC200	25	2,95	KC255	10	4,08	KC295	10	4,57
M 24 x 2,00	KC036	25	2,22	KC083	25	2,36	KC201	25	2,95	KC256	10	4,59	KC296	10	5,29
M 24 x 3,00	KC037	25	2,22	KC084	25	3,59	KC202	25	4,83	KC257	10	5,76	KC297	10	8,52

Outras medidas sob consulta

Instruções de uso

1. Furar a rosca danificada com uma broca.
2. Roscar com um macho K-coil.
3. Biselar o diâmetro exterior a 90° e retirar a rebarba.
4. Colocar o inserto com a ajuda do utensílio manual.
5. No caso de furos passantes use o utensílio para rotação do perno.

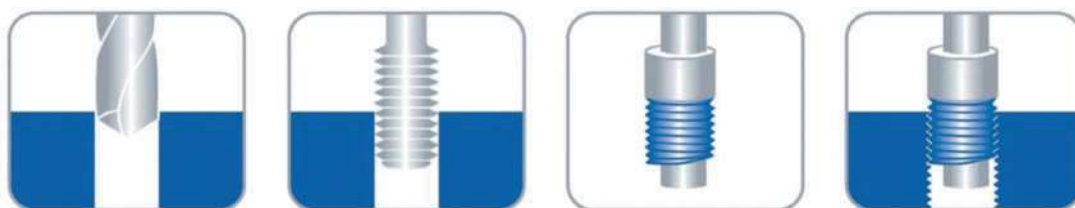



Código		Medida	PCS	€
KC102	UNC	1/2 x 13	10	1,24
KC103	UNC	1/4 x 20	10	0,43
KC104	UNC	3/8 x 16	10	0,71
KC105	UNC	5/16 x 18	10	0,56
KC106	UNC	7/16 x 14	10	1,09
KC107	UNC	9/16 x 12	10	3,15
KC108	UNC	5/8 x 11	10	2,86
KC109	UNC	3/4 x 10	10	3,38
KC110	UNC	7/8 x 9	10	4,96
KC111	UNC	1" x 8	10	4,96
x				
KC117	UNF	1/2 x 20	10	0,82
KC118	UNF	1/4 x 28	10	0,43
KC119	UNF	3/8 x 24	10	0,61
KC120	UNF	5/16 x 24	10	0,50
KC121	UNF	7/16 x 20	10	0,82
KC122	UNF	9/16 x 18	10	1,71
KC123	UNF	5/8 x 18	10	1,71
KC124	UNF	3/4 x 16	10	3,93
KC125	UNF	7/8 x 14	10	5,66
KC126	UNF	1" x 12	10	5,66
x				
KC130	BSW	1/8 x 40	100	1,01
KC131	BSW	3/16 x 24	100	1,01
KC132	BSW	1/2 x 12	100	1,29
KC133	BSW	1/4 x 20	100	0,42
KC134	BSW	3/8 x 16	100	0,84
KC135	BSW	5/16 x 18	100	0,50
KC136	BSW	7/16 x 14	100	1,04
KC137	BSW	9/16 x 12	100	3,30
KC138	BSW	5/8 x 11	50	3,30
KC139	BSW	3/4 x 10	25	3,93
KC140	BSW	7/8 x 9	10	5,50
KC141	BSW	1" x 8	10	6,29
x				
KC142	BSF	3/16 x 32	100	1,01
KC143	BSF	1/2 x 16	100	1,91
KC144	BSF	1/4 26	100	0,70
KC145	BSF	3/8 20	100	1,07
KC146	BSF	5/16 22	100	0,79
KC147	BSF	7/16 18	100	1,83
KC148	BSF	9/16 16	100	3,15
KC149	BSF	5/8 14	50	3,15
KC150	BSF	3/4 12	50	3,93
KC151	BSF	7/8 11	25	5,50
KC152	BSF	1" 10	10	5,50
x				
KC153	BSP	1/8 28	100	0,63
KC154	BSP	1/4 19	100	0,93
KC155	BSP	3/8 19	50	1,10
KC156	BSP	1/2 14	25	1,42
KC157	BSP	5/8 14	10	3,54
KC158	BSP	3/4 14	5	3,54
KC159	BSP	7/8 14	5	10,86
KC160	BSP	1" 11	5	10,86

Prazo de entrega sujeito a confirmação

Mandril cilíndrico manual DIN206-B HSS



Código	Ø	l mm	L mm	PCS	€
MQ1003	2,50	29	55	1	15,06
MQ1079	3,20	38	76	1	15,06
MQ1007	3,50	35	71	1	15,79
MQ1009	4,00	38	76	1	15,06
MQ1013	5,00	44	87	1	15,72
MQ1017	6,00	47	93	1	15,72
MQ1025	8,00	58	115	1	16,62
MQ1033	10,00	66	133	1	20,01
MQ1037	11,00	71	142	1	22,36
MQ1041	12,00	76	152	1	32,44
MQ1043	13,00	76	152	1	41,40
MQ1045	14,00	81	163	1	44,24
MQ1052	17,50	87	165	1	67,94
MQ1056	19,50	93	188	1	77,69
MQ1075	29,00	124	247	1	111,62

Venda até ao fim de existência

Mandril cilíndrico p/máquina DIN212 HSS-CO



Código	Ø	l mm	L mm	PCS	€
MQ1111	7,00	31	109	1	16,71
MQ1112	7,50	31	109	1	18,15
MQ1124	14,00	47	160	1	42,93
MQ1129	19,00	58	189	1	64,12

Venda até ao fim de existência



Mandril cabo cónico p/máquina DIN208 HSS-CO

Código	Ø	l mm	L mm	PCS	€
MQ1500	4,00	19	129	1	42,68
MQ1501	5,00	23	133	1	30,93
MQ1502	6,00	26	138	1	31,36
MQ1503	7,00	31	150	1	31,92
MQ1505	9,00	36	162	1	34,96
MQ1506	10,00	38	168	1	33,13
MQ1507	11,00	41	175	1	33,56
MQ1508	12,00	44	182	1	34,23
MQ1509	13,00	44	182	1	44,09
MQ1514	18,00	56	219	1	60,34
MQ1515	19,00	58	223	1	63,18

Venda até ao fim de existência



Mandril extensível HSS com guia

Código	Ø	l mm	L mm	PCS	€
MQ2100	8,00 - 9,00	39	175	1	100,17
MQ2101	9,00 - 10,00	39	185	1	100,17
MQ2102	10,00 - 11,00	45	195	1	100,17
MQ2103	11,00 - 12,00	45	200	1	100,17
MQ2104	12,00 - 13,50	48	220	1	102,17
MQ2105	13,50 - 15,50	58	243	1	106,24
MQ2106	15,50 - 18,00	69	274	1	111,27
MQ2107	18,00 - 21,00	75	300	1	118,31
MQ2108	21,00 - 24,00	80	320	1	135,34
MQ2109	24,00 - 27,50	90	350	1	151,46
MQ2110	27,50 - 31,50	100	385	1	170,52
MQ2111	31,50 - 37,00	110	424	1	234,97
MQ2112	37,00 - 45,00	130	490	1	329,05
MQ2113	45,00 - 55,00	145	600	1	471,63

L mm - comprimento total l mm - comprimento da navalha Ø capacidade

MASTER-OIL MULTIUSOS

Maquinção de uso geral

Código		PCS	€
OLEO01	5 Litros	1	35,94
OLEO02	20 Litros	1	133,92
OLEO03	205 Litros	1	1,271,52



DESCRIÇÃO E APLICAÇÕES

O MASTER-OIL MULTIUSOS é um fluido de corte emulsionável para operações de maquinção geral, torneado, serrado, fresagem, etc. Em todo o tipo de materiais de aço, alumínio, latão e suas ligas, dando um alto nível de acabamento superficial.

PROPRIEDADES

As emulsões de MASTER-OIL MULTIUSOS têm uma elevada estabilidade com águas até 50° HF de dureza. Proporcionam uma boa refrigeração da zona de corte, alargando a vida das máquinas e peças maquinadas.

Tem bom poder anticorrosivo a partir de concentrações 3%, estando isento de nitratos, dando uma excelente protecção às máquinas e peças maquinadas.

Contem bactericidas específicos que melhoram a resistência a fermentação das emulsões. A sua baixa tensão superficial confere-lhe boas qualidades humidificantes com o que se melhora a evacuação de calor.

MASTER-OIL EXTRA

Maquinção de uso geral
Indicado para serras de fita

Código		PCS	€
OLEO10	5 Litros	1	39,31
OLEO11	20 Litros	1	152,66
OLEO12	205 Litros	1	1,362,70



DESCRIÇÃO E APLICAÇÕES

O MASTER-OIL EXTRA é um fluido de corte emulsionável em água de carácter bacteriostático. Utiliza-se para operações de maquinção geral de aços e aluminios. Indicado especialmente para serras de fita.

PROPRIEDADES

MASTER-OIL EXTRA possui uma emulsão branca opaca que proporciona uma boa refrigeração na zona de corte. Forma uma micro-emulsão de elevada estabilidade com águas até 35° HF de dureza.

Tem bom poder anticorrosivo a partir de concentrações de 3%, estando isento de nitratos, dando uma excelente protecção às máquinas e peças maquinadas.

As emulsões de MASTER-OIL EXTRA pelo seu carácter bacteriostático, pela sua baixa concentração de uso, sua larga duração, conservação de ferramentas e aforro de bactericidas e manutenção, obtém-se uma grande economia comparando-as com emulsões de produtos convencionais.

MASTER-OIL CUT

Maquinção de trabalhos difíceis

Código		PCS	€
OLEO20	5 Litros	1	38,81
OLEO21	20 Litros	1	135,20
OLEO22	205 Litros	1	1,359,97



DESCRIÇÃO E APLICAÇÕES

O MASTER-OIL CUT é um óleo de corte especial para operações severas de maquinção de aços altamente ligados de difícil maquinção, assim como aluminios e suas ligas.

Especialmente indicado para operações de furação profunda, escariado, roscagem em aços de média e alta dureza.

PROPRIEDADES

O MASTER-OIL CUT é um produto especialmente formulado com aditivos extrema pressão e matéria gordurosa, totalmente isento de cloro, que confere excelentes condições de lubrificação durante a operação de corte, a velocidades elevadas, e em condições de trabalho severas.

O MASTER-OIL CUT mantem um perfeito equilíbrio lubri-refrigerante durante a operação de corte a altas velocidades onde se dão regimes de refrigeração limites, gerando-se pontualmente uma grande quantidade de calor.

MASTER-OIL MICRO-PULVERIZAÇÃO
Maquinação por sistema de pulverização

Código		PCS	€
OLEO25	5 Litros	1	60,72
OLEO26	20 Litros	1	220,48
OLEO27	205 Litros	1	1,941,47



DESCRIÇÃO E APLICAÇÕES

O MASTER-OIL MICRO-PULVERIZAÇÃO é um óleo sintético de baixa viscosidade, isento de cloro. Está especialmente desenhado para operações de maquinação por micro-pulverização (MQL) directa na zona de contacto metal ferramenta. O produto é ideal para o corte de aço e alumínio com serras de fita e discos a altas velocidades.

PROPRIEDADES

MASTER-OIL MICRO-PULVERIZAÇÃO proporciona excelente lubrificação na zona de corte, melhorando o rendimento das ferramentas e o acabamento superficial das peças maquinadas. Na formulação são utilizadas bases e aditivos especiais que o fazem um produto biodegradável e de muito baixa toxicidade. Não contendo cloro, metais pesados, silicões e outras substâncias que possam afectar as pessoas e o meio ambiente.

MASTER-OIL CUT ALUMÍNIO
POLIMENTO OU RECTIFICAÇÃO DE QUALQUER TIPO DE METAIS, INDICADO PARA ALUMÍNIO

Código		PCS	€
OLEO35	5 Litros	1	38,81



DESCRIÇÃO E APLICAÇÕES

O MASTER-OIL CUT ALUMÍNIO é um óleo formulado para polimento ou rectificação de qualquer tipo de metais, por meio de mós de diamante ou abrasivos. Especialmente indicado para alumínio. A incorporação de gordura na fórmula permite um polimento perfeito sem riscar o metal.

PROPRIEDADES

MASTER-OIL CUT ALUMÍNIO é constituído essencialmente por misturas de óleos minerais altamente refinados e solventes, humectantes e antioxidantes com aditivos. O óleo mineral utilizado é na sua natureza altamente parafínico e refinado, de modo que os problemas na pele dos trabalhadores são evitados. A baixa viscosidade, juntamente com o seu detergente de alta potencia, permite o uso em afiação e polimento em operações sem embolamento dos dentes, fitas, lixas, etc. É um óleo devido à incorporação de surfactantes muito energéticos, tem a propriedade de ser lavável com água, tornando-se assim num produto muito adequado para polimento de perfis de alumínio, obtendo por essa razão um desengordurante de volta perfeita.



MASTER-OIL
SPRAY ÓLEO DE CORTE

Código		€
OLEO50	400 ml	11,02

O MASTER-OIL SPRAY ÓLEO DE CORTE é ideal para roscar, furar, fresar e escarear. Prolonga a vida da ferramenta, optimiza a saída da limalha e melhora o rendimento de corte e a qualidade superficial do acabamento.

Expositor Óleo Spray

Composição: 9 sprays
Código: OLEO99
99,22 €

+ oferta manual



Seleção de grupo de materiais:

- * Aços
- * Aços inoxidáveis
- * Fundição
- * Materiais não ferrosos
- * Ligas termoresistentes
- * Materiais tratados

P
Aço

Aço sem liga
Aço com liga
Aço tratado
Aço de construção

M
Aço Inoxidável

Austenitico CrNi
Martensitico Cr
Ferrítico Cr
Duplo

K
Fundição

Fundição com grafite
Laminar
Ferro sintetizado
Fundição nodular
Ferro fundido

N
Metais não ferrosos

Ligas de alumínio
Ligas de cobre

Metais não metálicos

Plásticos e outros

S
Ligas termoresistentes

Ligas Ti
Ligas de base Ni-Co

H
Materiais tratados

Aço tratado
Fundição
Fundição tratada



- CC Geometria

O quebra aparas CC combinado com a performance das Cermets, está preparado para um eficiente controlo das aparas em acabamentos e grandes operações de maquinação. Aconselhado para acabamentos de aços e ferro fundido.

Principal área de aplicação:
* Profundidade de corte (Ap): 0,2 - 1,5mm * Avanço (f): 0,05 - 0,4mm

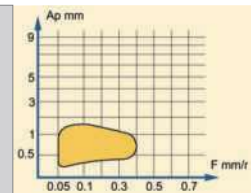

- FC Geometria

Os quebra aparas FC foram projectados para operações de acabamento leves de alta velocidade, para um avanço 0,08mm a 0,3mm e para uma profunda de corte entre (0,2 a 2,5mm).

Principal área de aplicação:
* Profundidade de corte (Ap): 0,2 - 2,5mm * Avanço (f): 0,08 - 0,3mm

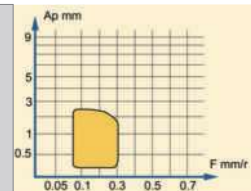

- FMC Geometria

Pastilha com dupla face para semi-acabado. Ângulo de corte de 12° positivo que reduz as forças de corte na maquinação na peça. Quebra aparas com perfil diferencial que reduz a zona de contacto a qual permite uma melhoria da difusão térmica. Excelente resultado em todo o tipo de aços.

Principal área de aplicação:
* Profundidade de corte (Ap): 0,5 - 2,5mm * Avanço (f): 0,05 - 0,25mm

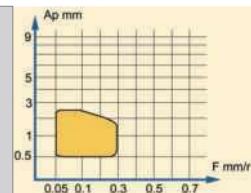

- MC Geometria

Os quebra aparas MC proporcionam um ângulo de incidência positivo em relação à base, para uma melhor resistência da aresta em aplicações e mecanizações médias numa grande variedade de materiais. Recomendada para aplicações gerais em todo o tipo de aços.

Principal área de aplicação:
* Profundidade de corte (Ap): 1,0 - 3,5mm * Avanço (f): 0,15 - 0,35mm

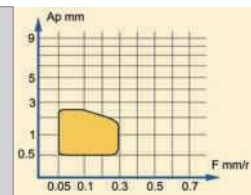

- RC Geometria

O quebra aparas mais forte para pastilhas de dupla face. O quebra aparas RC é adequado para alta velocidade e profundidade de corte onde normalmente é requerido uma pastilha de face de corte única. Este quebra aparas tem uma vasta área negativa em forma de T, o qual lhe dá um gume de corte muito forte.

Principal área de aplicação:
* Profundidade de corte (Ap): 1,5 - 5mm * Avanço (f): 0,3 - 0,5mm

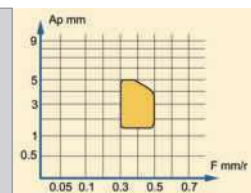

- 33 Geometria

Esta geometria proporciona controlo das aparas em acabados e semi-acabados. O ângulo de ataque positivo, reduz as forças de corte e o consumo de energia. Também pode ser usado em aços de liga leve e inoxidáveis.

Principal área de aplicação:
* Profundidade de corte (Ap): 0,5 - 4mm * Avanço (f): 0,15 - 0,4mm

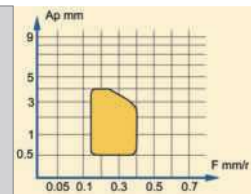

- AL Geometria

Esta geometria é indicada pra torneamento de alumínio. ligas leves, metais não ferrosos, metais fusíveis, plásticos reforçados com fibra de vidro, cartão laminado, carbono e cerâmica fina.

Principal área de aplicação:
* Profundidade de corte (Ap): 1 - 10mm * Avanço (f): 0,1 - 0,75mm

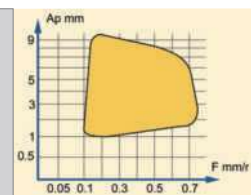

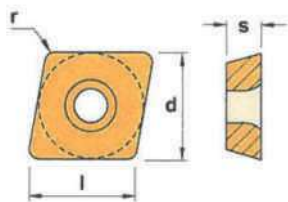

- P** Aços
- M** Aços inoxidáveis
- K** Ferro fundido
- N** Metais não ferrosos

CCMT

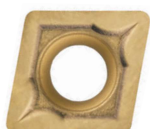

Código	Referência	Dureza	l	s	d	r	PCS	€
MP0001	CCMT 060202	TN-15	6,45	2,38	6,35	0,2	10	6,90
MP0002	CCMT 060204	TN-15	6,45	2,38	6,35	0,4	10	6,90
MP0003	CCMT 060204	TN-35	6,45	2,38	6,35	0,4	10	6,90
MP0004	CCMT 09T304	TN-15	9,65	3,97	9,52	0,4	10	7,91
MP0005	CCMT 09T304	TN-35	9,65	3,97	9,52	0,4	10	7,91
MP0006	CCMT 09T308	TN-15	9,65	3,97	9,52	0,8	10	7,91
MP0007	CCMT 09T308	TN-35	9,65	3,97	9,52	0,8	10	7,91
MP0008	CCMT 120408	TN-15	12,90	4,76	12,70	0,8	10	10,47

CNMG-CC



Código	Referência	Dureza	l	s	d	r	PCS	€
MP0100	CNMG120404-CC	NC-25	12,90	4,76	12,70	0,4	10	12,02
MP0101	CNMG120408-CC	NC-25	12,90	4,76	12,70	0,8	10	12,02

CNMG-FC



Código	Referência	Dureza	l	s	d	r	PCS	€
MP0200	CNMG120404-FC	TN-15	12,90	4,76	12,70	0,4	10	9,76
MP0201	CNMG120404-FC	TN-30	12,90	4,76	12,70	0,4	10	9,76

CNMG-MC



Código	Referência	Dureza	l	s	d	r	PCS	€
MP0300	CNMG120408-MC	TN-15	12,90	4,76	12,70	0,8	10	9,76

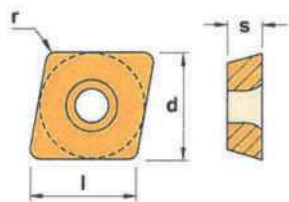

- P** Aços
- M** Aços inoxidáveis
- K** Ferro fundido
- N** Metais não ferrosos

CNMG-FC

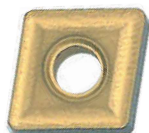

Código	Referência	Dureza	l	s	d	r	PCS	€
MP0400	CNMG090304-FC	TN-15	9,65	3,18	9,52	0,4	10	9,76
MP0401	CNMG090308-FC	TN-15	9,65	3,18	9,52	0,4	10	9,76
MP0402	CNMG120408-FC	TN-15	9,65	3,18	9,52	0,8	10	9,76
MP0403	CNMG120412-FC	TN-15	9,65	3,18	9,52	1,2	10	9,76

CNMG-RC



Código	Referência	Dureza	l	s	d	r	PCS	€
MP0500	CNMG120408-RC	TN-15	12,90	4,76	12,70	0,8	10	9,76
MP0501	CNMG120412-RC	TN-30	12,90	4,76	12,70	1,2	10	9,76

Pastilhas KNUX / Negativas

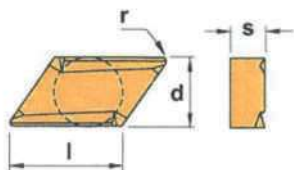

- P** Aços
- M** Aços inoxidáveis
- K** Ferro fundido
- N** Metais não ferrosos

KNUX



Código	Referência	Dureza	l	s	d	r	PCS	€
MP0600	KNUX 160405L-21	TN-15	16,00	4,76	9,52	0,5	10	12,57
MP0601	KNUX 160405L-32	TN-15	16,00	4,76	9,52	0,5	10	12,57
MP0602	KNUX 160405R-21	TN-15	16,00	4,76	9,52	0,5	10	12,57
MP0603	KNUX 160405R-32	TN-15	16,00	4,76	9,52	0,5	10	12,57
MP0604	KNUX 160410L-21	TN-30	16,00	4,76	9,52	1,0	10	12,57
MP0605	KNUX 160410L-32	TN-30	16,00	4,76	9,52	1,0	10	12,57
MP0606	KNUX 160410R-21	TN-30	16,00	4,76	9,52	1,0	10	12,57
MP0607	KNUX 160410R-32	TN-30	16,00	4,76	9,52	1,0	10	12,57

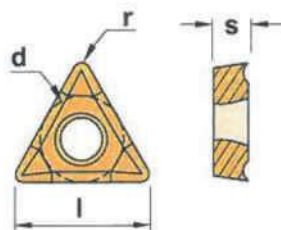

- P** Aços
- M** Aços inoxidáveis
- K** Ferro fundido
- N** Metais não ferrosos

TCMT



Código	Referência	Dureza	l	s	d	r	PCS	€
MP0700	TCMT 110204	KM -15	11,00	2,38	6,35	0,4	10	5,59
MP0701	TCMT 110204	PM -25	11,00	2,38	6,35	0,4	10	5,59
MP0702	TCMT 110204	T N -15	11,00	2,38	6,35	0,4	10	6,83
MP0703	TCMT 110204	TIN -25	11,00	2,38	6,35	0,4	10	6,83
MP0704	TCMT 110204	T N -35	11,00	2,38	6,35	0,6	10	6,83
MP0705	TCMT 16T304	PM -25	16,50	3,97	9,52	0,4	10	7,63
MP0706	TCMT 16T304	KN -15	16,50	3,97	9,52	0,4	10	7,63
MP0707	TCMT 16T304	T N -30	16,50	3,97	9,52	0,4	10	9,46
MP0708	TCMT 16T304	T N -35	16,50	3,97	9,52	0,4	10	9,46
MP0710	TCMT 16T308	PM -25	16,50	3,97	9,52	0,8	10	7,63
MP0711	TCMT 16T308	T N -15	16,50	3,97	9,52	0,8	10	9,46
MP0712	TCMT 16T308	T N -30	16,50	3,97	9,52	0,8	10	9,46
MP0713	TCMT 16T308	T N -35	16,50	3,97	9,52	0,8	10	9,46

TPMR-33



Código	Referência	Dureza	l	s	d	r	PCS	€
MP0800	TPMR 110304-33	TN-15	11,00	3,18	6,35	0,4	10	6,17
MP0801	TPMR 110308-33	TN-20	11,00	3,18	6,35	0,8	10	6,17
MP0802	TPMR 160304-33	TN-15	16,50	3,18	9,52	0,4	10	8,42
MP0803	TPMR 160304-33	TN-30	16,50	3,18	9,52	0,4	10	8,42
MP0804	TPMR 160308-33	TN-15	16,50	3,18	9,52	0,8	10	8,42
MP0805	TPMR 160308-33	TN-30	16,50	3,18	9,52	0,8	10	8,42

TPUN



Código	Referência	Dureza	l	s	d	r	PCS	€
MP0900	TPUN 110304E	PM -25	11,00	3,18	6,35	0,4	10	4,42
MP0901	TPUN 110304E	TIN -25	11,00	3,18	6,35	0,4	10	5,71
MP0902	TPUN 110308E	PM -25	11,00	3,18	6,35	0,8	10	4,42
MP0903	TPUN 110308E	TIN -25	11,00	3,18	6,35	0,8	10	5,71
MP0904	TPUN 160304E	PM -25	16,50	3,18	9,52	0,4	10	5,31
MP0905	TPUN 160304E	TIN -25	16,50	3,18	9,52	0,4	10	7,47
MP0906	TPUN 160308E	PM -25	16,50	3,18	9,52	0,8	10	5,31
MP0907	TPUN 160308E	TIN -25	16,50	3,18	9,52	0,8	10	7,47
MP0908	TPUN 160312E	PM -25	16,50	3,18	9,52	1,2	10	7,02
MP0909	TPUN 160312E	TIN -25	16,50	3,18	9,52	1,2	10	8,69

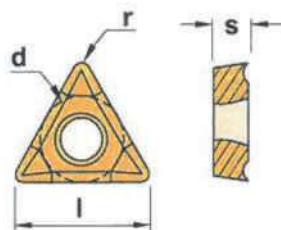

- P Aços
- M Aços inoxidáveis
- K Ferro fundido
- N Metais não ferrosos

TNMG-CC



Código	Referência	Dureza	l	s	d	r	PCS	€
MP1000	TNMG 160404-CC	NC-25	16,50	4,76	9,52	0,4	10	10,53
MP1001	TNMG 160408-CC	NC-25	16,50	4,76	9,52	0,8	10	10,53

TNMG-FC



Código	Referência	Dureza	l	s	d	r	PCS	€
MP1100	TNMG 160404-FC	TN-15	16,50	4,76	9,52	0,4	10	8,60
MP1101	TNMG 160404-FC	TN-30	16,50	4,76	9,52	0,4	10	8,60

TNMG-MC



Código	Referência	Dureza	l	s	d	r	PCS	€
MP1200	TNMG 160408-MHC	TN-15	16,50	4,76	9,52	0,8	10	8,60
MP1201	TNMG 160408-MHC	TN-30	16,50	4,76	9,52	0,8	10	8,60

TNMG-MHC



Código	Referência	Dureza	l	s	d	r	PCS	€
MP1300	TNMG 160408-MHC	TN-30	16,50	4,76	9,52	0,8	10	8,60
MP1301	TNMG 160412-MHC	TN-30	16,50	4,76	9,52	1,2	10	8,60
MP1302	TNMG 220408-MHC	TN-30	22,00	4,76	12,70	0,8	10	11,96
MP1303	TNMG 220412-MHC	TN-30	22,00	4,76	12,70	1,2	10	11,96

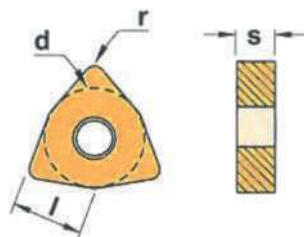

- P** Aços
- M** Aços inoxidáveis
- K** Ferro fundido
- N** Metais não ferrosos



WNMG-FC

Código	Referência	Dureza	l	s	d	r	PCS	€
MP1400	WNMG 080404-FC	TN-15	8,14	4,76	12,70	0,4	10	11,32
MP1401	WNMG 080404-FC	TN-30	8,14	4,76	12,70	0,4	10	11,32



WNMG-MC

Código	Referência	Dureza	l	s	d	r	PCS	€
MP1500	WNMG 080408-MC	TN-15	8,14	4,76	12,70	0,8	10	8,60
MP1501	WNMG 080408-MC	TN-30	8,14	4,76	12,70	0,8	10	8,60



WNMG-MHC

Código	Referência	Dureza	l	s	d	r	PCS	€
MP1600	WNMG 060404-MHC	TN-15	6,45	4,76	9,52	0,4	10	11,32
MP1601	WNMG 060408-MHC	TN-20	6,45	4,76	9,52	0,8	10	11,32
MP1602	WNMG 080408-MHC	TN-20	8,14	4,76	12,70	0,8	10	11,32
MP1603	WNMG 080408-MHC	TN-30	8,14	4,76	12,70	0,8	10	11,32
MP1604	WNMG 080412-MHC	TN-20	8,14	4,76	12,70	1,2	10	11,32

PWLN 95°

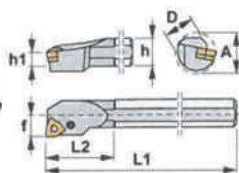

Aplicações:
Ferro de torno para torneamento interior para mecanizações gerais, desbaste, semi-acabados e acabados.

Referência	D	h	h1	L1	L2	f	A	Pastilha	PCS	R (direito)		L (esquerdo)	
										Código	€	Código	€
S16R PWLN 06	16	15	7,5	200	24	11	20	WNM..0604..	1	MP2000	196,00	MP2050	196,00
S20S PWLN 06	20	18	9,0	250	36	13	27	WNM..0604..	1	MP2001	154,67	MP2051	154,67
S25T PWLN 08	25	23	11,5	300	40	17	31	WNM..0804..	1	MP2002	161,33	MP2052	161,33
S32U PWLN 08	32	30	15,0	350	50	22	39	WNM..0804..	1	MP2003	209,33	MP2053	209,33

SCLC 95°

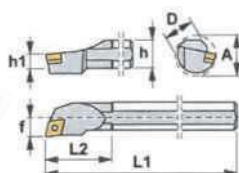

Aplicações:
Ferro de torno para torneamento interior para mecanizações gerais, desbaste, semi-acabados e acabados. Para ferros de torno de pastilha negativa, ver a referência PCLN.

Referência	D	h	h1	L1	L2	f	A	Pastilha	PCS	R (direito)		L (esquerdo)	
										Código	€	Código	€
S08K SCLC 06	8	7	3,5	125	16	5	11	CC..0602..	1	MP2100	76,00	MP2150	76,00
S10M SCLC 06	10	9	4,5	150	25	7	13	CC..0602..	1	MP2108	76,00	MP2151	76,00
S12M SCLC 06	12	11	5,5	150	25	9	16	CC..0602..	1	MP2102	76,00	MP2152	76,00
S16R SCLC 09	16	15	7,5	200	30	11	20	CC..09T3..	1	MP2109	80,00	MP2153	80,00
S20S SCLC 09	20	18	9,0	250	35	13	24	CC..09T3..	1	MP2104	113,33	MP2154	113,33
S25T SCLC 12	25	23	11,5	300	40	17	31	CC..1204..	1	MP2105	122,67	MP2155	122,67
S32U SCLC 12	32	30	15,0	350	50	22	39	CC..1204..	1	MP2106	164,10	MP2156	164,10
S40V SCLC 12	40	37	18,5	400	60	27	48	CC..1204..	1	MP2107	208,25	MP2157	208,25

CTUP 93°

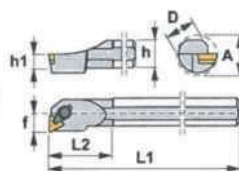

Aplicações:
Ferro de torno para torneamento interior para todo o tipo de materiais. A peça a mecanizar deve ser estabilizada.

Referência	D	h	h1	L1	L2	f	A	Pastilha	PCS	R (direito)		L (esquerdo)	
										Código	€	Código	€
S16R CTUP 11	16	15	7,5	200	30	11	20	TP..1103..	1	MP2206	117,33	MP2250	117,33
S20S CTUP 11	20	18	9,0	250	35	13	24	TP..1603..	1	MP2201	148,00	MP2251	148,00
S16R CTUP 16	16	15	7,5	200	30	11	20	TP..1103..	1	MP2202	125,10	MP2252	125,10
S20S CTUP 16	20	18	9,0	250	35	13	24	TP..1603..	1	MP2203	148,00	MP2253	148,00
S25T CTUP 16	25	23	11,5	300	40	17	31	TP..1603..	1	MP2204	162,67	MP2254	162,67
S32U CTUP 16	32	30	15,0	350	50	22	39	TP..1603..	1	MP2205	209,33	MP2255	209,33

PCLN 95°

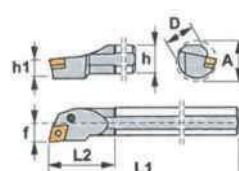

Aplicações:
Ferro de torno para torneamento interior para mecanizações gerais, desbaste, semi-acabados e acabados. Para máquinas de baixa potência e peças pequenas, optar por ferros de torneamento interior com a referência SCLC.

Referência	D	h	h1	L1	L2	f	A	Pastilha	PCS	R (direito)		L (esquerdo)	
										Código	€	Código	€
S20S PCLN 09	20	18	9,0	250	29	13	25	CN..0903..	1	MP2300	154,67	MP2350	154,67
S25T PCLN 09	25	23	11,5	300	33	17	32	CN..0903..	1	MP2301	213,33	MP2351	213,33
S25T PCLN 12	25	23	11,5	300	40	17	31	CN..1204..	1	MP2302	161,33	MP2352	161,33
S32U PCLN 12	32	30	15,0	350	50	22	39	CN..1204..	1	MP2303	185,33	MP2353	185,33
S40V PCLN 12	40	37	18,5	400	60	27	48	CN..1204..	1	MP2304	240,92	MP2354	240,92

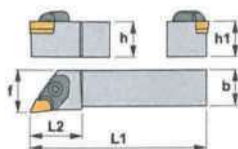

Aplicações:
Ferro de torno de cilindrar para operações de semi-acabado e acabado.

CKJN 93°

Referência	h=h1	b	L1	L2	f	Pastilha	PCS	R (direito)		L (esquerdo)	
								Código	€	Código	€
CKJN 2020 K16	20	20	125	34	30	KNUX 1604..	1	MP2400	125,75	MP2450	125,75
CKJN 2525 M16	25	25	150	34	32	KNUX 1604..	1	MP2401	125,75	MP2451	125,75
CKJN 3232 P16	32	32	170	34	40	KNUX 1604..	1	MP2402	143,80	MP2452	143,80

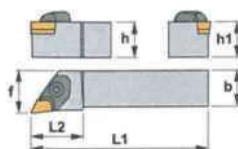

Aplicações:
Ferro de torno para torneamento exterior para todo o tipo de materiais. A peça a toronar deve ser estável.

CTGP 90°

Referência	h=h1	b	L1	L2	f	Pastilha	PCS	R (direito)		L (esquerdo)	
								Código	€	Código	€
CTGP 1616 H11	16	16	100	18	20	TP..1103..	1	MP2505	67,42	MP2550	67,42
CTGP 2020 K11	20	20	125	22	25	TP..1103..	1	MP2501	72,27	MP2551	72,27
CTGP 2020 K16	20	20	125	28	25	TP..1603..	1	MP2502	72,27	MP2552	72,27
CTGP 2525 M16	25	25	150	28	32	TP..1603..	1	MP2503	79,09	MP2553	79,09

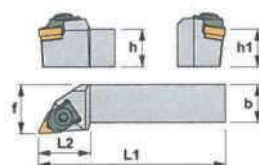
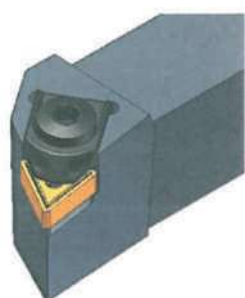

Aplicações:
Ferro de torno para torneamento exterior e copiar para aplicações gerais de desbaste semi-acabado e acabado. Não é indicado para pastilhas cermet, de cerâmica ou de qualidades K10 e P10.

MTJN 93°

Referência	h=h1	b	L1	L2	f	Pastilha	PCS	R (direito)		L (esquerdo)	
								Código	€	Código	€
MTJN 2020 K16	20	20	125	34	25	TNM..1604..	1	MP2600	74,66	MP2650	74,66
MTJN 2525 M16	25	25	150	34	32	TNM..1604..	1	MP2604	79,07	MP2651	79,07
MTJN 2525 M22	25	25	150	38	32	TNM..2204..	1	MP2605	79,07	MP2652	79,07
MTJN 3232 P22	32	32	170	42	40	TNM..2204..	1	MP2603	86,50	MP2653	86,50



D2:17 L1:27,5 $\alpha:8^\circ$ $\beta:30^\circ$

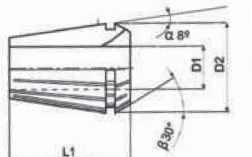

Pinças de precisão ER 16 - DIN6499-B

Código	ER	Capacidade D1	PCS	€	
MP8000	ER 16	1,0	0,5	1	22,40
MP8001	ER 16	1,5	1,0	1	22,40
MP8002	ER 16	2,0	1,0	1	22,40
MP8003	ER 16	2,5	2,0	1	22,40
MP8004	ER 16	3,0	2,0	1	22,40
MP8005	ER 16	3,5	3,0	1	18,70
MP8006	ER 16	4,0	3,0	1	18,70
MP8007	ER 16	4,5	3,0	1	18,70
MP8008	ER 16	5,0	4,0	1	18,70
MP8009	ER 16	6,0	5,0	1	18,70
MP8010	ER 16	7,0	6,0	1	18,70
MP8011	ER 16	8,0	7,0	1	18,70
MP8012	ER 16	9,0	8,0	1	18,70
MP8013	ER 16	10,0	9,0	1	18,70



D2:26 L1:34 $\alpha:8^\circ$ $\beta:30^\circ$

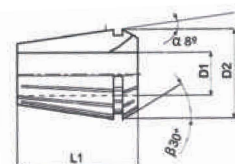

Pinças de precisão ER 25 - DIN6499-B

Código	ER	Capacidade D1	PCS	€	
MP8050	ER 25	1,0	0,5	1	24,30
MP8051	ER 25	2,0	1,5	1	24,30
MP8052	ER 25	3,0	2,0	1	18,70
MP8053	ER 25	4,0	3,0	1	18,70
MP8054	ER 25	5,0	4,0	1	18,70
MP8055	ER 25	6,0	5,0	1	18,70
MP8056	ER 25	7,0	6,0	1	18,70
MP8057	ER 25	8,0	7,0	1	18,70
MP8058	ER 25	9,0	8,0	1	18,70
MP8059	ER 25	10,0	9,0	1	18,70
MP8060	ER 25	11,0	10,0	1	18,70
MP8061	ER 25	12,0	11,0	1	18,70
MP8062	ER 25	13,0	12,0	1	18,70
MP8063	ER 25	14,0	13,0	1	18,70
MP8064	ER 25	15,0	14,0	1	18,70
MP8065	ER 25	16,0	15,0	1	18,70

Outras medidas sob consulta





D2:33 L1:40 $\alpha:8^\circ$ $\beta:30^\circ$

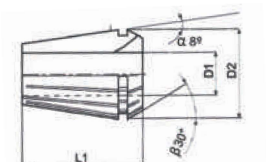

D2:41 L1:46 $\alpha:8^\circ$ $\beta:30^\circ$

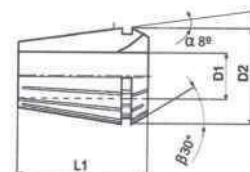

Pinças de precisão ER 32 - DIN6499-B

Código	ER 32	Capacidade D1	PCS	€
MP8100	ER 32	2,0 - 1,0	1	16,80
MP8101	ER 32	3,0 - 2,0	1	16,80
MP8102	ER 32	4,0 - 3,0	1	16,80
MP8103	ER 32	5,0 - 4,0	1	16,80
MP8104	ER 32	6,0 - 5,0	1	16,80
MP8105	ER 32	7,0 - 6,0	1	16,80
MP8106	ER 32	8,0 - 7,0	1	16,80
MP8107	ER 32	9,0 - 8,0	1	16,80
MP8108	ER 32	10,0 - 9,0	1	16,80
MP8109	ER 32	11,0 - 10,0	1	16,80
MP8110	ER 32	12,0 - 11,0	1	16,80
MP8111	ER 32	13,0 - 12,0	1	16,80
MP8112	ER 32	14,0 - 13,0	1	16,80
MP8113	ER 32	15,0 - 14,0	1	16,80
MP8114	ER 32	16,0 - 15,0	1	16,80
MP8115	ER 32	17,0 - 16,0	1	16,80
MP8116	ER 32	18,0 - 17,0	1	16,80
MP8117	ER 32	19,0 - 18,0	1	16,80
MP8118	ER 32	20,0 - 19,0	1	16,80

Pinças de precisão ER 40 - DIN6499-B

Código	ER 40	Capacidade D1	PCS	€
MP8150	ER 40	3,0 - 2,0	1	24,15
MP8151	ER 40	4,0 - 3,0	1	24,30
MP8152	ER 40	5,0 - 4,0	1	24,30
MP8153	ER 40	6,0 - 5,0	1	24,30
MP8154	ER 40	7,0 - 6,0	1	24,30
MP8155	ER 40	8,0 - 7,0	1	24,30
MP8156	ER 40	9,0 - 8,0	1	24,30
MP8157	ER 40	10,0 - 9,0	1	24,30
MP8158	ER 40	11,0 - 10,0	1	24,30
MP8159	ER 40	12,0 - 11,0	1	24,30
MP8160	ER 40	13,0 - 12,0	1	24,30
MP8161	ER 40	14,0 - 13,0	1	24,30
MP8162	ER 40	15,0 - 14,0	1	24,30
MP8163	ER 40	16,0 - 15,0	1	24,30
MP8164	ER 40	17,0 - 16,0	1	24,30
MP8165	ER 40	18,0 - 17,0	1	24,30
MP8166	ER 40	19,0 - 18,0	1	24,30
MP8167	ER 40	20,0 - 19,0	1	24,30
MP8168	ER 40	21,0 - 20,0	1	24,30
MP8169	ER 40	22,0 - 21,0	1	24,30
MP8170	ER 40	23,0 - 22,0	1	24,30
MP8171	ER 40	24,0 - 23,0	1	24,30
MP8172	ER 40	25,0 - 24,0	1	24,30
MP8173	ER 40	26,0 - 25,0	1	36,40
MP8174	ER 40	27,0 - 26,0	1	36,40
MP8175	ER 40	28,0 - 27,0	1	36,40
MP8176	ER 40	29,0 - 28,0	1	36,40
MP8177	ER 40	30,0 - 29,0	1	36,40

Outras medidas sob consulta



Jogo ER16 de 1 a 10

Composição: 10 peças Código: MP8200



140,00 €

Jogo ER25 de 2 a 16

Composição: 15 peças Código: MP8201



218,76 €

Jogo ER32 de 3 a 20

Composição: 18 peças Código: MP8202



280,00 €

Jogo ER40 de 3 a 26

Composição: 24 peças Código: MP8203



430,50 €

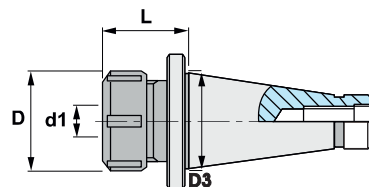

Cones para pinças de precisão ISO40 - DIN69871

Código	Pinça DIN6499	L	d1	D	D3	PCS	€
MP8500	ER 16	70	0,5 - 10	32		1	72,00
MP8501	ER 16	100	0,5 - 10	32	28	1	72,00
MP8502	ER 25	70	1 - 16	42		1	72,00
MP8503	ER 25	100	1 - 16	42	45	1	72,00
MP8504	ER 32	70	2 - 20	50		1	72,00
MP8505	ER 32	100	2 - 20	50	48	1	72,00
MP8506	ER 40	70	3 - 30	63		1	80,00
MP8507	ER 40	100	3 - 30	63	50	1	80,00

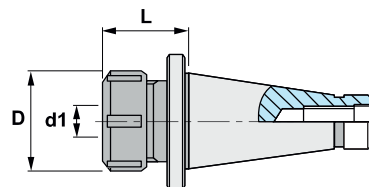

Cones para pinças de precisão ISO40 - B6339 MAS403 BT

Código	Pinça DIN6499	L	d1	D	PCS	€
MP8550	ER 16	70	0,5 - 10	32	1	72,00
MP8551	ER 25	70	1 - 16	42	1	72,00
MP8552	ER 32	70	2 - 20	50	1	72,00
MP8553	ER 40	70	3 - 30	63	1	80,00

Outras medidas sob consulta



Para furos precisos em chapa de aço inoxidável e materiais plásticos

Rosca métrica HSS

Código	Medida	S	PCS	€
MRS001	10	1,5	1	53,01
MRS002	11	1,5	1	53,01
MRS003	12	1,5	1	53,01
MRS004	12,5 Pg 7/M 12x1,5	1,5	1	53,01
MRS005	13	1,5	1	53,01
MRS006	14	1,5	1	59,38
MRS007	15	1,5	1	59,38
MRS008	15,2 Pg 9	1,5	1	59,38
MRS009	16	2	1	43,64
MRS010	16,5 M 16x1,5	2	1	43,64
MRS011	17	2	1	43,64
MRS012	18	2	1	43,64
MRS013	18,6 Pg 11	2	1	46,42
MRS014	19	2	1	46,42
MRS015	20	2	1	46,42
MRS016	20,5 Pg 13,5/M 20x1,5	2	1	46,42
MRS017	21	2	1	46,42
MRS018	22	2	1	49,15
MRS019	22,5 Pg 16	2	1	49,15
MRS020	23	2	1	49,15
MRS021	24	2	1	49,15
MRS022	25	2	1	54,60
MRS023	25,5 M 25x1,5	2	1	54,60
MRS024	26	2	1	54,60
MRS025	27	2	1	54,60
MRS026	28	2	1	57,40
MRS027	28,3 Pg 21	2	1	57,40
MRS028	29	2	1	57,40
MRS029	30	2	1	57,40
MRS030	30,5	2	1	58,81
MRS031	32	2	1	58,81
MRS032	32,5 M32x1,5	2	1	64,10
MRS033	33	2	1	64,10
MRS034	34	2	1	64,10
MRS035	35	2	1	64,10
MRS036	36	2	1	69,65
MRS037	37 Pg 29	2	1	69,65

Código	Medida	S	PCS	€
MRS038	38	2	1	69,65
MRS039	39	2	1	84,36
MRS040	40	2	1	84,36
MRS041	40,5 M 40x1,5	2	1	84,36
MRS042	41	2	1	84,36
MRS043	42	2	1	92,10
MRS044	43	2	1	92,10
MRS045	44	2	1	92,10
MRS046	45	2	1	98,48
MRS047	46	2	1	98,48
MRS048	47 Pg 36	2	1	98,48
MRS049	48	2	1	106,69
MRS050	50	2	1	106,69
MRS051	50,5 M 50x1,5	3	1	116,73
MRS052	51	3	1	116,73
MRS053	52	3	1	116,73
MRS054	52,5	3	1	172,35
MRS055	54 Pg 42	3	1	124,92
MRS056	55	3	1	124,92
MRS057	57	3	1	133,13
MRS058	58	3	1	133,13
MRS059	59	3	1	133,13
MRS060	60 Pg 48	3	1	144,99
MRS061	60,5	3	1	214,30
MRS062	61	3	1	144,99
MRS063	62	3	1	144,99
MRS064	63	3	1	176,90
MRS065	63,5 M 63x1,5	3	1	176,46
MRS066	64	3	1	176,90
MRS067	65	3	1	176,90
MRS068	70	3,5	1	222,50
MRS069	73	3,5	1	260,80
MRS070	75	3,5	1	260,80
MRS071	80	3,5	1	310,96
MRS072	85	3,5	1	445,91
MRS073	89	3,5	1	453,21
MRS074	102	3,5	1	634,67

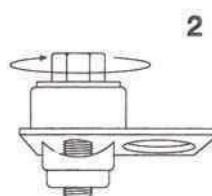
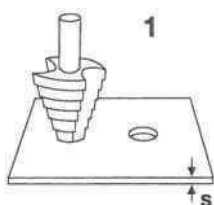



Utilização com chave



Jogo Pg 7 - Pg 29

Composição: 7 peças Código: MRS100

∅ 12,5 - 15,2 - 18,6 - 20,5 - 22,5 - 28,3 - 37

312,69 €



Utilização com chave



Jogo Pg 7 - Pg 48

Composição: 11 peças Código: MRS102

∅ 12,5 - 15,2 - 18,6 - 20,5 - 22,5 - 28,3 - 37
47 - 54 - 60

779,67 €

7 a 21mm

Jogo M 12 x 1,5 - M 63 x 1,5

Composição: 8 peças Código: MRS103

∅ 12,5 - 16,5 - 20,5 - 25,5 - 32,5 - 40,5
50,5 - 63,5

664,47 €

Parafusos com anilhas para saca bocados



Código	Medida	Capacidade	PCS	€
MRS210	M 6 x 1	10 - 13	1	12,48
MRS211	M 8 x 1	14 - 15,2	1	12,48
MRS212	M 10 x 1	16 - 38	1	14,04
MRS213	M 12 x 1,5	39 - 50	1	15,60
MRS214	M 16 x 1,5	52 - 62	1	20,28

Código	∅ mm	∅ "	PCS	€
MV2000	14	9/16	1	5,31
MV2001	16	5/8	1	5,31
MV2002	17	11/16	1	5,31
MV2003	19	3/4	1	5,31
MV2004	20	25/32	1	5,31
MV2005	21	13/16	1	5,31
MV2006	22	7/8	1	5,31
MV2007	23	14/16	1	5,31
MV2008	24	15/16	1	5,31
MV2009	25	1"	1	6,09
MV2010	27	1" 1/16	1	6,09
MV2011	28	3/32	1	6,09
MV2012	29	1" 1/18	1	6,09
MV2013	30	1" 3/16	1	6,09
MV2014	32	1" 1/4	1	6,09
MV2015	33	1" 5/16	1	6,51
MV2016	35	1" 3/8	1	6,51
MV2017	37	1" 7/16	1	6,51
MV2018	38	1" 1/2	1	7,31
MV2019	40	1" 9/16	1	7,31
MV2020	41	1" 5/8	1	7,31
MV2021	43	1" 11/16	1	7,31
MV2022	44	1" 3/4	1	7,75
MV2023	46	1" 13/16	1	7,75
MV2024	48	1" 7/8	1	7,75
MV2025	50	31/32	1	8,61
MV2026	51	2"	1	8,61
MV2027	52	2" 1/16	1	8,61
MV2028	54	2" 1/8	1	8,61
MV2029	57	2" 1/4	1	8,61
MV2030	59	2" 5/16	1	8,61
MV2031	60	2" 3/8	1	8,61
MV2032	63		1	10,55
MV2033	64	2" 1/2	1	10,55
MV2034	65	2" 3/16	1	10,55
MV2035	67	2" 5/8	1	10,55
MV2036	68	2" 11/16	1	10,55
MV2037	70	2" 3/4	1	11,38
MV2038	73	2" 7/8	1	11,38
MV2039	76	3"	1	11,38
MV2040	79	3" 1/8	1	11,38
MV2041	83	3" 1/4	1	11,38
MV2042	86	3" 3/8	1	12,98
MV2043	89	3" 1/2	1	12,98
MV2044	92	3" 5/8	1	12,98
MV2045	95	3" 3/4	1	12,98
MV2046	98	3" 7/8	1	12,98
MV2047	102	4"	1	15,87
MV2048	105	4" 1/8	1	15,87
MV2049	108	4" 1/4	1	18,44
MV2050	111	4" 3/8	1	19,47
MV2051	114	4" 1/2	1	19,47
MV2052	121	4" 3/4	1	24,48
MV2053	127	5"	1	25,58
MV2054	140	5" 1/2	1	28,75
MV2055	152	6"	1	31,41
MV2056	160	6" 5/16	1	36,56
MV2057	210	8" 9/32	1	47,61



Para trabalhar inox, reduzir a rotação em 50%



Expositor de serras craneanas em acrílico

Composição: 32 unidades Código: MV2500

1 serra de cada:

∅ 16, 19, 22, 25, 29, 32, 38, 41, 43, 44, 48, 51, 54, 57, 60, 65, 67, 70, 76, 89, 92, 95, 102, 105, 114

2 brocas guia 6,35: 1x comp. 75mm; 1x comp. 104mm
5 adaptadores: 1xGBM 32 a 250; 2xGBP 14 a 30; 2xGBS 32 a 250

Oferta do expositor 276,00 €

Jogo para canalizadores



Composição: 8 unids
Código: MV2501
Ref: CV6C

1 serra de cada:
Ø 19, 22, 29,
38, 44, 57

1 Adaptador GBP
1 Adaptador GBS

48,85 €

Jogo para instaladores



Composição: 11 unids
Código: MV2502
Ref: CV9-I

1 serra de cada:
Ø 19, 22, 29, 35,
38, 44, 51, 57, 64

1 Adaptador GBP
1 Adaptador GBS

77,96 €

Jogo para electricistas



Composição: 8 unids
Código: MV2503
Ref: CV6E

1 serra de cada:
Ø 22, 29, 35,
44, 51, 64

1 Adaptador GBP
1 Adaptador GBS

58,47 €

Jogo industrial



Composição: 13 unids
Código: MV2504
Ref: CV11-I

1 serra de cada:
Ø 19, 22, 25, 32, 35, 38,
44, 51, 57, 64, 76

1 Adaptador GBP
1 Adaptador GBS

97,18 €



Brocas guia

Código	Ø Medida	€
MVG075	6,35mm - comprimento 75 mm	1,92
MVG110	6,35mm - comprimento 104mm	3,44



Adaptadores

Código	Tipo	Ø	€
MVA014	GBP	14 a 30	3,69
MVA032	GBM	32 a 250	5,04
MVA250	GBS	32 a 250	9,95

Código	∅ mm	∅ "	PCS	€
MV3000	14	9/16	1	7,60
MV3001	16	5/8	1	7,60
MV3002	17	11/16	1	7,60
MV3003	19	3/4	1	7,60
MV3004	20	25/32	1	7,60
MV3005	21	13/16	1	7,60
MV3006	22	7/8	1	7,60
MV3007	24	15/16	1	7,60
MV3008	25	1"	1	8,54
MV3009	27	1" 1/16	1	8,54
MV3010	29	1" 1/8	1	8,54
MV3011	30	1" 3/16	1	8,54
MV3012	32	1" 1/4	1	8,54
MV3013	33	1" 5/16	1	8,54
MV3014	35	1" 3/8	1	9,45
MV3015	37	1" 7/16	1	9,45
MV3016	38	1" 1/2	1	9,45
MV3017	40	1" 9/16	1	9,70
MV3018	41	1" 5/8	1	9,70
MV3019	43	1" 11/16	1	9,70
MV3020	44	1" 3/4	1	10,75
MV3021	45		1	10,75
MV3022	46	1" 13/16	1	10,75
MV3023	48	1" 7/8	1	10,75
MV3024	50		1	11,14
MV3025	51	2"	1	11,14
MV3026	52	2" 1/16	1	13,05
MV3027	54	2" 1/8	1	13,05
MV3028	57	2" 1/4	1	13,05
MV3029	59	2" 5/16	1	13,05
MV3030	60	2" 3/8	1	13,05
MV3031	64	2" 1/2	1	14,07
MV3032	65	2" 3/16	1	14,07
MV3033	67	2" 5/8	1	14,34
MV3034	68	2" 11/16	1	14,34
MV3035	70	2" 3/4	1	14,34
MV3036	73	2" 7/8	1	14,34
MV3037	75		1	14,91
MV3038	76	3"	1	14,91
MV3039	79	3" 1/8	1	15,23
MV3040	83	3" 1/4	1	15,90
MV3041	86	3" 3/8	1	15,90
MV3042	89	3" 1/2	1	15,90
MV3043	92	3" 5/8	1	17,89
MV3044	95	3" 3/4	1	19,48
MV3045	98	3" 7/8	1	19,62
MV3046	100		1	19,62
MV3047	102	4"	1	19,97
MV3048	105	4" 1/8	1	23,86
MV3049	108	4" 1/4	1	27,35
MV3050	111	4" 3/8	1	32,30
MV3051	114	4" 1/2	1	37,76
MV3052	121	4" 3/4	1	42,74
MV3053	127	5"	1	50,08
MV3054	140	5" 1/2	1	54,60
MV3055	152	6"	1	63,62



Expositor de serras craneanas em acrílico

Composição: 32 unidades	Código: MV3500
1 serra de cada:	
∅ 16, 19, 22, 25, 29, 32, 38, 41, 43, 44, 48, 51, 54, 57, 60, 65, 67, 70, 76, 89, 92, 95, 102, 105, 114	
2 brocas guia 6,35: 1x comp. 75mm; 1x comp. 104mm	
5 adaptadores: 1xGBM 32 a 250; 2xGBP 14 a 30; 2xGBS 32 a 250	
Oferta do expositor	384,80 €

Jogo para canalizadores



Composição: 9 unids
Código: MV3501

1 serra de cada:
Ø 19, 22, 29,
38, 44, 57

1 Adaptador GBP
1 Adaptador GBS
1 Acessório

81,90 €

Jogo para instaladores



Composição: 12 unids
Código: MV3502

1 serra de cada:
Ø 19, 22, 29, 35,
38, 44, 51, 57, 64

1 Adaptador GBP
1 Adaptador GBS
1 Acessório

131,04 €

Jogo para electricistas



Composição: 9 unids
Código: MV3503

1 serra de cada:
Ø 22, 29, 35,
44, 51, 64

1 Adaptador GBP
1 Adaptador GBS
1 Acessório

102,65 €

Jogo industrial



Composição: 13 unids
Código: MV3504

1 serra de cada:
Ø 19, 22, 25, 30, 35, 40,
51, 60, 64, 76, 83

1 Adaptador GBP
1 Adaptador GBS

163,88 €

Brocas guia



Código	Ø Medida	€
MVG075	6,35mm - comprimento 75 mm	1,92
MVG110	6,35mm - comprimento 104mm	3,44

Adaptadores



Código	Tipo	Ø	€
MVA014	GBP	14 a 30	3,69
MVA032	GBM	32 a 250	5,04
MVA250	GBS	32 a 250	9,95



Serras circulares HSS					HSS Vapo		HSS-Co 5% Vapo		HSS TIN	
∅	Esp.	Furo	Nºdentes	PCS	Código	€	Código	€	Código	€
200	1,8	32	160	1	MX4000	44,00			MX4400	62,45
225	1,9	32	180	1	MX4001	48,25	MX4200	67,08	MX4401	69,45
250	1,6	32	200	1	MX4002	52,84	MX4201	72,27	MX4402	98,18
250	2,0	32	200	1	MX4003	55,67	MX4202	74,53	MX4403	76,65
250	2,0	40	200	1	MX4004	55,67	MX4203	74,53	MX4404	76,65
250	2,5	32	200	1	MX4005	63,20	MX4204	83,40	MX4405	82,90
250	2,5	40	200	1	MX4006	63,20	MX4205	83,40	MX4406	82,90
275	2,0	32	220	1	MX4007	64,27	MX4206	96,41	MX4407	126,15
275	2,0	40	220	1	MX4008	64,27	MX4207	96,41	MX4408	126,15
275	2,5	32	220	1	MX4009	68,13	MX4208	98,03	MX4409	97,10
275	2,5	40	220	1	MX4010	68,13	MX4209	98,03	MX4410	97,10
300	2,0	32	220	1	MX4011	74,27	MX4210	116,12	MX4411	151,77
300	2,0	40	220	1	MX4012	74,27	MX4211	116,12	MX4412	151,77
300	2,5	32	220	1	MX4013	82,33	MX4212	118,08	MX4413	118,68
300	2,5	40	220	1	MX4014	82,33	MX4213	118,08	MX4414	118,68
315	2,0	32	220	1	MX4015	94,27	MX4214	129,12	MX4415	164,84
315	2,0	40	220	1	MX4016	94,27	MX4215	129,12	MX4416	164,84
315	2,5	32	220	1	MX4017	95,10	MX4216	131,25	MX4417	132,85
315	2,5	40	220	1	MX4018	95,10	MX4217	131,25	MX4418	132,85
350	2,5	32	280	1	MX4019	130,55	MX4218	153,48	MX4419	158,98
350	2,5	40	280	1	MX4020	130,55	MX4219	153,48	MX4420	158,98
350	2,5	50	280	1	MX4021	130,55	MX4220	153,48	MX4421	158,98
350	3,0	32	280	1	MX4022	135,20	MX4221	169,42	MX4422	207,84
350	3,0	40	280	1	MX4023	135,20	MX4222	169,42	MX4423	207,84
350	3,0	50	280	1	MX4024	135,20	MX4223	169,42	MX4424	207,84
370	3,0	32	280	1	MX4025	177,50	MX4224	226,40	MX4425	221,43
370	3,0	40	280	1	MX4026	177,50	MX4225	226,40	MX4426	221,43
370	3,0	50	280	1	MX4027	177,50	MX4226	226,40	MX4427	221,43
400	3,0	32	310	1	MX4028	190,20	MX4227	254,50	MX4428	247,00
400	3,0	40	310	1	MX4029	190,20	MX4228	254,50	MX4429	247,00
400	3,0	50	310	1	MX4030	190,20	MX4229	254,50	MX4430	247,00
450	3,5	40/50	350	1	MX4032	234,04	MX4230	392,84	MX4431	411,60

Alguns tipos de dentado

NB: Alteração dos dentes tem um acréscimo de 10% do valor * Outros diâmetros sob consulta

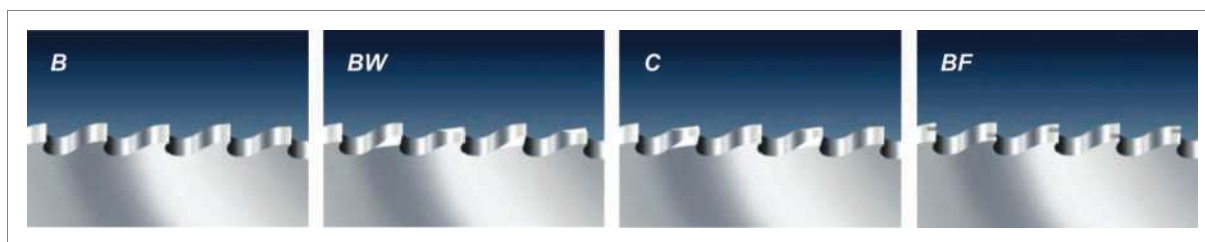



Serras circulares - PVD					TIALN - PVD INOX		PVD - STEEL		TICN - PVD	
Ø	Esp.	Furo	Nºdentes	PCS 	Código	€	Código	€	Código	€
250	1,6	32	200	1	MX8000	111,26	MX8200	91,22	MX8400	88,43
250	2,0	32	200	1	MX8001	113,22	MX8201	92,93	MX8401	90,14
250	2,0	40	200	1	MX8002	113,22	MX8202	92,93	MX8402	90,14
250	2,5	32	200	1	MX8003	121,33	MX8203	99,98	MX8403	97,19
250	2,5	40	200	1	MX8004	121,33	MX8204	99,98	MX8404	97,19
275	2,0	32	220	1	MX8005	129,60	MX8205	106,48	MX8405	103,48
275	2,0	40	220	1	MX8006	129,60	MX8206	106,48	MX8406	103,48
275	2,5	32	220	1	MX8007	142,41	MX8207	116,95	MX8407	113,72
275	2,5	40	220	1	MX8008	142,41	MX8208	116,95	MX8408	113,72
300	2,0	32	220	1	MX8009	166,19	MX8209	136,81	MX8409	133,14
300	2,0	40	220	1	MX8010	166,19	MX8210	136,81	MX8410	133,14
300	2,5	32	220	1	MX8011	167,61	MX8211	138,05	MX8411	134,39
300	2,5	40	220	1	MX8012	167,61	MX8212	138,05	MX8412	134,39
315	2,0	32	220	1	MX8013	181,40	MX8213	149,91	MX8413	146,03
315	2,0	40	220	1	MX8014	181,40	MX8214	149,91	MX8414	146,03
315	2,5	32	220	1	MX8015	182,83	MX8215	151,15	MX8415	147,27
315	2,5	40	220	1	MX8016	182,83	MX8216	151,15	MX8416	147,27
350	2,5	32	280	1	MX8017	216,09	MX8217	177,95	MX8417	173,57
350	2,5	40	280	1	MX8018	216,09	MX8218	177,95	MX8418	173,57
350	2,5	50	280	1	MX8019	216,09	MX8219	177,95	MX8419	173,57
350	3,0	32	280	1	MX8020	225,82	MX8220	186,65	MX8420	182,37
350	3,0	40	280	1	MX8021	225,82	MX8221	186,65	MX8421	182,37
350	3,0	50	280	1	MX8022	225,82	MX8222	186,65	MX8422	182,37
370	3,0	32	280	1	MX8023	293,48	MX8223	243,97	MX8423	239,00
370	3,0	40	280	1	MX8024	293,48	MX8224	243,97	MX8424	239,00
370	3,0	50	280	1	MX8025	293,48	MX8225	243,97	MX8425	239,00
400	3,0	32	310	1	MX8026	333,64	MX8226	277,67	MX8426	271,43
400	3,0	40	310	1	MX8027	333,64	MX8227	277,67	MX8427	271,43
400	3,0	50	310	1	MX8028	333,64	MX8228	277,67	MX8428	271,43

<p>Método PVD:</p> <ul style="list-style-type: none"> - Aumenta a dureza superficial - Diminui o atrito - Limita a corrosão e oxidação - Reduz o tempo de trabalho 	<ul style="list-style-type: none"> * Para materiais extra duros e aços inoxidáveis * Para condições difíceis de corte a alta velocidade * Velocidade de corte em mais de 10% a 25% que a serra normal vaporizada * Redução do tempo de corte na mesma proporção 10% a 25%. 	<ul style="list-style-type: none"> * Serras para corte de alta produção em materiais férricos (ST-37, ST-44, ST-52) * Excelentes resultados em máquinas automáticas e cortes muito rápidos 	<ul style="list-style-type: none"> * Serras para corte de alta produção em materiais inoxidáveis de difícil mecanização (AISI-304, AISI306) * Excelentes resultados em máquinas automáticas e cortes muito rápidos, económicos e com excelente acabamento
---	--	--	---

Alguns tipos de dentado

NB: Alteração dos dentes tem um acréscimo de 10% do valor * Outros diâmetros sob consulta

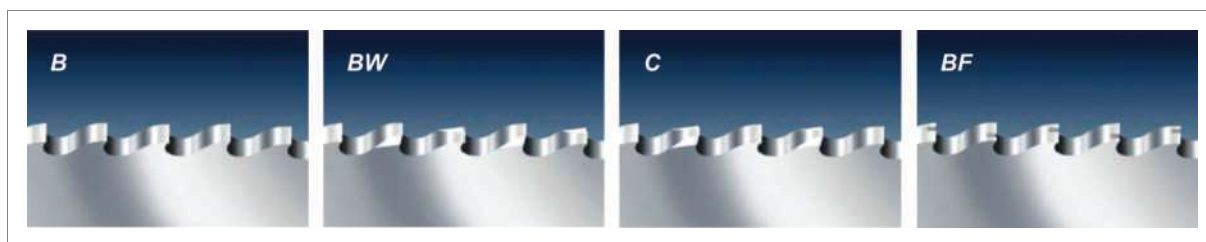

Código	∅	Esp.	Furo	Dent.	PCS	€
SE0002	20	0,25	5	64	1	10,34
SE0003	20	0,30	5	64	1	9,28
SE0004	20	0,40	5	64	1	9,28
SE0005	20	0,50	5	48	1	8,93
SE0006	20	0,60	5	48	1	8,93
SE0007	20	0,80	5	48	1	8,93
SE0008	20	1,00	5	40	1	8,93
SE0009	20	1,20	5	40	1	10,34
SE0017	20	1,50	5	40	1	11,27
SE0010	20	1,60	5	40	1	11,27
SE0011	20	2,00	5	32	1	11,79
SE0012	20	2,50	5	32	1	12,54
SE0013	20	3,00	5	32	1	13,57
SE0014	20	4,00	5	24	1	15,59
SE0015	20	5,00	5	24	1	18,35
SE0016	20	6,00	5	24	1	20,91
SE0050	25	0,20	8	80	1	10,53
SE0051	25	0,25	8	80	1	10,53
SE0052	25	0,30	8	80	1	9,85
SE0053	25	0,40	8	64	1	9,85
SE0054	25	0,50	8	64	1	9,41
SE0055	25	0,60	8	64	1	9,41
SE0056	25	0,80	8	48	1	9,41
SE0057	25	1,00	8	48	1	9,41
SE0058	25	1,20	8	48	1	10,77
SE0066	25	1,50	8	48	1	11,52
SE0059	25	1,60	8	48	1	11,52
SE0060	25	2,00	8	40	1	12,56
SE0061	25	2,50	8	40	1	13,29
SE0062	25	3,00	8	32	1	14,55
SE0063	25	4,00	8	32	1	17,31
SE0064	25	5,00	8	32	1	20,03
SE0065	25	6,00	8	24	1	22,61
SE0100	32	0,20	8	100	1	11,27
SE0101	32	0,25	8	100	1	11,27
SE0102	32	0,30	8	80	1	10,34
SE0103	32	0,40	8	80	1	10,34
SE0104	32	0,50	8	80	1	9,85
SE0105	32	0,60	8	64	1	9,85
SE0106	32	0,80	8	64	1	9,85
SE0107	32	1,00	8	64	1	9,85
SE0108	32	1,20	8	48	1	11,52
SE0116	32	1,50	8	48	1	12,09
SE0109	32	1,60	8	48	1	12,09
SE0110	32	2,00	8	48	1	13,07
SE0111	32	2,50	8	40	1	14,07
SE0112	32	3,00	8	40	1	15,05
SE0113	32	4,00	8	40	1	19,10
SE0114	32	5,00	8	32	1	21,53
SE0115	32	6,00	8	32	1	23,58
SE0150	40	0,20	10	128	1	12,26
SE0151	40	0,25	10	100	1	12,26
SE0152	40	0,30	10	100	1	11,79
SE0153	40	0,40	10	100	1	11,79
SE0154	40	0,50	10	80	1	11,09
SE0155	40	0,60	10	80	1	11,09
SE0156	40	0,80	10	80	1	11,09
SE0157	40	1,00	10	64	1	11,09

Código	∅	Esp.	Furo	Dent.	PCS	€
SE0158	40	1,20	10	64	1	11,79
SE0166	40	1,50	10	64	1	12,54
SE0159	40	1,60	10	64	1	12,54
SE0160	40	2,00	10	48	1	13,57
SE0161	40	2,50	10	48	1	15,05
SE0162	40	3,00	10	48	1	17,31
SE0163	40	4,00	10	40	1	20,54
SE0164	40	5,00	10	40	1	25,55
SE0165	40	6,00	10	40	1	28,09
SE0200	50	0,20	13	128	1	14,55
SE0201	50	0,25	13	128	1	14,55
SE0202	50	0,30	13	128	1	13,29
SE0203	50	0,40	13	100	1	13,29
SE0204	50	0,50	13	100	1	12,54
SE0205	50	0,60	13	100	1	12,54
SE0207	50	0,80	13	80	1	12,54
SE0208	50	1,00	13	80	1	12,54
SE0209	50	1,20	13	80	1	13,29
SE0210	50	1,50	13	64	1	14,55
SE0211	50	1,60	13	64	1	14,55
SE0212	50	2,00	13	64	1	15,59
SE0213	50	2,50	13	64	1	16,80
SE0214	50	3,00	13	48	1	19,10
SE0216	50	4,00	13	48	1	22,03
SE0217	50	5,00	13	48	1	29,11
SE0218	50	6,00	13	40	1	33,04
SE0250	63	0,25	16	160	1	15,33
SE0251	63	0,30	16	128	1	15,05
SE0252	63	0,40	16	128	1	15,05
SE0253	63	0,50	16	128	1	14,55
SE0254	63	0,60	16	100	1	14,55
SE0256	63	0,80	16	100	1	14,55
SE0257	63	1,00	16	100	1	14,55
SE0258	63	1,20	16	80	1	15,05
SE0259	63	1,50	16	80	1	16,80
SE0260	63	1,60	16	80	1	16,80
SE0261	63	2,00	16	80	1	17,99
SE0262	63	2,50	16	64	1	19,10
SE0263	63	3,00	16	64	1	21,08
SE0265	63	4,00	16	64	1	26,55
SE0266	63	5,00	16	48	1	33,61
SE0267	63	6,00	16	48	1	37,64
SE0300	80	0,30	22	160	1	17,81
SE0301	80	0,40	22	160	1	17,81
SE0302	80	0,50	22	128	1	17,31
SE0303	80	0,60	22	128	1	17,31
SE0305	80	0,80	22	128	1	17,31
SE0306	80	1,00	22	100	1	17,31
SE0307	80	1,20	22	100	1	17,81
SE0308	80	1,50	22	100	1	18,82
SE0309	80	1,60	22	100	1	18,82
SE0310	80	2,00	22	80	1	20,91
SE0311	80	2,50	22	80	1	24,79
SE0312	80	3,00	22	80	1	27,09
SE0314	80	4,00	22	64	1	33,08
SE0315	80	5,00	22	64	1	40,62
SE0316	80	6,00	22	64	1	45,62

Código	∅	Esp.	Furo	Dent.	PCS	€
SE0350	100	0,50	22	160	1	20,03
SE0351	100	0,60	22	160	1	20,03
SE0352	100	0,80	22	128	1	20,03
SE0353	100	1,00	22	128	1	20,03
SE0354	100	1,20	22	128	1	20,91
SE0355	100	1,50	22	100	1	25,07
SE0356	100	1,60	22	100	1	25,07
SE0357	100	2,00	22	100	1	27,55
SE0358	100	2,50	22	100	1	31,09
SE0359	100	3,00	22	80	1	33,61
SE0361	100	4,00	22	80	1	45,62
SE0362	100	5,00	22	80	1	51,15
SE0363	100	6,00	22	64	1	59,68
SE0400	125	0,60	22	160	1	30,60
SE0401	125	0,80	22	160	1	30,60
SE0402	125	1,00	22	160	1	30,60
SE0403	125	1,20	22	128	1	30,60
SE0404	125	1,50	22	128	1	32,12
SE0405	125	1,60	22	128	1	30,60
SE0406	125	2,00	22	128	1	33,61
SE0407	125	2,50	22	100	1	35,55
SE0408	125	3,00	22	100	1	39,63
SE0409	125	4,00	22	100	1	59,12
SE0410	125	5,00	22	80	1	69,16
SE0411	125	6,00	22	80	1	77,19
SE0450	160	1,00	32	160	1	43,10
SE0451	160	1,20	32	160	1	43,10
SE0452	160	1,50	32	160	1	44,10
SE0453	160	1,60	32	160	1	44,10
SE0454	160	2,00	32	128	1	45,62
SE0455	160	2,50	32	128	1	51,15
SE0456	160	3,00	32	128	1	58,12
SE0457	160	4,00	32	100	1	81,74
SE0458	160	5,00	32	100	1	96,72
SE0459	160	6,00	32	100	1	110,25
SE0500	200	1,00	32	200	1	57,06
SE0501	200	1,20	32	200	1	57,06
SE0502	200	1,50	32	160	1	61,46
SE0503	200	1,60	32	160	1	61,46
SE0504	200	2,00	32	160	1	50,41
SE0505	200	2,50	32	160	1	73,91
SE0506	200	3,00	32	128	1	82,64
SE0508	200	4,00	32	128	1	116,95
SE0509	200	5,00	32	128	1	139,17
SE0510	200	6,00	32	100	1	160,40



DIN1837 - FORMA DO DENTE TIPO A



Serras circulares de segmentos em HSS

∅	Esp.	Furo	Nº Seg.	PCS	€
250	4,00	32	12	1	255,82
275	4,00	40	12	1	260,36
315	4,00	40	16	1	322,99
355	4,50	40	16	1	351,02
370	3,50	50	16	1	373,55
400	4,00	50	16	1	406,00
460	4,50	60	18	1	506,62
510	5,50	60	18	1	572,15
560	5,50	70	18	1	599,92
610	6,00	80	20	1	703,96
630	6,00	80	20	1	706,98
660	6,00	80	20	1	819,16
710	6,00	80	24	1	875,82
760	6,00	80	24	1	1.021,25
800	7,00	80	24	1	1.096,91
910	7,00	80	30	1	1.457,16
1010	8,00	100	30	1	1.758,53
1110	8,00	100	36	1	2.056,54
1210	8,00	100	36	1	2.459,06
1250	9,00	100	36	1	2.743,92
1310	9,00	100	36	1	2.936,79
1400	9,00	100	36	1	3.280,10
1510	10,00	100	36	1	5.011,97
1600	11,00	150	40	1	6.097,37

Segmentos

€
27,40
28,49
27,12
27,25
29,16
27,25
30,07
31,69
33,14
34,16
34,27
37,11
36,40
38,29
41,42
47,70
47,70
47,70
55,86
57,75
61,52
63,49
71,26
70,00

Número de dentes a indicar: Z2 - Z3 - Z4 - Z5 - Z6 - Z8 - Z10 - Z12

Prestamos assistência técnica

Alumínio

Código	∅	Esp.	Furo	Nº dentes	PCS	€
MZP100	250	3,20	32	60 DP	1	62,24
MZP114	250	3,20	30	60 DP	1	62,24
MZP101	250	3,20	32	80 DP	1	73,72
MZP112	250	3,20	32	80 DN	1	73,72
MZP115	250	3,20	30	80 DP	1	73,72
MZP102	300	3,30	32	72 DP	1	74,26
MZP116	300	3,30	30	72 DP	1	74,26
MZP103	300	3,30	32	96 DP	1	88,72
MZP119	300	3,30	32	96 DN	1	88,72
MZP113	300	3,30	30	96 DP	1	88,72
MZP105	350	3,40	32	84 DP	1	88,72
MZP106	350	3,40	32	108 DP	1	101,29
MZP120	350	3,40	32	108 DN	1	101,29
MZP117	350	3,40	30	108 DP	1	101,29
MZP107	400	3,60	32	120 DP	1	121,48
MZP110	400	3,60	30	120 DP	1	121,48
MZP123	400	3,60	30	120 DN	1	121,48
MZP130	450	3,80	32	96 DP	1	152,61
MZP108	450	3,80	32	128 DP	1	163,26
MZP111	450	3,80	30	128 DP	1	163,26
MZP109	500	4,20	32	140 DP	1	211,58
MZP118	500	4,20	30	140 DP	1	211,58
MZP175	550	4,20	30	168 DP	1	374,02
MZP174	600	4,20	32	160 DP	1	713,15



Madeira

Código	∅	Esp.	Furo	Nº dentes	PCS	€
MZP150	200	3,20	30	32 DA	1	39,04
MZP152	250	3,20	30	40 DA	1	48,88
MZP153	250	3,20	30	60 DA	1	55,56
MZP154	250	3,20	30	80 DA	1	66,88
MZP155	300	3,20	30	48 DA	1	56,16
MZP156	300	3,20	30	72 DA	1	67,00
MZP157	300	3,20	30	96 DA	1	77,80
MZP158	350	3,60	30	54 DA	1	69,16
MZP170	400	3,60	30	64 DA	1	79,80
MZP171	450	3,80	30	72 DA	1	133,22
MZP172	500	4,20	30	80 DA	1	162,24



Laminados (DP dente trapezoidal)

Código	∅	Esp.	Furo	Nº dentes	PCS	€
MZP159	250	3,20	30	60 DT	1	60,01
MZP160	250	3,20	30	80 DT	1	67,64
MZP161	300	3,20	30	72 DT	1	72,35
MZP162	300	3,20	30	96 DT	1	80,01



DT - Dente trapezoidal

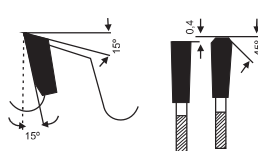

DA - Dente Alternado

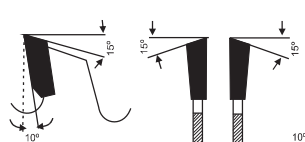

DN - Dente Negativo

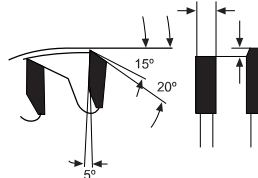

DP - Dente Positivo

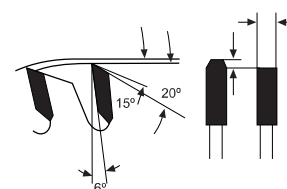

Prestamos assistência técnica



Multiusos (corte a seco)

Código	∅	Esp.	Furo	Nº dentes	Vel. R.P.M.	PCS	€
MZSP260	180	2,20	20	32	2500	1	49,41
MZSP295	180	2,20	30	32	2500	1	49,41
MZSP265	230	2,20	20	40	2200	1	58,15
MZSP294	230	2,20	30	40	2200	1	58,15
MZSP270	250	2,40	20	48	2200	1	73,32
MZSP275	300	2,40	25,4	60	1600	1	101,51
MZSP291	300	2,40	30	60	1600	1	101,51
MZSP280	300	2,40	25,4	80	1600	1	118,44
MZSP292	300	2,40	30	80	1600	1	118,44
MZSP285	350	2,50	30	70	1200	1	140,99
MZSP290	350	2,50	30	90	1200	1	169,20
MZSP293	350	2,50	25,4	90	1200	1	169,20

Aplicação:

Metais: aço, ferro, chapa, latão, alumínio e cobre
 Madeira: dura, macia, painéis, material isolante mesas com parafusos metálicos, pregos e revestidas
 Plásticos: macio ou duro, fibra de vidro

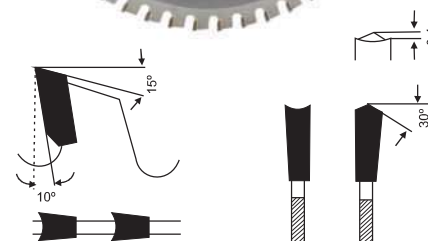

Para máquinas portáteis

Código	∅	Esp.	Furo	Nº dentes	PCS	€
MZSP200	160	2,50	16	24	1	30,62
MZSP205	160	2,50	16	48	1	38,14
MZSP212	180	2,50	30	24	1	27,82
MZSP213	180	2,50	30	40	1	34,58
MZSP215	190	2,50	30	24	1	37,96
MZSP220	190	2,50	30	40	1	44,04
MZSP225	210	2,80	30	24	1	35,88
MZSP230	210	2,80	30	48	1	43,94
MZSP235	230	2,80	30	24	1	34,40
MZSP240	230	2,80	30	34	1	35,98
MZSP245	230	2,80	30	48	1	44,46
MZSP246	235	2,80	30	24	1	40,96
MZSP247	235	2,80	30	48	1	41,79
MZSP250	Anilhas de redução 16 / 20				1	2,60
MZSP251	Anilhas de redução 25 / 30					2,60
MZSP252	Anilhas de redução 25,4 / 30					2,60

Utilização para máquinas:

AEG - BLACK-DECKER - BOSH - HITACHI - KRESS - METABO - ELU - SKIL - FESTO
 DEWALT - MAKITA - HAFNER - ELEKTRA - FEIN - RIOBY - PEUGEOT - HOLZ - MAFELL



Prestamos assistência técnica

PROF-MULTIUSOS M42
HSSE 8% Co

* Para corte de perfis, tubos, maciços e todo o tipo de materiais em geral



Dimensão Altura x Espessura	Nº dentes p/polegada						Preço € p/metro	
	2/3	3/4	4/6	5/8	6/10	8/12		10/14
13 x 0,65					S	S	S	14,66
20 x 0,90			K	S	S	S	S	14,66
27 x 0,90			K	K	S	S	S	15,48
34 x 1,10	K	K	K	S	S	S		17,65
41 x 1,30	K	K	K					23,30

Forma do dente: (S) 0° (K) Positivo

**NOVO
ARTIGO**
PROF-MULTIUSOS SUPER M42
HSSE 8% Co

* Para corte individuais e em série de perfis e material maciço
 * Para corte coletivo ou em camadas

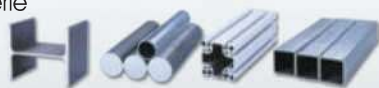

Dimensão Altura x Espessura	Nº dentes p/polegada						Preço € p/metro
	3/4	4/6	5/8	6/10	8/12	10/14	
13 x 0,65				S	S	S	16,14
20 x 0,90		S	S	S	S	S	16,14
27 x 0,90	S	S	S	S	S	S	16,76
34 x 1,10	S	S	S	S	S	S	19,10
41 x 1,30	S	S	S	S			25,47
54 x 1,30				S			35,35

Forma do dente: (S) 0°

PROF-PERFIL M42
HSSE 8% Co

* Para corte de perfis e vigas
 * Geometria do dente extra estável contra a quebra de dentes
 * Grande redução de vibrações

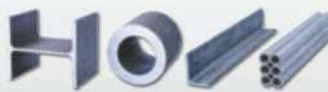

Dimensão Altura x Espessura	Nº dentes p/polegada						Preço € p/metro
	2/3	3/4	4/6	5/7	8/11	12/16	
20 x 0,90				P	P	P	16,14
27 x 0,90		P	P	P	P	P	16,76
34 x 1,10	P	P	P	P	P		19,10
41 x 1,30	P	P		P	P		25,47
54 x 1,60	P	P		P			39,28

Forma do dente: (P) Positivo



Prestamos assistência técnica



PROF-MACIÇOS M42

HSSE 8% Co

- * Para perfis e material maciço
- * Para corte coletivo ou em camadas



Dimensão Altura x Espessura	0,75/1,25	Nº dentes p/polegada					Preço € p/metro
		1,4/2	2/3	3/4	4/6	5/8	
27 x 0,90			K	K	K	K	17,30
34 x 1,10			K	K	K	K	19,77
41 x 1,30			K	K	K	K	25,99
54 x 1,60			K	K	K	K	40,53
67 x 1,60	K	K	K	K	K		60,51
80 x 1,60	K	K	K	K			90,22

Forma do dente: (K) Positivo



PROF-INOX X-3000 M51

HSSE 10% Co

- * Para perfis e material maciço
- * Para corte coletivo ou em camadas
- * Para trabalhos difíceis de maquinação



Dimensão Altura x Espessura	Nº dentes p/polegada					Preço € p/metro
	1,4/2	2/3	3/4	4/6	5/8	
27 x 0,90			K	K	K	20,95
34 x 1,10		K	K	K		23,69
41 x 1,30		K	K	K		34,71
54 x 1,60	K	K	K	K		47,00
67 x 1,60	K	K	K			73,76

Forma do dente: (K) Positivo



PROF TCT/FUT

DENTES EM METAL DURO

- * Para materiais abrasivos, minerais, grafite e ferro fundido cinzento.



Dimensão Altura x Espessura	0,85/1,15	Nº dentes p/polegada				Preço € p/metro
		1/1,4	1,4/2	2/3	3/4	
20 x 0,80					T	s/consulta
27 x 0,90					T	s/consulta
34 x 1,10					T	s/consulta
41 x 1,30			T	T	T	s/consulta
54 x 1,60	T	T	T	T		s/consulta
67 x 1,60	T	T	T	T		s/consulta
80 x 1,60	T	T	T			s/consulta

Forma do dente: (T) Positivo



Prestamos assistência técnica

Perfis, tubos e vigas

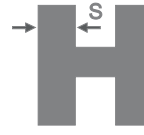
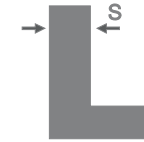
0mm - 1mm	12/16z 10/14z	
1mm - 2,5mm	8/11z 8/12z	
2,5mm - 5mm	5/7z 6/10z	
5mm - 7mm	5/7z 5/8z	
7mm - 10mm	3/4z 4/6z	
10mm - 20mm	3/4z 3/4z	
20mm - 45mm	2/3z 2/3z	

Maciços

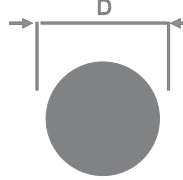
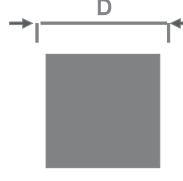
0mm - 10mm	10/14z	
10mm - 20mm	8/12z	
20mm - 40mm	6/10z	
40mm - 50mm	5/8z	
50mm - 90mm	4/6z	
90mm - 120mm	3/4z	
120mm - 150mm	2/3z	

OFERTA
EXPOSITOR E
MÓDULOS



**EXPOSITOR 1
4 MÓDULOS**

Brocas para martelo SDS "S4" super profissional

MÓDULO
1

Composição: 99 brocas		Código: MTSDSE01	
Ø	Unidades	Ø	Unidades
5 x 110	5	6 x 210	5
6 x 110	5	8 x 210	5
5 x 160	5	10 x 210	5
6 x 160	10	12 x 210	5
8 x 160	10	14 x 210	5
9 x 160	5	16 x 210	3
10 x 160	5	8 x 260	5
12 x 160	5	10 x 260	5
		12 x 260	5
		14 x 260	3
		16 x 260	3

Brocas para martelo SDS "4X4" super profissional

MÓDULO
2

Composição: 99 brocas		Código: MT4X4200	
Ø	Unidades	Ø	Unidades
5 x 110	5	8 x 210	5
6 x 110	5	10 x 210	5
7 x 110	5	12 x 210	5
8 x 110	5	14 x 210	3
10 x 110	5	10 x 260	5
6 x 160	10	12 x 260	5
8 x 160	10	14 x 260	5
10 x 160	5	12 x 310	3
12 x 160	5	14 x 310	3
14 x 160	5		

Brocas universais "Fura Tudo"

MÓDULO
3

Composição: 131 brocas		Código: MTFTJ001	
Ø	Unidades	Ø	Unidades
3 x 70	8	10 x 120	10
4 x 75	8	11 x 150	5
5 x 85	35	12 x 150	5
6 x 100	35	13 x 150	5
8 x 120	10	14 x 150	5
		16 x 150	5

Brocas para martelos SDS "MAX" - 4 cortes

MÓDULO
5

Composição: 22 brocas		Código: MBMA999	
Ø	Unidades	Ø	Unidades
12x200x340	2	22x200x320	1
14x200x340	2	24x200x320	1
16x200x340	2	25x200x320	1
16x400x540	2	28x450x570	1
18x200x340	2	30x450x570	1
18x400x540	2	38x450x570	1
20x200x320	2		
20x400x520	2		

3.218,08 €

CÓDIGO: EXPOSITOR12

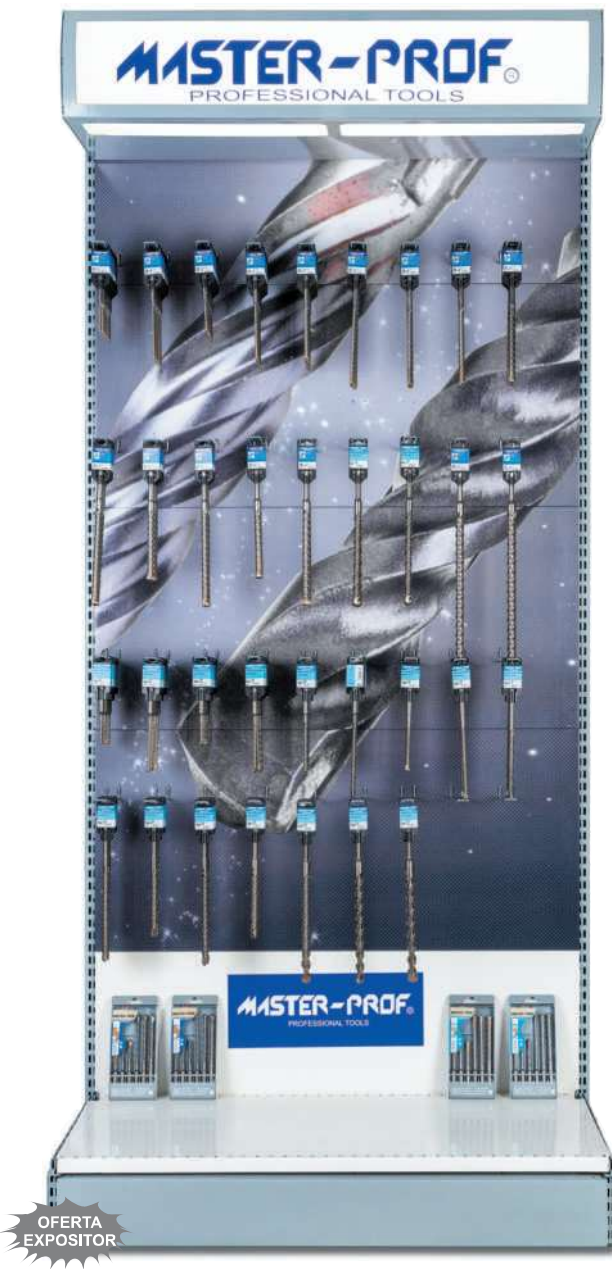

1.622,92€

CÓDIGO: EXPOSITOR09



1.717,46€

CÓDIGO: EXPOSITOR08

Unds	Medida	Descrição	Unds	Medida	Descrição
10	5 x 110	SDS S4	10	5 x 110	SDS 4X4
10	5 x 160	SDS S4	10	5 x 160	SDS 4X4
10	6 x 110	SDS S4	10	6 x 110	SDS 4X4
10	6 x 160	SDS S4	10	6 x 160	SDS 4X4
10	8 x 160	SDS S4	10	8 x 160	SDS 4X4
5	8 x 210	SDS S4	5	8 x 210	SDS 4X4
5	10 x 160	SDS S4	5	10 x 160	SDS 4X4
5	10 x 210	SDS S4	5	10 x 210	SDS 4X4
5	12 x 210	SDS S4	5	12 x 210	SDS 4X4
5	12 x 260	SDS S4	5	12 x 260	SDS 4X4
5	14 x 210	SDS S4	5	14 x 210	SDS 4X4
5	14 x 260	SDS S4	5	14 x 260	SDS 4X4
2	16 x 210	SDS S4	2	16 x 210	SDS 4X4
2	16 x 260	SDS S4	2	16 x 260	SDS 4X4
1	18 x 300	SDS S4	1	18 x 450	SDS 4X4
1	20 x 300	SDS S4	1	20 x 450	SDS 4X4
			2	Jogos SDS S4 (6 Pcs)	
			2	Jogos SDS 4X4 (6 Pcs)	

Serras craneanas bimetálicas HSS-CO 8%

unidades medidas
2 de cada 16, 19, 22, 25, 29, 32, 38, 41, 43, 44, 48, 51, 54, 57,
2 de cada 60, 65, 67, 70, 76, 89, 92, 95, 102, 105, 114

- +
- 2 brocas guia 6,35 comp. 75
 - 2 brocas guia 6,35 comp. 104mm
 - 2 adaptador GBM 32 a 250
 - 4 adaptadores GBP 14 a 30
 - 4 adaptadores GBS 32 a 250

- +
- 2 Jogos para canalizadores
 - 2 Jogos para instaladores
 - 2 Jogos para electricistas
 - 2 Jogos industriais



1.932,75€

1175 discos abrasivos
CÓDIGO: EXPOSITOR11

Código	Unidades	Medida	Tipo de disco
MD002	100	115 x 3	Corte de ferro
MD003	50	125 x 3	Corte de ferro
MD004	50	180 x 3,2	Corte de ferro
MD005	100	230 x 3,2	Corte de ferro
MD006	25	300 x 3,2	Corte de ferro
MD011	50	115 x 3	Corte de pedra
MD012	50	125 x 3	Corte de pedra
MD013	25	180 x 3	Corte de pedra
MD014	25	230 x 3	Corte de pedra
MD021	100	115 x 6	Rebarbar
MD022	50	125 x 6	Rebarbar
MD023	100	180 x 7	Rebarbar
MD025	100	230 x 6	Rebarbar
MD030	200	115 x 1	Corte de inox
MD032	50	115 x 2	Corte de inox
MD034	50	125 x 1,6	Corte de inox
MD036	25	180 x 2	Corte de inox
MD038	25	230 x 2	Corte de inox



1.718,55€

54 discos diamantados
CÓDIGO: EXPOSITOR10

Unidades	Super económico	Unidades	Banda lisa
5	MK100 115 x 2,1	5	MK184 115 x 1
5	MK103 230 x 2,6	5	MK188 230 x 1,6
Contínuo normal		Banda lisa turbo	
5	MK146 115 x 2,1	2	MK330 115 x 1,2
5	MK149 230 x 2,6	2	MK335 230 x 1,6
Turbo ondulado		Laser asfalto	
5	MK162 115 x 2,1	2	MK196 300 x 2,8
5	MK165 230 x 2,6	2	MK197 350 x 2,8
		2	MK198 400 x 3
Ultra super turbo			
2	MK340 115 x 2,6		
2	MK344 230 x 3,1		

MÓDULO 1

Brocas para martelo SDS "S4" super profissional



Composição: 99 brocas
Código: MTSDE01

Ø	Unidades
5 x 110	5
6 x 110	5
5 x 160	5
6 x 160	10
8 x 160	10
9 x 160	5
10 x 160	5
12 x 160	5
6 x 210	5
8 x 210	5
10 x 210	5
12 x 210	5
14 x 210	5
16 x 210	3
8 x 260	5
10 x 260	5
12 x 260	5
14 x 260	3
16 x 260	3

615,62 €

OFERTA MÓDULO

MÓDULO 2

Brocas para martelo SDS "4X4" super profissional



Composição: 99 brocas
Código: MT4X4200

Ø	Unidades
5 x 110	5
6 x 110	5
7 x 110	5
8 x 110	5
10 x 110	5
6 x 160	10
8 x 160	10
10 x 160	5
12 x 160	5
14 x 160	5
8 x 210	5
10 x 210	5
12 x 210	5
14 x 210	3
10 x 260	5
12 x 260	5
14 x 260	5
12 x 310	3
14 x 310	3

968,92 €

OFERTA MÓDULO

MÓDULO 3

Brocas universais "Fura Tudo"



Composição: 131 brocas
Código: MIFTJ001

Ø	Unidades
3 x 70	8
4 x 75	8
5 x 85	35
6 x 100	35
8 x 120	10
10 x 120	10
11 x 150	5
12 x 150	5
13 x 150	5
14 x 150	5
16 x 150	5

361,42 €

OFERTA MÓDULO

MÓDULO 4

Brocas p/pedra "Standard" qualidade extra



Composição: 226 brocas
Código: MNJ001

Ø	L mm	Unidades
3 x 60		7
4 x 75		7
5 x 85		50
6 x 120		50
8 x 120		50
10 x 120		20
12 x 150		12
14 x 150		4
8 x 300		5
10 x 300		5
12 x 300		5
16 x 400		3
18 x 400		3
20 x 400		3
25 x 400		2

323,49 €

OFERTA MÓDULO

MÓDULO 5

Brocas para martelos SDS "MAX"



Composição: 22 brocas
Código: MBMA999

Ø	Unidades
12 x 200 x 340	2
14 x 200 x 340	2
16 x 200 x 340	2
16 x 400 x 540	2
18 x 200 x 340	2
18 x 400 x 540	2
20 x 200 x 320	2
20 x 400 x 520	2
22 x 200 x 320	1
24 x 200 x 320	1
25 x 200 x 320	1
28 x 450 x 570	1
30 x 450 x 570	1
38 x 450 x 570	1

1279,71 €

MÓDULO 7

Fresas perfuradoras HSS



Composição: 33 fresas
Código: MFJHSS001

Ø	Unds	Ø	Unds
18	2	29	1
19	2	30	1
20	2	31	1
21	2	32	1
22	2	33	1
23	2	34	1
24	2	35	1
25	2	36	1
26	2	37	1
27	2	38	1
28	2	39	1

538,64 €

OFERTA MÓDULO

MÓDULO 8

Fresas perfuradoras TCT para inox



OFERTA MÓDULO

Composição: 18 fresas
Código: MFCTJ001

Ø	Unidades
18	1
19	1
20	1
21	1
22	1
23	1
24	1
25	1
26	1
27	1
28	1
29	1
30	1
31	1
32	1
35	1
38	1
40	1

748,28 €

MÓDULO 9

Brocas cilíndricas rectificadas Speedmaster



OFERTA MÓDULO

Composição: 366 unidades
Código: MTSPEEDJ001

Ø	Unds	Ø	Unds
1,00	10	5,50	10
1,50	10	6,00	10
2,00	10	6,50	10
2,50	10	7,00	10
3,00	50	7,50	10
3,25	10	8,00	10
3,50	10	8,50	5
3,75	10	9,00	5
4,00	50	9,50	5
4,25	10	10,00	5
4,50	10	10,50	5
4,75	10	11,00	5
5,00	10	12,00	5
		13,00	5

1 Jogo de 1 a 10
1 Jogo de 1 a 13

980,47 €

MÓDULO 12

Jogos de machos rosca métrica em HSS



OFERTA MÓDULO

Composição: 96 jogos
Código: MMHSSJ001

Ø	Unidades
M 3 x 0,5	10
M 4 x 0,7	10
M 5 x 0,8	20
M 6 x 1	20
M 8 x 1,25	10
M 10 x 1,5	10
M 12 x 1,75	5
M 14 x 2	5
M 16 x 2	2
M 18 x 2,5	2
M 20 x 2,5	2

1.161,21 €

MÓDULO 15

Serras cranecanas HSS-CO 8% para inox



OFERTA MÓDULO

Composição: 56 unidades
Código: MV3510

Ø	Unds	Ø	Unds
16	2	57	2
19	2	60	2
22	2	65	2
25	2	67	2
29	2	70	2
32	2	76	2
38	2	89	2
41	2	92	2
43	2	95	2
44	2	102	2
48	2	105	2
51	2	114	2
54	2		

1 adapt. GBM de 32 a 250
1 adapt. GBP de 14 a 30
2 adapt. GBS de 32 a 250
2 brocas guias 6,35
(1x 75mm e 1x 104mm)

688,30 €

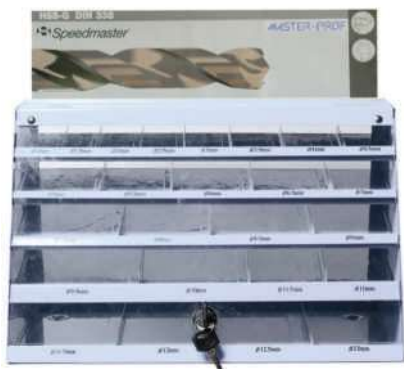

Expositor em chapa p/brocas
H - 23,5 cm * L - 37,5 cm * P - 20,5 cm

Código: MVAZIO1000

52,00 €
PREÇO LÍQUIDO



Expositor em acrílico p/brocas
H - 41 cm * L - 38 cm * P - 21 cm

Código: MVAZIO2000

125,00 €
PREÇO LÍQUIDO



Vitrine em vidro
H - 52 cm * L - 44 cm * P - 31 cm

Código: MVAZIO8001

125,00 €
PREÇO LÍQUIDO



Expositor Show Off

Código: MVAZIO4000

200,00 €
PREÇO LÍQUIDO

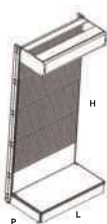

H - 227cm
L - 105 cm
P - 61,5 cm



Módulo

H - 60 cm * L - 40 cm * P - 31 cm

Código: MVAZIO5000

50,00 €
PREÇO LÍQUIDO



Módulo cesta

H - 65 cm * L - 39 cm * P - 33 cm

Código: MVAZIO6000

72,00 €
PREÇO LÍQUIDO

FICHA TÉCNICA



Tabela de selecção de brocas em função do material a trabalhar



Material a trabalhar	Qualidade da broca	Velocidade de corte mt / min	Broca diamante mm						Lubrificante
			2	5	8	12	16	25	
Aço comum	HSS	20 / 25							Óleo corte Óleo solúvel
	HSS-CO	25 / 30	0,05	0,12	0,20	0,25	0,30	0,40	
	M.D.	70 / 80							
Aço de liga	HSS	10 / 12							Óleo corte Óleo solúvel
	HSS-CO	15 / 18	0,03	0,07	0,10	0,16	0,20	0,25	
	M.D.	30 / 50							
Aço de liga AL, NI, CR	HSS	10 / 12							Óleo corte Óleo solúvel
	HSS-CO	15 / 18	0,02	0,05	0,08	0,12	0,14	0,18	
	M.D.	30 / 50							
Aço NI, CR, MO	HSS-CO 8% ponta em M. D.	8 / 10 15 / 30	0,02	0,05	0,08	0,12	0,14	0,18	Óleo corte Óleo solúvel
Aço Refractário (aço resistente à corrosão)	HSS-CO 8% ponta em M.D.	8 / 10 15 / 30	0,02	0,05	0,08	0,12	0,14	0,18	Óleo corte Óleo solúvel
Titânio	HSS-CO 8% ponta em M.D.	3 / 6 15 / 30	0,02	0,05	0,08	0,12	0,14	0,18	Óleo corte
Fundição	HSS	20 / 35							Óleo corte Seco
	HSS-CO	25 / 30	0,03	0,07	0,10	0,16	0,14	0,25	
	M.D.	40 / 60							
Bronze / Latão	HSS	20 / 35							Óleo corte Óleo solúvel
	HSS-CO	25 / 30	0,05	0,08	0,14	0,20	0,20	0,30	
	M.D.	40 / 100							
Alumínio	HSS	40 / 80	0,05	0,14	0,18	0,22	0,25	0,40	Óleo corte Óleo solúvel
Liga de alumínio	HSS	30 / 60	0,05	0,14	0,18	0,22	0,30	0,40	Óleo corte Óleo solúvel
Madeira	HSS	60 / 90	0,08	0,18	0,25	0,30	0,35	0,40	A seco
Borracha dura	HSS	40 / 80	0,08	0,18	0,25	0,30	0,35	0,40	A seco

Tabela de conversão da velocidade de corte em R. P. M. em função do diâmetro da broca

Ø	Velocidade de corte - mt / min													
	3	4	5	6	8	10	12	15	18	20	25	30	35	40
2	478	637	796	955	1274	1592	1911	2388	2864	3185	3981	4777	5570	6369
3	318	425	531	637	849	1062	1274	1592	1909	2123	2654	3150	3713	4246
4	239	318	398	478	637	796	955	1194	1432	1592	1990	2389	2785	3185
5	191	255	318	382	510	637	764	955	1145	1274	1592	1911	2228	2548
6	159	212	265	318	425	531	637	796	954	1062	1327	1592	1856	2123
8	119	159	199	239	318	398	478	597	716	796	995	1194	1392	1592
10	96	127	159	191	255	318	382	478	572	637	796	955	1114	1274
12	80	106	133	159	212	265	318	398	477	531	663	796	928	1062
14	68	91	114	136	182	227	273	341	409	455	569	682	795	910
16	60	80	100	119	159	199	239	299	358	398	498	597	696	796
18	53	71	88	106	142	170	212	265	318	354	442	531	618	708
20	48	64	80	96	127	159	191	239	286	318	398	478	557	637
22	43	57	72	86	115	144	173	216	260	289	361	433	506	578
24	39	52	66	79	106	132	159	198	238	265	331	397	464	530
27	35	47	58	70	94	117	141	176	211	235	294	353	412	471
30	32	42	53	64	85	106	127	159	190	212	265	318	371	425

HSS - TiN + 20% com refrigeração

HSS-CO TIALN + 50% a 80% a seco



N. B. Os valores fornecidos nesta tabela são orientativos

Brocas para pedra com pastilha



	Ø 3	Ø 4	Ø 5	Ø 6	Ø 8	Ø 10	Ø 12	Ø 14	Ø 16
R. P. M.	2,300	2,300	2,000	1,600	1,400	1,300	1,000	800	600
N. B. : granito e pedra dura, reduzir a velocidade de 40% para 60%									

Brocas universais "fura tudo"



Material a trabalhar	Ø 4	Ø 6	Ø 8	Ø 10	Ø 12	Ø 14	Ø 16
Pedra	2390	1590	1195	955	800	680	600
Plástico	4775	3185	2385	1910	1590	1365	1195
Aço XC (60-80Kg./mm)	1590	1060	800	640	530	455	400
Aço XC13 (90-110Kg./mm)	795	530	400	320	265	225	200
Vidro	400	285	220	170	140	125	110
Madeira dura	1590	1060	800	640	530	455	400
Madeira aglomerada	2385	1590	1195	955	795	680	595
N. B. : trabalhar só em rotação, sem martelo							

Fresas craneanas



Material a trabalhar	Ø Serra mm. R. P. M.															
	14 a 27	19 a 24	25 a 32	33 a 38	40 a 44	46 a 51	52 a 57	59 a 64	65 a 70	73 a 79	83 a 89	92 a 98	102 a 108	111 a 121	127 a 140	146 a 152
Ferro / Aço mole	550	425	300	250	210	180	160	140	130	115	100	90	80	75	60	55
Aço trat. / Aço inox	275	210	150	125	100	90	80	70	65	55	50	45	40	35	25	25
Cobre	365	280	200	165	135	120	105	95	85	75	65	60	55	50	40	35
Latão	730	560	400	330	270	240	210	190	170	150	130	120	110	100	85	75
Alumínio / Liga lig.	825	635	450	375	305	270	240	220	195	170	150	135	120	105	85	75
Madeira	900	670	510	390	320	280	250	230	200	180	160	140	130	120	100	95
Plástico	650	500	350	300	250	220	200	170	150	130	120	100	90	80	70	65
Gesso	900	670	510	390	320	250	230	200	180	160	140	130	120	100	95	80
HSS-CO + 20% com refrigeração																

Fresas para martelo com dentes em metal duro



Material a trabalhar	R. P. M. 25 a 45	R. P. M. 45 a 65	R. P. M. 70 a 100	R. P. M. 110 a 130
Concreto / Parede	1,000	900	750	550
Cimento armado	800	700	600	400

Brocas escalonadas HSS



Material a trabalhar		R. P. M.													
		1	2	3	4	5	6	7	8	9	10	21	22	23	24
Aço inox	3 a 4 mm	600	600	400	400	280	280	200	160	220	160	340	280	220	220
Aço de construção	3 a 4 mm	950	950	720	720	420	420	340	300	370	280	600	420	370	370
Aço de liga	3 a 4 mm	1450	1450	1100	1100	630	630	500	470	550	440	900	630	550	550
Plástico	3 a 4 mm	900	900	700	700	400	400	320	300	350	270	550	400	350	350
HSS - TiN + 30% com refrigeração										HSS + TiAlN + 50% a 80% a seco					

Fresas perfuradoras HSS rectificadas



Material a trabalhar		R. P. M.											
		12 a 17	18 a 24	25 a 32	33 a 38	39 a 44	46 a 51	52 a 57	58 a 64	65 a 70	71 a 80	81 a 90	91 a 100
Aço inox		400	350	280	230	200	180	150	120	100	80	70	60
Aço de construção		300	240	200	160	140	110	90	80	70	60	50	50
Aço de liga		360	270	230	180	170	150	120	90	80	70	60	50
Plástico		1000	900	700	600	550	500	450	420	380	350	320	300
HSS - TiN + 30% com refrigeração										HSS + TiAlN + 50% a 80% a seco			

Fresas perfuradoras TCT com plaketes em metal duro



Material a trabalhar	R. P. M.							
	15 a 20	21 a 25	25 a 30	31 a 40	41 a 50	51 a 70	70 a 100	
Aço de liga	800	600	500	450	380	280	100	
Aço inox	520	400	330	280	250	180	150	
Cobre	1300	1100	950	700	550	380	280	

Fresas rotativas em HSS



Ø mm	Velocidade de corte mt. / min.							
	80	100	150	200	220	230	240	250
6	4250	5310	7960	10620	11680	12210	12740	13270
8	3180	3980	5970	7960	8760	9160	9550	9950
10	2550	3180	4780	6370	7010	7320	7640	7960
12	2120	2650	3980	5310	5840	6100	6370	6630
15	1700	2120	3180	4250	4670	4880	5100	5310

Fresas rotativas em metal duro



Ø mm	Velocidade de corte mt. / min.					
	300	320	340	360	380	400
6	15930	16980	18050	19100	20170	21230
8	11950	12740	13535	14330	15130	15920
10	9550	10190	10830	11465	12100	12740
12	7960	8490	9020	9560	10085	10620
16	5970	6370	6770	7160	7570	7960

Fresas para máquinas com base electromagnética em HSS



Ø mm	Aço 700 N/mm	Aço inox 1000 N/mm	Ferro fundido	Alumínio
12 - 14	730	500	265	730
15 - 17	600	400	215	600
18 - 20	500	335	168	500
21 - 23	430	290	150	430
24 - 26	380	255	130	380
27 - 30	330	220	115	330
31 - 34	290	195	100	290
35 - 40	245	165	85	245
41 - 45	225	146	72	225
46 - 50	195	127	64	195
51 - 55	175	115		175
56 - 60	158	107		158
61 - 65	142	100		142
66 - 70	136	91		136
75 - 80	120	80		120
85 - 90	110	85		110
95 - 100	95	65		95

HSS-CO + 20% com refrigeração

Fresas para máquinas com base electromagnética em TCT



Ø mm	Aço 700 N/mm	Aço inox 1000 N/mm	Fundição
15 - 20	800	520	670
21 - 25	600	400	500
26 - 30	500	330	425
31 - 40	450	280	320
41 - 50	380	250	270
51 - 70	280	180	200
70 - 100	200	130	150
105 - 120	120	90	100



Serras circulares HSS

Material a trabalhar	Ø 200	Ø 225	Ø 250	Ø 275	R. P. M. Ø 300	Ø 315	Ø 350	Ø 370	Ø 400
Aço de 50 Kg mm	64	56	50	46	42	40	36	34	32
Aço de 75 Kg mm	48	42	38	34	32	30	28	26	24
Aço de 100 Kg mm	32	28	25	23	21	20	18	17	16
Tubo aço / perfis	80	71	64	58	53	51	45	43	40
Fundição	64	56	50	46	42	40	36	34	32
Aço inoxidável	24	21	19	17	16	15	14	13	12
Cobre / Bronze	318	283	255	231	12	202	182	172	159
Latão	637	566	509	463	424	404	364	344	318
Perfis e ligações lig.	2069	1839	1655	1504	1379	1313	1182	1118	1034
Ebonite (borracha)	95	85	76	69	64	61	55	52	48
P. V. C. e similares	207	184	166	150	138	131	118	112	103

Serras circulares com dentes em metal duro para alumínio e madeira

Ø mm	R. P. M. MAX.
200	10,000
250	8,000
300	6,000
350	6,000
400	4,500
450	4,000
500	3,500
550	3,000
600	2,800



Serras circulares com dentes em metal duro para alumínio, madeira e seus derivados

Material a trabalhar	m / seg
Madeira mole	60 : 90
Madeira dura	50 : 70
Contraplacado	60 : 80
Plástico	25 : 60
Alumínio	20 : 30



$$R. P. M. = \frac{V / C \times 1000}{\pi \times \phi}$$



Rosca métrica fina - MF

Ø x Passo mm	Ø Broca mm	Ø x Passo mm	Ø Broca mm
2,50 x 0,35	2,20	24,00 x 1,50	22,50
3,00 x 0,35	2,60	24,00 x 2,00	22,00
3,50 x 0,35	3,10	25,00 x 1,00	24,00
4,00 x 0,50	3,50	25,00 x 1,50	23,50
4,50 x 0,50	4,00	25,00 x 2,00	23,00
5,00 x 0,50	4,50	27,00 x 1,00	26,00
5,50 x 0,50	5,00	27,00 x 1,50	25,50
6,00 x 0,75	5,20	27,00 x 2,00	25,00
7,00 x 0,75	6,20	28,00 x 1,00	27,00
8,00 x 0,75	7,20	28,00 x 1,50	26,50
8,00 x 1,00	7,00	28,00 x 2,00	26,00
9,00 x 0,75	8,20	30,00 x 1,00	29,00
9,00 x 1,00	8,00	30,00 x 1,50	28,50
10,00 x 0,75	9,20	30,00 x 2,00	28,00
10,00 x 1,00	9,00	30,00 x 3,00	27,00
10,00 x 1,25	8,80	32,00 x 1,50	30,50
11,00 x 0,75	10,20	32,00 x 2,00	30,00
11,00 x 1,00	10,00	33,00 x 1,50	31,50
12,00 x 1,00	11,00	33,00 x 2,00	31,00
12,00 x 1,25	10,80	33,00 x 3,00	30,00
12,00 x 1,50	10,50	35,00 x 1,50	33,50
14,00 x 1,00	13,00	36,00 x 1,50	34,50
14,00 x 1,25	12,80	36,00 x 2,00	34,00
14,00 x 1,50	12,50	36,00 x 3,00	33,00
15,00 x 1,00	14,00	39,00 x 1,50	37,50
15,00 x 1,50	13,50	39,00 x 2,00	37,00
16,00 x 1,00	15,00	39,00 x 3,00	36,00
16,00 x 1,50	14,50	40,00 x 1,50	38,50
17,00 x 1,00	16,00	40,00 x 2,00	38,00
17,00 x 1,50	15,50	40,00 x 3,00	37,00
18,00 x 1,00	17,00	42,00 x 1,50	40,50
18,00 x 1,50	16,50	42,00 x 2,00	40,00
18,00 x 2,00	16,00	42,00 x 3,00	39,00
20,00 x 1,00	19,00	45,00 x 1,40	43,50
20,00 x 1,50	18,50	45,00 x 2,00	43,00
20,00 x 2,00	18,00	45,00 x 3,00	42,00
22,00 x 1,00	21,00	48,00 x 1,50	46,50
22,00 x 1,50	20,50	48,00 x 2,00	46,00
22,00 x 2,00	20,00	48,00 x 3,00	45,00
24,00 x 1,00	23,00	50,00 x 1,50	48,50

Rosca métrica - M

Ø x Passo mm	Ø Broca mm
2,00 x 0,40	1,60
2,50 x 0,45	2,05
3,00 x 0,50	2,50
3,50 x 0,60	2,90
4,00 x 0,70	3,30
4,50 x 0,75	3,80
5,00 x 0,80	4,20
6,00 x 1,00	5,00
7,00 x 1,00	6,00
8,00 x 1,25	6,80
9,00 x 1,25	7,80
10,00 x 1,50	8,50
11,00 x 1,50	9,50
12,00 x 1,75	10,20
14,00 x 2,00	12,00
16,00 x 2,00	14,00
18,00 x 2,50	15,50
20,00 x 2,50	17,50
22,00 x 2,50	19,50
24,00 x 3,00	21,00
27,00 x 3,00	24,00
30,00 x 3,50	26,50
33,00 x 3,50	29,50
36,00 x 4,00	32,00
39,00 x 4,00	35,00
42,00 x 4,50	37,50

Rosca BSPT "Gás Cônica"

Ø x Passo f/1" polegadas	Min T1 mm	D1 mm	D2 mm	D3 mm
1/8 x 28	12,00	7,70	7,50	8,57
1/4 x 19	16,50	11,00	10,80	11,44
3/8 x 19	17,50	14,60	14,30	14,95
1/2 x 14	21,50	18,20	17,80	18,63
5/8 x 14	21,50	20,20	19,80	20,59
3/4 x 14	24,00	23,40	22,90	24,12
7/8 x 14	25,50	30,10	26,60	27,87
1" x 11	27,00	30,40	29,10	30,29

Rosca BSF

Ø x Passo f/1" polegadas	Ø Broca mm
3/16 x 32	4,00
7/32 x 28	4,70
1/4 x 26	5,40
9/32 x 26	6,20
5/16 x 22	6,80
3/8 x 20	8,30
7/16 x 18	9,80
1/2 x 16	11,20
9/16 x 16	12,70
5/8 x 14	14,00
11/16 x 14	15,70
3/4 x 12	17,00
13/16 x 12	18,50
7/8 x 11	20,00
1" x 10	23,00
1"1/8 x 9	26,00
1"1/4 x 9	29,00
1"3/8 x 8	32,00
1"1/2 x 8	35,00
1"5/8 x 8	38,00
1"3/4 x 7	40,50
2" x 7	47,00
2"1/4 x 6	52,50
2"1/2 x 6	59,00

Rosca BSP "Gás"

Ø x Passo f/1" polegadas	Ø Broca mm
1/8 x 28	8,80
1/4 x 19	11,80
3/8 x 19	15,25
1/2 x 14	19,00
5/8 x 14	21,60
3/4 x 14	24,50
7/8 x 14	28,25
1" x 11	30,75
1"1/8 x 11	35,50
1"1/4 x 11	39,50
1"3/8 x 11	42,00
1"1/2 x 11	45,50
1"5/8 x 11	49,60
1"3/4 x 11	51,40
2" x 11	57,20
2"1/4 x 11	63,30
2"3/8 x 11	67,00
2"1/2 x 11	72,80
2"3/4 x 11	79,10
3" x 11	85,50
3"1/4 x 11	91,50
3"1/2 x 11	98,00
3"3/4 x 11	104,00
4" x 11	110,50

Rosca UNC

Ø x Passo f/1" polegadas	Ø Broca mm
Nr 1 x 64	1,50
Nr 2 x 56	1,80
Nr 3 x 48	2,10
Nr 4 x 40	2,30
Nr 5 x 40	2,60
Nr 6 x 32	2,80
Nr 7 x 32	3,50
Nr 10 x 24	3,90
Nr 12 x 24	4,50
1/4 x 20	5,20
5/16 x 18	6,60
3/8 x 16	8,00
7/16 x 14	9,40
1/2 x 13	10,75
9/16 x 12	12,25
5/8 x 11	13,50
3/4 x 10	16,50
7/8 x 9	19,50
1" x 8	22,25
1"1/8 x 7	25,00
1"1/4 x 7	28,25
1"3/8 x 6	30,75
1"1/2 x 6	34,00
1"3/4 x 5	39,50
2" x 4"1/2	45,25
2"1/4 x 4"1/2	51,50
2"1/2 x 4"1/2	57,25

Rosca BSW "Whitworth"

Ø x Passo f/1" polegadas	Ø Broca mm
1/8 x 40	2,60
5/32 x 32	3,10
3/16 x 24	3,60
7/32 x 24	4,40
1/4 x 20	5,10
5/16 x 18	6,50
3/8 x 16	7,90
7/16 x 14	9,30
1/2 x 12	10,50
9/16 x 12	12,00
5/8 x 11	13,50
3/4 x 10	16,50
7/8 x 9	19,25
1" x 8	22,00
1"1/8 x 7	24,75
1"1/4 x 7	27,75
1"3/8 x 6	30,50
1"1/2 x 6	33,50
1"5/8 x 5	35,50
1"3/4 x 5	39,00
1"7/8 x 4,5	41,50
2" x 4,5	44,50
2"1/4 x 4	50,00
2"1/2 x 4	56,50

Rosca NPT



Ø x Passo f/1" polegadas	Min T1 mm	D1 mm	D2 mm	D3 mm
1/16 x 27	12,00	6,20	6,00	6,39
1/8 x 27	12,00	8,50	8,30	8,74
1/4 x 18	17,50	11,00	10,70	11,36
3/8 x 18	17,60	14,50	14,20	14,80
1/2 x 14	22,90	17,80	17,40	18,32
3/4 x 14	23,00	23,00	22,50	23,67
1" x 11,5	27,40	29,00	28,50	29,69
1"1/4 x 11,5	28,00	28,00	37,50	38,45
1"1/2 x 11,5	28,40	28,40	44,00	44,52
2" x 11,5	28,00	28,00	56,00	56,56
2"1/2 x 8	40,80	66,50	66,00	67,62
3" x 8	43,00	43,00	82,50	83,53
3"1/2 x 8	44,50	44,50	95,00	96,24
4" x 8	45,50	107,70	107,20	108,89



Rosca métrica e métrica fina

∅ Rosca mm	∅ Broca mm
M 2 x 0,40	2,10
M 2,2 x 0,45	2,30
M 2,5 x 0,45	2,60
M 3 x 0,50	3,20
M 3,5 x 0,60	3,70
M 4 x 0,70	4,20
M 5 x 0,80	5,20
M 6 x 1,00	6,30
M 7 x 1,00	7,30
M 8 x 1,25	8,30
M 8 x 1,00	8,30
M 9 x 1,25	9,30
M 10 x 1,50	10,40
M 10 x 1,25	10,30
M 10 x 1,00	10,30
M 11 x 1,50	11,40
M 12 x 1,75	12,40
M 12 x 1,50	12,40
M 12 x 1,25	12,30
M 12 x 1,00	12,30
M 14 x 2,00	14,50
M 14 x 1,50	14,40
M 14 x 1,25	14,40
M 14 x 1,00	14,30
M 16 x 2,00	16,50
M 16 x 1,50	16,40
M 18 x 2,50	18,60
M 18 x 2,00	18,50
M 18 x 1,50	18,50
M 20 x 2,50	20,60
M 20 x 2,00	20,50
M 20 x 1,50	20,50
M 22 x 2,50	22,60
M 22 x 2,00	22,50
M 22 x 1,50	22,50
M 24 x 3,00	24,75
M 24 x 2,00	24,50
M 24 x 1,50	24,50
M 26 x 1,50	26,50
M 27 x 3,00	27,75
M 27 x 2,00	27,50
M 27 x 1,50	27,50
M 28 x 1,50	28,50
M 30 x 3,50	31,00
M 30 x 2,00	30,50
M 30 x 1,50	30,50
M 33 x 3,50	34,00
M 33 x 2,00	33,50
M 36 x 4,00	37,00
M 36 x 3,00	37,00
M 36 x 2,00	36,50
M 36 x 1,50	36,50



Rosca UNF

∅ Rosca mm	∅ Broca mm
8 x 36	4,40
10 x 32	5,10
1/4 x 28	6,60
5/16 x 24	8,20
3/8 x 24	9,80
7/16 x 20	11,50
1/2 x 20	13,00
9/16 x 18	14,80
5/8 x 18	16,25
3/4 x 16	19,50
7/8 x 14	22,75
1" x 12	26,00
1"1/8 x 12	29,00
1"1/4 x 12	32,50
1"1/2 x 12	38,50

Rosca BSF

∅ Rosca mm	∅ Broca mm
3/16 x 32	5,00
1/4 x 26	6,60
5/16 x 22	8,30
3/8 x 20	9,90
7/16 x 18	11,60
1/2 x 16	13,00
9/16 x 16	14,80
5/8 x 14	16,40
3/4 x 12	19,50
7/8 x 11	22,70
1" x 10	26,50

Rosca BSP

Ø Rosca mm	Ø Broca mm
1/8 x 28	10,00
1/4 x 19	13,60
3/8 x 19	17,10
1/2 x 14	21,50
5/8 x 14	23,40
3/4 x 14	27,00
7/8 x 14	30,60
1" x 11	33,70



Rosca UNC

Ø Rosca mm	Ø Broca mm
8 x 32	4,40
10 x 24	5,10
12 x 24	5,70
1/4 x 20	6,70
5/16 x 18	8,30
3/8 x 16	9,90
7/16 x 14	11,60
1/2 x 13	13,00
9/16 x 12	14,80
5/8 x 11	16,50
3/4 x 10	19,75
7/8 x 9	23,00
1" x 8	26,25
1"1/8 x 7	29,50
1"1/4 x 7	33,00
1"1/2 x 6	39,50

Rosca BSW

Ø Rosca mm	Ø Broca mm
1/8 x 40	3,40
3/16 x 24	5,10
1/4 x 20	6,70
5/16 x 18	8,30
3/8 x 16	9,90
7/16 x 14	11,60
1/2 x 12	13,00
9/16 x 12	14,80
5/8 x 11	16,70
3/4 x 10	20,00
7/8 x 9	23,00
1" x 8	26,50